

KUARK
YAYINLARI

YÖS
DENEME
SINAVLARI

TRIAL
EXAMS

yös

Yabancı Öğrenci Sınavları

● YÖS EĞİTİM TURİZM TİC. LTD. ŞTİ.

- **Adres:** Yüce-tepe Mah. 91. Cad. No: 10/8 Çankaya Ankara - Türkiye
Tel: 0312 229 39 67 **Mobil:** 0545 659 15 45
- **Web:** www.kuarkyayinlari.com
Email: info@kuarkyayinlari.com
- **Grafik ve Kapak Tasarımı:** Kuark Yayınları Grafik Tasarım Departmanı
- **Yayıncı Sertifika No:** 42944
Matbaa Sertifika No: 13268
- **ISBN:** 978-605-80904-2-2
- **Baskı Tarihi:** Mart 2019

Bu eserin her hakkı saklı olup tüm hakları YÖS Eğitim Turizm Ticaret Limited Şirketi'ne aittir. Kısmen de olsa alıntı yapılamaz, metin ve soruları aynen veya değiştirilerek elektronik, mekanik, fotokopi ya da başka türlü bir sistemle çoğaltılamaz, depolanamaz.

ÖNSÖZ

Değerli öğrencilerimiz,

KUARK Yayınları Türkiye'deki üniversitelerde öğrenim görmek isteyen yabancı uyruklu öğrencilere en güncel ve nitelikli yayınları sunmak için yayın hayatına başlamış olan bir yayınevdir. Yayınevimiz Yabancı Uyruklu Öğrenci Sınavlarına (YÖS) hazırlanan öğrencilere tamamı güncel sorulardan oluşan hazırlık kitapları sunarak, öğrencilerin hedeflerine ulaşmalarını sağlamak için yola çıkmıştır.

KUARK Yayınları'nın dinamik kadrosu en kapsamlı araştırmaları ve ayrıntılı sınav incelemelerini gerçekleştirerek yabancı uyruklu öğrencilere üniversite kapılarını aralayacak Matematik, Geometri, Genel Yetenek (IQ) ve Deneme Sınavları kitaplarını hazırlamıştır.

KUARK Yayınları olarak çıktığımız bu yolda hiç durmadan çalışarak, yeni yayınlarımızla beraber eğitim-öğretim ve danışmanlık hizmetlerimizle yabancı uyruklu öğrencilere kılavuz olacağız.
Yabancı Uyruklu Öğrenci Sınavlarına katılacak olan tüm adaylara başarılar dileriz.

PREFACE

Dear students,

KUARK Publications is a publishing house that has started to publish the most up-to-date and qualified books for the foreign students who want to pursue their higher education in Turkey.

KUARK Publications aims to help the students who are preparing for university entrance Examinations for Foreign Students which means YÖS to reach their goals and to eliminate challenges with its preparatory books containing completely up-to-date questions.

KUARK Publications dynamic staff did a through and broad research and detailed examination reviews to make the most comprehensive source for the students who will take the exam and to open the doors of the university for them by publishing Mathematics, Geometry, Intelligence Quotient (IQ) and YÖS Trial Exam books.

As KUARK Publications, we will constantly move forward in this new path without stopping and improve with each passing day and be continuously updated to guide our foreign students with our publications, education-training and guidance services.

We wish success to all candidates who will take the Foreign Student Exams.

İÇİNDEKİLER / CONTENTS

DENEME SINAVI 1 - TRIAL EXAM 1

Deneme Sınavı 1	
Trial Exam 1	1 - 20

DENEME SINAVI 2 - TRIAL EXAM 2

Deneme Sınavı 2	
Trial Exam 2	21 - 40

DENEME SINAVI 3 - TRIAL EXAM 3

Deneme Sınavı 3	
Trial Exam 3	41 - 60

DENEME SINAVI 4 - TRIAL EXAM 4

Deneme Sınavı 4	
Trial Exam 4	61 - 80

İÇİNDEKİLER / CONTENTS

DENEME SINAVI 5 - TRIAL EXAM 5

Deneme Sınavı 5

Trial Exam 5 81 - 100

DENEME SINAVI 6 - TRIAL EXAM 6

Deneme Sınavı 6

Trial Exam 6 101 - 120

DENEME SINAVI 7 - TRIAL EXAM 7

Deneme Sınavı 7

Trial Exam 7 121 - 140

DENEME SINAVI 8 - TRIAL EXAM 8

Deneme Sınavı 8

Trial Exam 8 141 - 160

İÇİNDEKİLER / CONTENTS

DENEME SINAVI 9 - TRIAL EXAM 9

Deneme Sınavı 9	
Trial Exam 9	161 - 180

DENEME SINAVI 10 - TRIAL EXAM 10

Deneme Sınavı 10	
Trial Exam 10	181 - 200

DENEME SINAVI 11 - TRIAL EXAM 11

Deneme Sınavı 11	
Trial Exam 11	201 - 220

DENEME SINAVI 12 - TRIAL EXAM 12

Deneme Sınavı 12	
Trial Exam 12	221 - 240

İÇİNDEKİLER / CONTENTS

DENEME SINAVI 13 - TRIAL EXAM 13

Deneme Sınavı 13

Trial Exam 13..... 241 - 260

DENEME SINAVI 14 - TRIAL EXAM 14

Deneme Sınavı 14

Trial Exam 14..... 261 - 284

DENEME SINAVI 15 - TRIAL EXAM 15

Deneme Sınavı 15

Trial Exam 15..... 285 - 308

1, 2, 3 ve 4. sorularda verilen işlemlerde her harf sıfırdan ve birbirinden farklı birer rakamı göstermektedir. Buna göre, soru işareti ile belirtilen harf ya da işlemin değerini bulunuz.

In the operations which are given in questions 1, 2, 3 and 4 each letter stands for a different numeral non-zero. Accordingly, find the value of the letter or operation indicated by the question mark.

$$1. \begin{array}{r} KLM \\ - MLK \\ \hline RT3 \end{array} + \begin{array}{r} T \\ R \\ \hline 1N \end{array} \Rightarrow N = ?$$

- A) 5 B) 6 C) 7 D) 8 E) 9

$$2. \begin{array}{r} HY \\ - YH \\ \hline T \end{array} \Rightarrow \max(HY) = ?$$

- A) 98 B) 87 C) 76 D) 54 E) 45

$$3. \begin{array}{r} ABE \\ + CDF \\ \hline 888 \end{array} \Rightarrow \frac{A+F+E+C}{B+D} = ?$$

- A) 1 B) 2 C) 3 D) 4 E) 5

$$4. \begin{array}{r} KL \\ LK \\ + KK \\ \hline 1KL \end{array} \Rightarrow L = ?$$

- A) 4 B) 5 C) 6 D) 7 E) 8

5, 6, 7 ve 8. sorularda I. gruptaki her bir harf, rakam veya şekil, II. gruptaki farklı birer harf, rakam veya şekil ile gösterilmiştir. Buna göre, soru işaretiyle belirtilen harfleri, rakamları veya şekilleri bulunuz.

In questions 5, 6, 7 and 8 each letter, numeral or figure in group I stand for a different letter, numeral or figure in group II. Accordingly, find the letters, numerals or figures which the questions mark stands for.

$$5. \begin{array}{l} \text{I.} \\ \text{MUM} \\ \text{ZAM} \\ \text{AZA} \\ \text{MAT} \\ \text{TAT} \end{array} \left. \begin{array}{l} \\ \\ \\ \\ \\ \end{array} \right\} \begin{array}{l} \text{II.} \\ 123 \\ 212 \\ 343 \\ 525 \\ 325 \end{array} \Rightarrow \text{TAT} = ?$$

- A) 123 B) 212 C) 343 D) 525 E) 325

YÖS

1

6.

I.	II.
1 2 3 2 4	SEPET
5 6 7 2 4	VELET
8 2 7 2 4	KERAT
0 2 9 6 4	NALET
4 2 7 8 2	TELVE

⇒ 82724 = ?

- A) SEPET B) VELET C) KERAT
D) NALET E) TELVE

8.

I.	II.
U S K U R	IKSIT
S A K A R	SIKIT
K U S U R	KOSOT
A K S A R	OSKOT
B A K A R	YIKIT

⇒ KUSUR = ?

- A) IKSIT B) SIKIT C) KOSOT
D) OSKOT E) YIKIT

K U A R K Y A Y I N L A R I

7.

I.	II.
T A Z I	3 5 3 5
A T K I	2 4 3 5
Z A M K	9 2 9 2
Y A Y A	4 2 7 5
K I K I	7 2 6 3

⇒ ATKI = ?

- A) 3535 B) 2435 C) 9292
D) 4275 E) 7263

9.

+	a	b	c
a		c+5	
b			4a
c	2b		

⇒ a = ?

Yukarıdaki toplama tablosunda a, b ve c harfleri pozitif birer tam sayının yerine kullanılmıştır. Buna göre, a kaçtır?

In the summation table above, the letters a, b and c each stand for a positive integer. Accordingly, what is the value of a?

- A) 15 B) 25 C) 35 D) 45 E) 55

K U A R K P U B L I C A T I O N S

YÖS

1

10.

+	a	b	c
a			
b			35
c			

x	a	b	c
a		75	
b			
c	100		

$$\Rightarrow a = ?$$

Yukarıdaki toplama ve çarpma tablolarında a, b ve c harfleri pozitif birer tam sayının yerine kullanılmıştır. Buna göre, a kaçtır?

In the summation and multiplication tables above, the letters a, b and c each stand for a positive integer.

Accordingly, what is the value of a?

- A) 5 B) 6 C) 7 D) 8 E) 9

11.

+	a	b	c
a		6ab	
b			3bc
c			

$$\Rightarrow \frac{1}{a} - \frac{1}{c} = ?$$

Yukarıdaki toplama tablosunda a, b ve c harfleri pozitif birer sayının yerine kullanılmıştır. Buna göre, $\frac{1}{a} - \frac{1}{c}$ kaçtır?

In the multiplication table above, the letters a, b and c each stand for a positive number. Accordingly, what is the value of $\frac{1}{a} - \frac{1}{c}$?

- A) -3 B) -1 C) 1 D) 3 E) 5

12.

				Sonuç (Result)
8	6	9	9	4
2	5	7	6	10
4	12	6	2	6
5	8	4	13	6
3	7	12	2	?

Yukarıda verilen tabloda soru işaretinin yerine, aşağıdaki sayılardan hangisi gelmelidir?

Which of the following numbers does the question mark stand for in the table above?

- A) 6 B) 7 C) 8 D) 9 E) 10

13.

□	a	b	c
a	x	y	z
b	k	x	s
c	z	k	m

●	x	y	z
x	a	b	c
y	b	d	e
z	c	e	f

$$\Rightarrow [((a \square c) \bullet (b \square b)) \square a] \bullet z = ?$$

Yukarıdaki tablolar □ ve ● işlemlerine göre düzenlenmiştir. Buna göre,

$$[((a \square c) \bullet (b \square b)) \square a] \bullet z = ?$$

The tables above are organized according to the □ and ● operations. Accordingly, what is the value of $[((a \square c) \bullet (b \square b)) \square a] \bullet z = ?$

- A) f B) c C) b D) e E) d

YÖS

1

14.

□	S	T	M	K	L
S	L	M	M	M	K
T	T	L	K	T	S
M	M	K	S	T	M
K	M	T	T	S	L
L	K	S	M	L	T

$$((M \square x) \square (L \square S)) \square S = L$$

$$\Rightarrow x = ?$$

Yukarıdaki tablo □ işlemine göre düzenlenmiştir. Buna göre, x nedir?

The table above is organized according to the □ operation. Accordingly, what is the value of x?

- A) S B) T C) M D) K E) L

15.

	▲●□	□○▲	△■○
△○	—	○	△○
■▲	▲	?	■
●□	●□	□	—

Yukarıdaki tabloya göre soru işaretinin yerine hangi şekiller gelmelidir?

According to the table above, which of the figures does the question mark stand for?

- A) □ B) ● C) △ D) ▲ E) ○

16. I. $42 \blacktriangle 64 = 8$
 II. $86 \blacktriangle 22 = 9$
 III. $44 \blacktriangle 24 = 7$
 IV. $28 \blacktriangle 66 = ?$

Yukarıdaki eşitliklerde ▲ işaretinin görevi verilmiştir. Buna göre, dördüncü eşitlikteki soru işaretinin yerine aşağıdaki sayılardan hangisi gelmelidir?

In the equations above, the function of ▲ is given. Accordingly, which of the following numbers does the question mark stand for in the fourth equation?

- A) 9 B) 10 C) 11 D) 12 E) 13

17. I. $\frac{1}{2} \Delta \frac{3}{2} = \frac{1}{3}$
 II. $\frac{2}{3} \Delta \frac{3}{2} = \frac{4}{9}$
 III. $\frac{1}{2} \Delta \frac{1}{3} = \frac{3}{2}$
 IV. $\frac{a}{b} \Delta \frac{d}{c} = ?$

Yukarıdaki eşitliklerde Δ işaretinin görevi verilmiştir. Buna göre, dördüncü eşitlikteki soru işaretinin yerine aşağıdakilerden hangisi gelmelidir?

In the equations above, the function of Δ is given. According to this function, what does the question mark stand for in the fourth equation?

- A) $\frac{a-d}{b-c}$ B) $\frac{a-c}{b-d}$ C) $\frac{a+d}{b+c}$
 D) $\frac{a+d}{b+d}$ E) $\frac{a-c}{b+d}$

K U A R K Y A Y I N L A R I

K U A R K P U B L I C A T I O N S

YÖS

1

18. I. $a \Delta b = 2 \cdot (a \Delta b) - 2$
 II. $a \blacktriangle b = \frac{a \blacktriangle b}{3} + 2$
 III. $(a \blacktriangle b) - (a \Delta b) = ?$

Yukarıdaki eşitliklerde Δ ve \blacktriangle işaretlerinin görevleri verilmiştir. Buna göre, üçüncü eşitlikteki soru işaretinin yerine aşağıdaki sayılardan hangisi gelmelidir?

In the equations above, the functions of Δ and \blacktriangle are given. Accordingly, which of the following numbers does the question mark stand for in the third equation?

- A) -2 B) 0 C) 1 D) 2 E) 4

20 ve 21. soruları aşağıdaki şekle göre cevaplayınız.
 Answer questions 13 and 14 in accordance with the figure given below.

Her soru birbirinden bağımsız olarak cevaplanacaktır.
 Each question is to be answered independently.

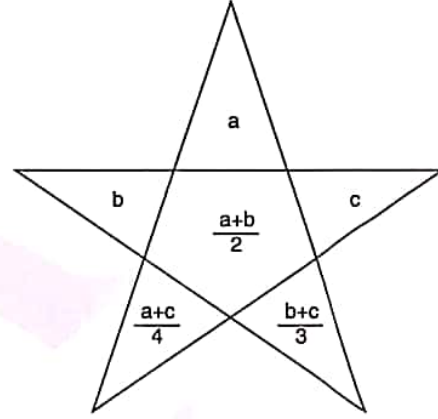

Yukarıdaki şekil a, b ve c harfleriyle gösterilen üç pozitif tamsayıyı içeren bazı işlemlere göre düzenlenmiştir. Harflerin gösterdiği sayılar her soruda farklı olabilir; fakat yapılacak işlemler her soruda aynıdır.

The figure above has been organized according to various operations using three positive integers represented by the letters a, b and c. The integers represented by the letters may change from question to question, but the operations to be done remain the same.

19. I. $a^2 \oplus b^3 = a \blacksquare b$
 II. $3 \cdot a \blacksquare 2 \cdot b = a + b - 2$
 III. $36 \oplus 64 = ?$

Yukarıdaki eşitliklerde \oplus ve \blacksquare işaretlerinin görevleri verilmiştir. Buna göre, üçüncü eşitlikteki soru işaretinin yerine aşağıdaki sayılardan hangisi gelmelidir?

In the equations above, the functions of \oplus and \blacksquare are given. Accordingly, which of the following numbers does the question mark stand for in the third equation?

- A) 2 B) 4 C) 8 D) 16 E) 32

K U A R K Y A Y I N L A R I

K U A R K P U B L I C A T I O N S

YÖS

1

20.

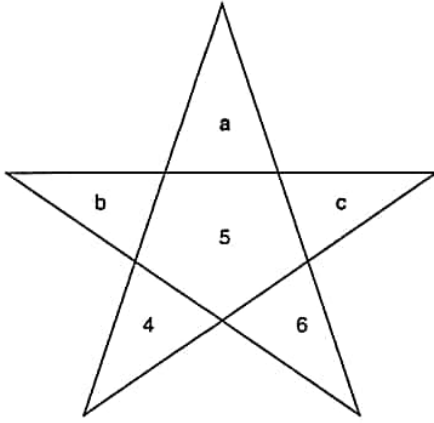

$$\Rightarrow a = ?$$

- A) 4 B) 6 C) 8 D) 10 E) 12

21.

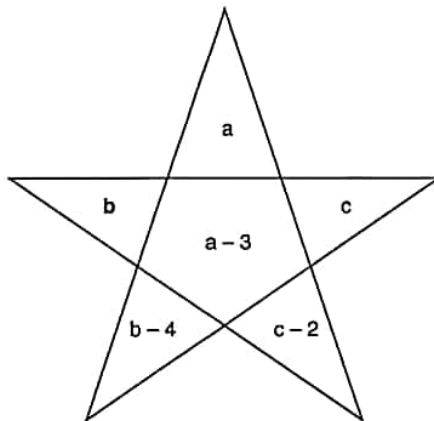

$$\Rightarrow b = ?$$

- A) 8 B) 10 C) 12 D) 14 E) 16

22.

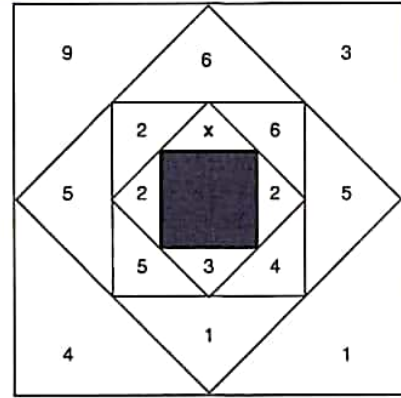

$$\Rightarrow x = ?$$

Yukarıdaki sayı-şekil ilişkisine göre x kaçtır?

According to the number-figure relation above, what is the value of x?

- A) 6 B) 7 C) 8 D) 9 E) 10

23.

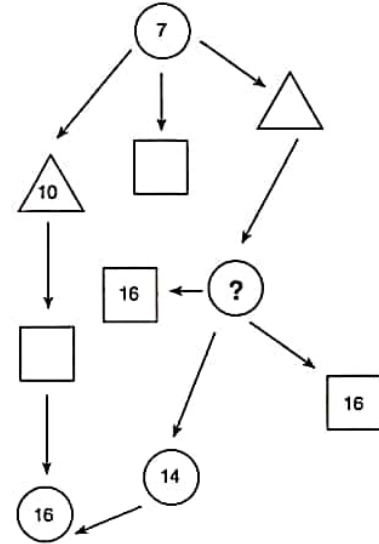

Yukarıdaki sayı-şekil dizisine göre soru işaretinin yerine aşağıdaki sayılardan hangisi gelmelidir?

Which of the following numbers does the question mark stand for, according to the number-figure sequence above?

- A) 10 B) 11 C) 12 D) 13 E) 14

K U A R K Y A Y I N L A R I

K U A R K P U B L I C A T I O N S

YÖS

1

24.

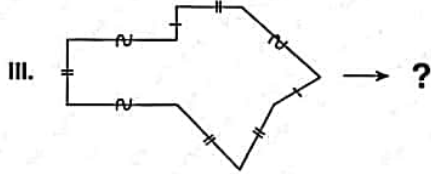
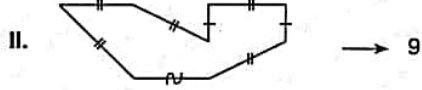
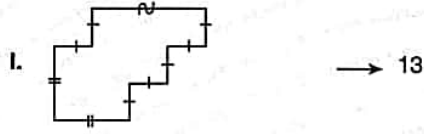

I. ve II. satırlarda belirlenen ilişkiye göre, III. satırı aşağıdaki sayılardan hangisi tamamlar?

Which of the following numbers completes III. in accordance with the relation established in I and II?

- A) 5 B) 6 C) 7 D) 8 E) 9

25.

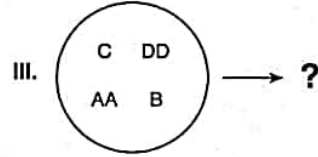
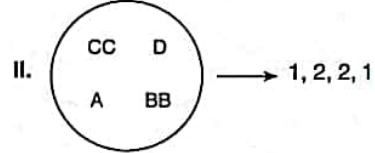
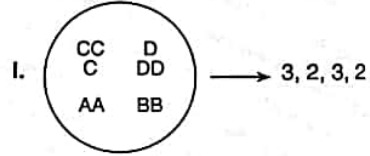

I. ve II. satırlarda belirlenen ilişkiye göre, III. satırı aşağıdaki sayılardan hangisi tamamlar?

Which of the following numbers completes III. in accordance with the relation established in I and II?

- A) 1, 2, 1, 1 B) 1, 2, 2, 1 C) 2, 1, 1, 2
D) 1, 2, 1, 2 E) 2, 1, 2, 1

K U A R K Y A Y I N L A R I

K U A R K P U B L I C A T I O N S

26 ve 27. sorularda farklı olan şekli bulunuz.

Find the different figure in questions 26 and 27.

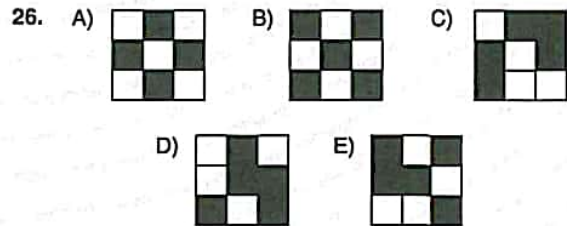

YÖS

1

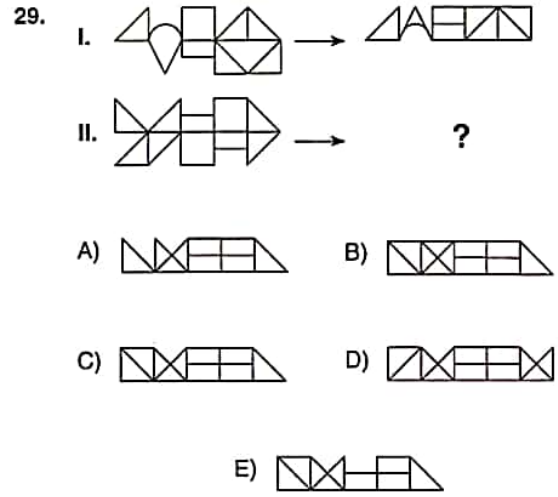
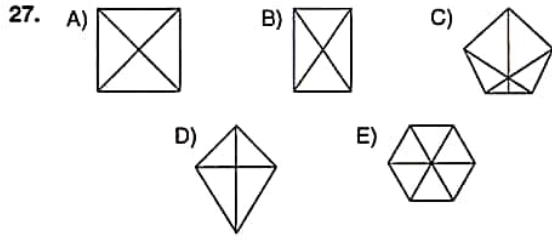

28 ve 29. sorularda, I. satırda belirlenen ilişkiye göre II. satırı hangi şeklin tamamladığını bulunuz.

In questions 28 and 29, find the figure which completes row II, in accordance with the relation established in row I.

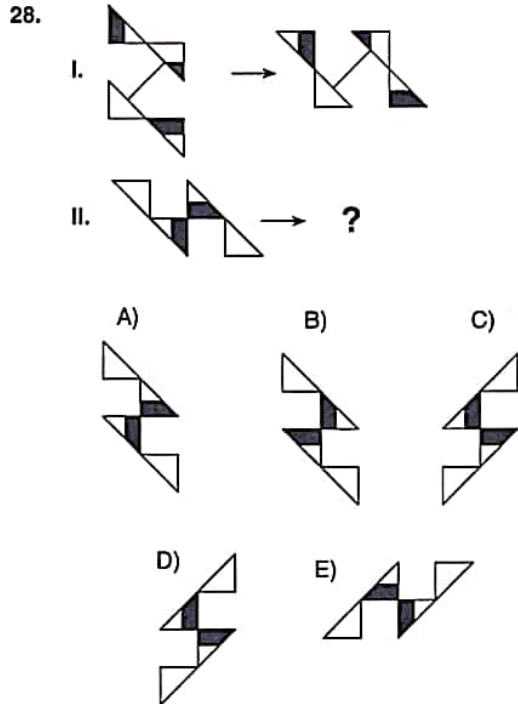

K U A R K Y A Y I N L A R I

K U A R K P U B L I C A T I O N S

YÖS

1

30.

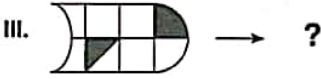
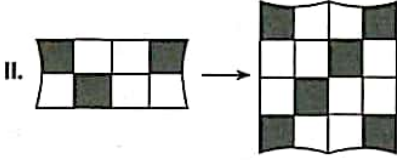
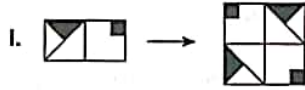

I. ve II. satırda belirlenen ilişkiye göre III. satırı hangi şeklin tamamladığını bulunuz.

Find the figure which completes row III, in accordance with the relation established in rows I and II.

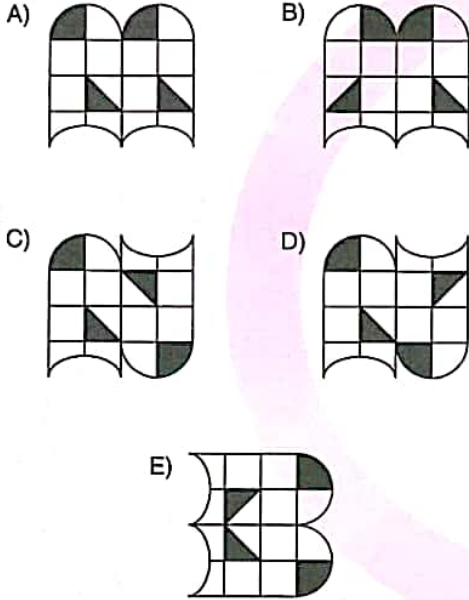

31 ve 32. soruları aşağıdaki örnekte verilen ilişkiye göre cevaplayınız.

Answer questions 31 and 32, in accordance with the relation established in the example below.

ÖRNEK / EXAMPLE:

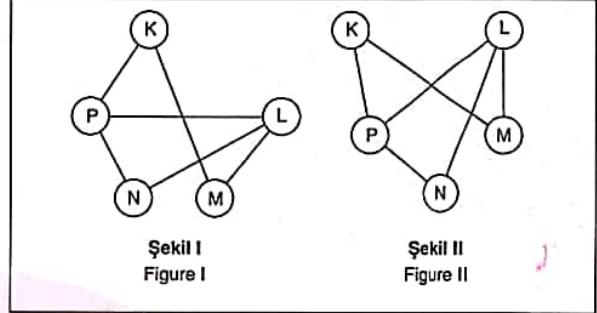

K, L, M, N ve P harfleri I. şekildeki gibi birbirine bağlanmıştır. I. şekildeki bağlantı sayıları ve birbirine bağlanan harfler değişmemek koşuluyla II. şekil elde edilmiştir.

The letters K, L, M, N and P are linked as in figure I. figure II as been constructed so as not to change the number of links and the letters that are linked to each other in figure I.

31.

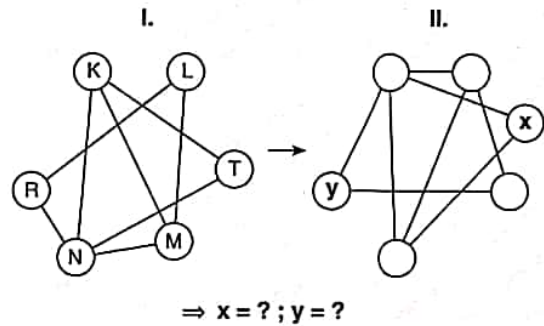

A) T; L B) R; T C) L; T D) L; R E) T; R

YÖS

1

32.

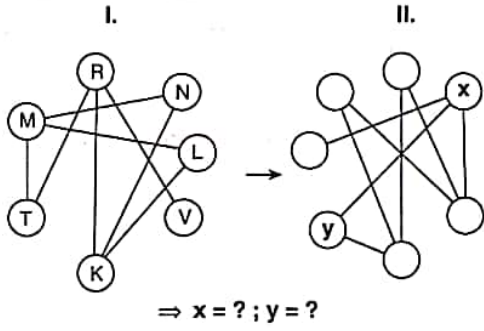





- A) K; N B) R; T C) M; T D) R; L E) K; L

33 ve 34. sorularda, verilen her bir şekil matrisindeki soru işaretinin yerine hangi şeklin getirilmesi gerektiğini bulunuz.

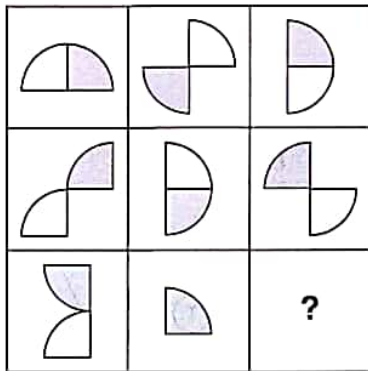
In questions 33 and 34, find the figure which should replace the question mark in each given figure matrix.

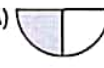
33.

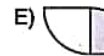

- A)  B)  C) 
- D)  E) 

34.

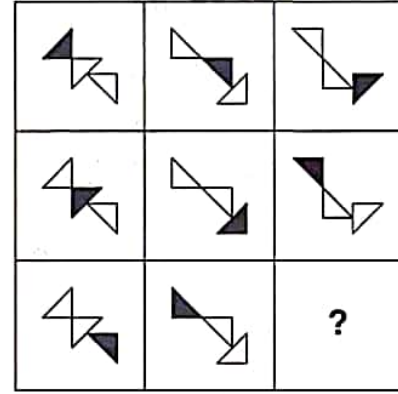

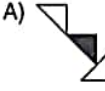
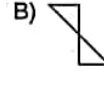
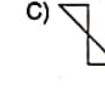
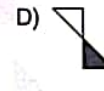
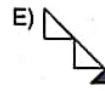
- A)  B)  C) 
- D)  E) 

35 ve 36. sorularda, soru işaretinin yerine getirilmesi gereken şekli bulunuz.

In question 35 and 36, find the figure to replace the question mark.

35.

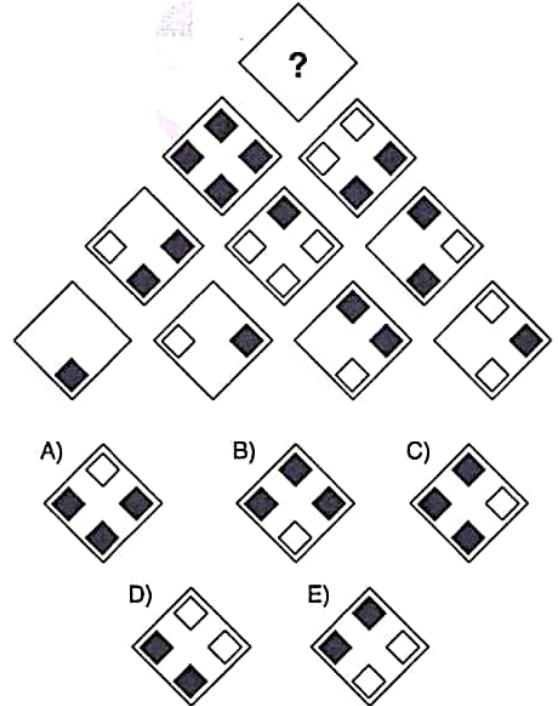

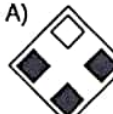
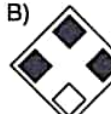
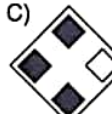
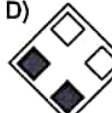
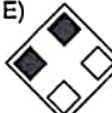
- A)  B)  C) 
- D)  E) 

YÖS

1

36.

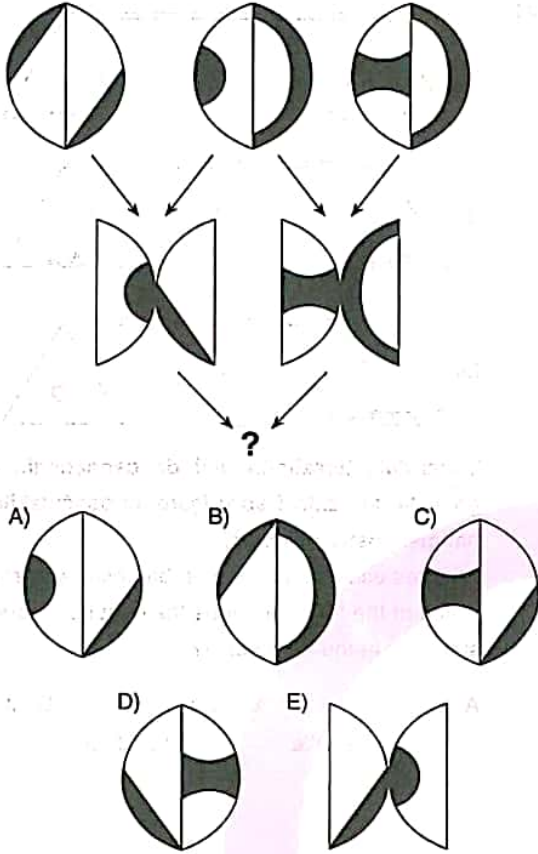

37.

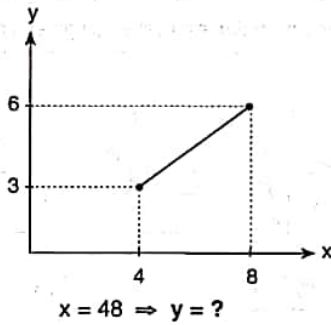

Yukarıdaki grafikte verilen bilgilere göre, y kaçtır?
According to the information given in the line chart above, what is the value of y ?

- A) 30 B) 33 C) 36 D) 39 E) 42

38.

	K	L	M	N
R	3	4	1	2
T	2	3	4	1
V	1	2	3	4
Z	4	1	2	3

I.

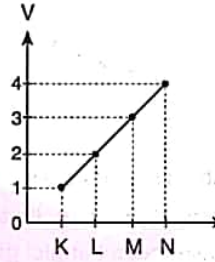

II.

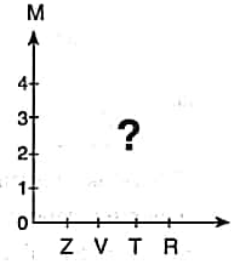

Yukarıda verilen I. ve II. grafikler tablodaki bilgilere göre düzenlenmiştir. Buna göre II. grafik aşağıdakilerden hangisidir?

Graphs I and II are organized according to the information given in the table above. Accordingly, which of the following stands for graph II?

A) M



B) M

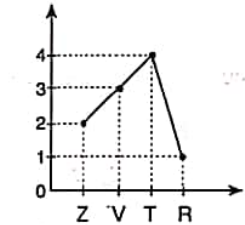

C) M



D) M

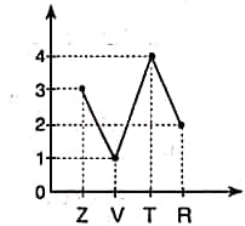

E) M

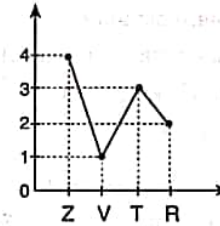

YÖS

1

39.

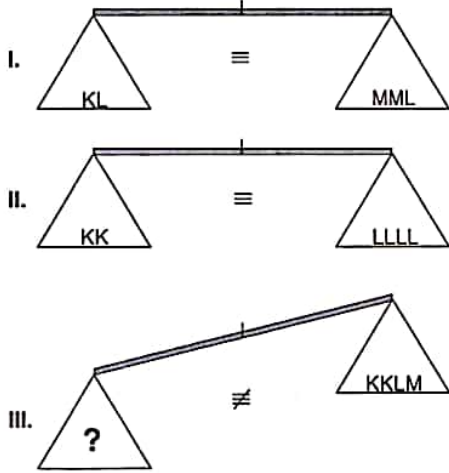

Yukarıdaki terazilerin ilk ikisi dengede olup, üçüncüsü dengede değildir. Buna göre, III. terazi-deki soru işaretini aşağıdakilerden hangisi göstermektedir?

First two scales above are in balance, the third scale is not in balance. Accordingly, which of the following does the question mark stand for in the third scale?

- A) MMK B) LL C) KKKL D) KLM E) L

40.

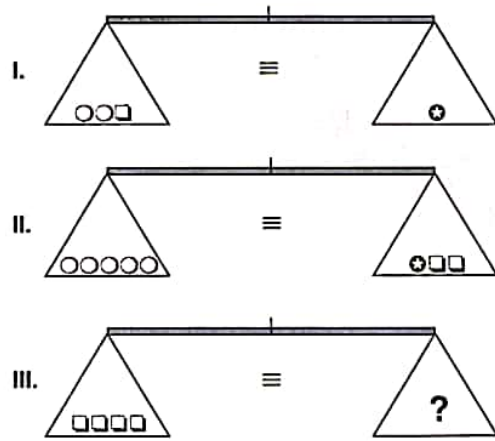

Yukarıdaki terazilerin üçü de dengededir. Buna göre, III. terazideki soru işaretini aşağıdakilerden hangisi göstermektedir?

All three scales above are in balance. Accordingly, which of the following does the question mark stand for in the third scale?

- A) ○ B) ○○ C) ○○○
D) ○○○○ E) ○○○○○

41.

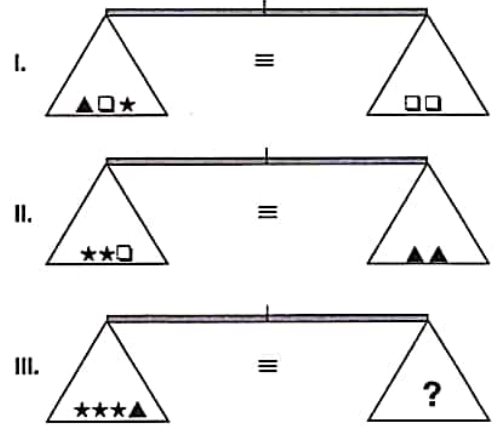

Yukarıdaki terazilerin üçü de dengededir. Buna göre, III. terazideki soru işaretini aşağıdakilerden hangisi göstermektedir?

All three scales above are in balance. Accordingly, which of the following does the question mark stand for in the third scale?

- A) □ B) ▲▲ C) □□
D) □▲ E) ▲▲□

42, 43 ve 44. sorularda, verilen her bir şekil dizisindeki soru işaretinin yerine hangi şeklin getirilmesi gerektiğini bulunuz.

In questions 42, 43 and 44, find the figure which should replace the question mark in each given figure sequence.

42.

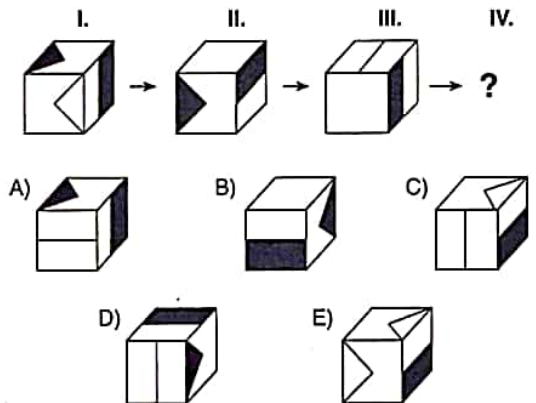

YÖS

1

43. I. II. III. IV.

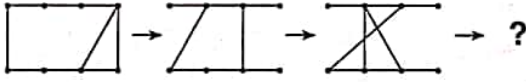

A)

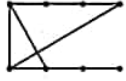

B)



C)

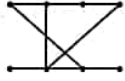

D)

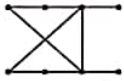

E)

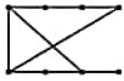

45. soruyu aşağıdaki örnekte verilen ilişkiye göre cevaplayınız.

Answer question 45, in accordance with the relation established in the example below.

ÖRNEK / EXAMPLE:

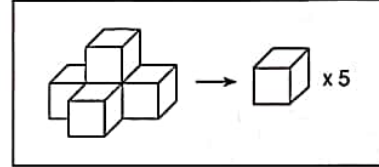

45.

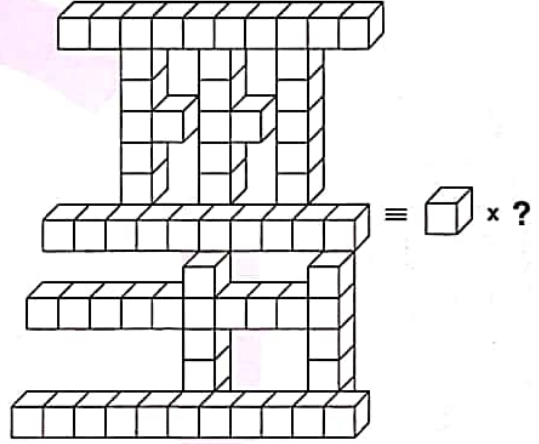

A) 64 B) 65 C) 66 D) 67 E) 68

44. I. II. III. IV.

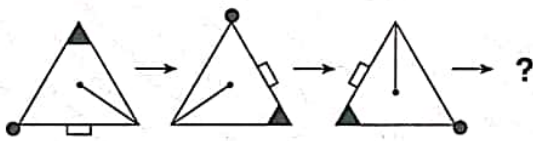

A)

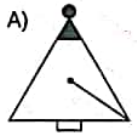

B)

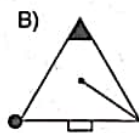

C)

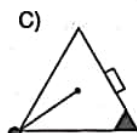

D)

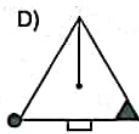

E)

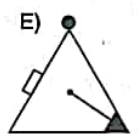

YÖS

1

46. $-a + (-a + 1) + (-a + 2) + \dots + (-a + 12) = 104$
 $\Rightarrow a = ?$

- A) -2 B) -1 C) 1 D) 2 E) 3

47. $\left[\frac{3}{4} + \frac{5}{3} \right] : 2^{-1} = ?$

- A) $\frac{5}{2}$ B) $\frac{5}{3}$ C) $\frac{25}{2}$ D) $\frac{25}{3}$ E) 5

48. $\sqrt{\frac{81}{100} + \frac{100}{81}} - 2 = ?$

- A) $\frac{15}{18}$ B) $\frac{19}{90}$ C) $\frac{12}{13}$ D) $\frac{18}{19}$ E) $\frac{80}{91}$

49. $\begin{cases} x+y=3 \\ x \cdot y=2 \end{cases} \Rightarrow x^4+y^4 = ?$

- A) 10 B) 14 C) 15 D) 17 E) 19

K
U
A
R
K
Y
A
Y
I
N
L
A
R
IK
U
A
R
K
P
U
B
L
I
C
A
T
I
O
N
S

50. Bir grup öğrenci para kazanmak için sokakta müzik yapmaktadır. k saatte kazandıkları para miktarını bulduran fonksiyon $f(k) = 14k + 2$ dir. Grup 8 saat müzik yaptığına göre kazandıkları para miktarı nedir?

A group of students are busking to raise money. The function $f(k) = 14k + 2$ gives the amount of money, in dollars, they raise by busking for k hours. If the group busked for 8 hours, what is the amount of money raised?

- A) 104 B) 114 C) 116 D) 118 E) 124

YÖS

1

51. $\frac{a}{b} = \frac{c}{d} = \frac{e}{f} = 3$
 $\Rightarrow \left(\frac{a-b}{b}\right) \cdot \left(\frac{c-d}{c}\right) \cdot \left(\frac{e+f}{e}\right) = ?$

- A) -1 B) -2 C) $\frac{4}{3}$ D) $\frac{4}{9}$ E) $\frac{16}{9}$

53. $\frac{x-1}{3} - \frac{x-2}{2} = 1 \Rightarrow x = ?$

- A) -2 B) -1 C) 0 D) 1 E) 2

54. $| -x + 2y | + | y - z | + | z - 2 | = 0$
 $\Rightarrow x + y + z = ?$

- A) -2 B) 0 C) 2 D) 4 E) 8

52.

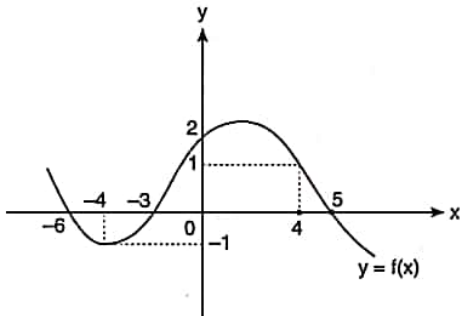

$\Rightarrow f(4) + f(-4) + (f \circ f)(5) = ?$

- A) 1 B) 2 C) 3 D) 4 E) 5

55. $Z_{/5}$
 $f(x) = 2x - 3 \Rightarrow f^{-1}(x) = ?$

- A) $2x + 1$ B) $2x + 2$ C) $2x + 3$
D) $3x + 2$ E) $3x + 4$

YÖS

1

56. $x^2 - 8x + a + 1 = 0$, $\text{ÇK(SS)} = \{x_1, x_2\}$
 $x_2 = x_1 + 4 \Rightarrow a = ?$

- A) 4 B) 7 C) 9 D) 11 E) 12

57. $P(2^x) = 2^{x+1} + 3 \cdot 4^x$
 $\Rightarrow \frac{P(x)}{?} \Big| \frac{x-1}{?}$

- A) 1 B) 2 C) 3 D) 4 E) 5

58. $\frac{x^2 - x - 6}{x^3 + 6x^2 + 12x + 8} \leq 0 \Rightarrow \text{ÇK(SS)} = ?$

- A) \emptyset B) $[-3, \infty)$ C) $(-\infty, -3]$
D) $(-\infty, 3] - \{-2\}$ E) R

59.

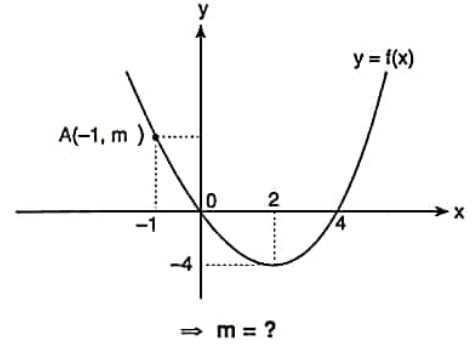

- A) 1 B) 2 C) 3 D) 4 E) 5

K U A R K Y A Y I N L A R I

K U A R K P U B L I C A T I O N S

YÖS

1

$$61. \begin{cases} \ln x^2 + \ln y = 6 \\ \ln x - 2 \ln y = 8 \end{cases} \Rightarrow \frac{x+y}{x \cdot y} = ?$$

- A) $e^2 + e^{-4}$ B) $e + e^{-1}$ C) $e^4 - e^{-2}$
 D) $e^6 - e^{-4}$ E) $e^4 - e^2$

$$63. \alpha \in \left(0, \frac{\pi}{2}\right), \cot \alpha = \frac{3}{4}$$

$$\Rightarrow \frac{\sin^3 \alpha - \cos^3 \alpha}{\sin \alpha - \cos \alpha} = ?$$

- A) $\frac{16}{9}$ B) $\frac{9}{16}$ C) $\frac{9}{25}$ D) $\frac{16}{25}$ E) $\frac{37}{25}$

K U A R K Y A Y I N L A R I

$$64. \sin 8^\circ = a \Rightarrow \sin 74^\circ = ?$$

- A) $2a^2 - 1$ B) $a^2 - 1$ C) $2a^2$
 D) $1 - 2a^2$ E) $a^2 + 1$

K U A R K P U B L I C A T I O N S

62.

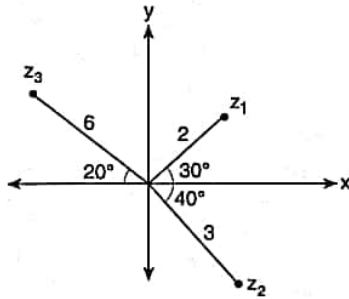

$$\Rightarrow \text{Arg} \left(\frac{z_1 \cdot z_2}{z_3} \right) = ?$$

- A) 100° B) 120° C) 150° D) 170° E) 190°

$$65. \lim_{x \rightarrow 2} \frac{3 \cdot f(x) + 2 \cdot x - 6}{f(x)} = 1 \Rightarrow \lim_{x \rightarrow 2} f(x) = ?$$

- A) -1 B) 0 C) 1 D) 2 E) 3

YÖS

1

66. $\lim_{x \rightarrow 2^+} \left(\frac{3}{x^2-4} + \frac{1}{2-x} \right) = ?$

- A) $-\infty$ B) -3 C) 0 D) 3 E) ∞

67. $\lim_{x \rightarrow \infty} \left(\frac{2x-1}{2x+1} \right)^{x^2+2} = ?$

- A) $-\infty$ B) e^{-1} C) 0 D) e^2 E) ∞

68.

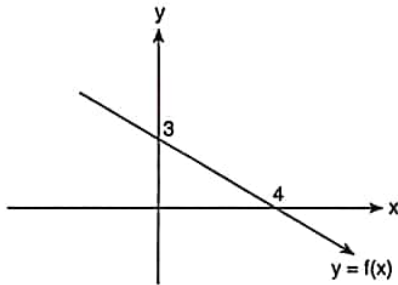

$\Rightarrow \frac{dy}{dx} = ?$

- A) $-\frac{4}{3}$ B) $-\frac{3}{4}$ C) 1 D) $\frac{3}{4}$ E) $\frac{4}{3}$

69. $2x^2 - y^2 + xy - 2 = 0 \Rightarrow \frac{dy}{dx} \Big|_{(1,1)} = ?$

- A) -5 B) $-\frac{3}{5}$ C) $-\frac{2}{5}$ D) $\frac{1}{5}$ E) 5

70. $\frac{10}{5} + \frac{20}{25} + \frac{40}{125} + \dots = ?$

- A) 10 B) 5 C) $\frac{10}{3}$ D) $\frac{5}{2}$ E) 2

71. $\int \frac{2x^3 + x^2 + x}{x} dx = ?$

- A) $\frac{2}{3}x^3 + \frac{x^2}{2} + x + C$
 B) $2x^3 + 2x^2 + \frac{x}{2} + C$
 C) $\frac{3}{2}x^3 + 2x^2 + 2x + C$
 D) $3x^3 + 2x^2 + x + C$
 E) $2x^2 + 3x^2 + x + C$

K U A R K Y A Y I N L A R I

K U A R K P U B L I C A T I O N S

YÖS

Soru 1

72. $\int_e^{e^2} \ln x \, dx = ?$

- A) -1 B) -e C) e D) e^2 E) $2e^2$

75. $\begin{bmatrix} 1 & 0 \\ 0 & 1 \end{bmatrix} + \begin{bmatrix} 2 & 0 \\ 0 & 2 \end{bmatrix} + \begin{bmatrix} 3 & 0 \\ 0 & 3 \end{bmatrix} + \dots + \begin{bmatrix} 12 & 0 \\ 0 & 12 \end{bmatrix} = ?$

- A) $\begin{bmatrix} 48 & 0 \\ 48 & 0 \end{bmatrix}$ B) $39 \cdot I_2$ C) $48 \cdot I_2$
D) $\begin{bmatrix} 36 & 0 \\ 0 & 36 \end{bmatrix}$ E) $78 \cdot I_2$

73.

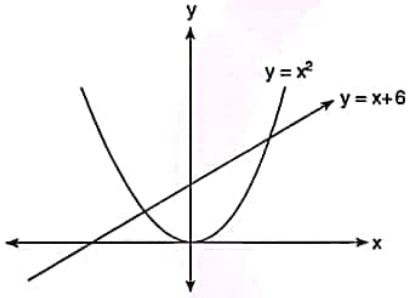

Taralı Alan / The Shaded Area = ? $br^2(u^2)$

- A) $-\frac{127}{6}$ B) -4 C) $-\frac{125}{6}$
D) $\frac{121}{3}$ E) $\frac{125}{6}$

74. $\begin{vmatrix} 2 & 0 & -1 \\ -2 & 3 & 0 \\ -3 & 1 & 2 \end{vmatrix} = ?$

- A) -6 B) -4 C) 0 D) 5 E) 6

76.

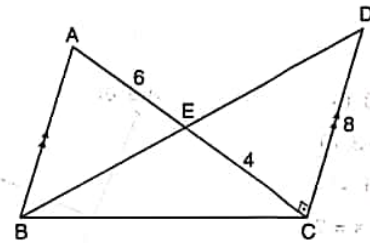

$[AB] \parallel [CD]$, $[AC] \perp [DC]$,

$|AE| = 6 \text{ cm}$, $|EC| = 4 \text{ cm}$, $|DC| = 8 \text{ cm}$

\Rightarrow Taralı Alan / The Shaded Area = ? cm^2

- A) 8 B) 16 C) 24 D) 30 E) 36

K U A R K Y A Y I N L A R I

K U A R K P U B L I C A T I O N S

YÖS

1

77. $IAEI = 8$ cm,
 $IEBI = 6$ cm,
 $IECI = (x + 2)$ cm
 $\Rightarrow IDEI = x = ?$ cm

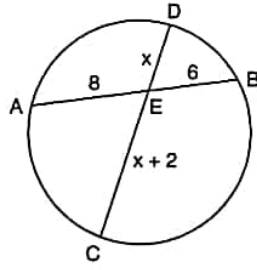

- A) 3 B) 4 C) 5 D) 6 E) 7

79.

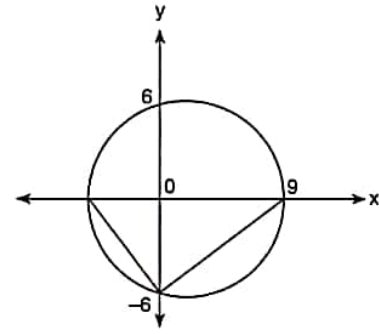

Taralı alan / The Shaded Area = ? $br^2(u^2)$

- A) 13 B) 16 C) 21 D) 27 E) 39

78. $A(3, 6)$,
 $B(-3, 8)$,
 $C(4, x)$
 $\Rightarrow x = ?$

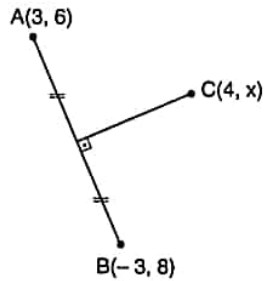

- A) 12 B) 14 C) 15 D) 18 E) 19

80. $r = 2br(u)$
 $\Rightarrow V = ? br^3(u^3)$
 $(\pi = 3)$

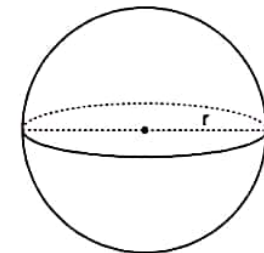

- A) 16 B) 24 C) 32 D) 36 E) 48

K U A R K Y A Y I N L A R I

K U A R K P U B L I C A T I O N S

1. $\frac{1}{3} + \frac{3}{3} + \frac{5}{3} + \dots + \frac{17}{3} = A \Rightarrow \frac{A+1}{2} = ?$

- A) 5 B) 7 C) 8 D) 9 E) 10

2. $y > x,$
 $x^2 + y^2 = 9 + 2xy \Rightarrow x = ?$

- A) $y - 1$ B) $y - 2$ C) $2 - y$
D) $3 - y$ E) $y - 3$

3. 3 kişilik bir aile 3 günlük bir kamp gezisi planlıyor. Her bir kişinin kampın her günü için 1 şişe suya ihtiyacı olacaktır. Su 3'er şişelik paketler halinde satılıyorsa bu aile yanına kaç paket su almalıdır?
A family of 3 is planning a 3-day camping trip. Each person will need 1 bottle of water for each day of the trip. If the water is sold only in 3-bottle packages, how many packages must the family buy for the trip?

- A) 2 B) 3 C) 4 D) 5 E) 6

4. $A = \sqrt{72 + \sqrt{72 + \sqrt{72 + \dots}}}$
 $B = \sqrt{12 - \sqrt{12 - \sqrt{12 - \dots}}}$ $\Rightarrow A \cdot B^{-1} = ?$

- A) $\frac{3}{4}$ B) $\frac{4}{3}$ C) $\frac{9}{4}$ D) 3 E) 4

5. $\frac{1+\sqrt{3}}{1-\sqrt{3}} - \frac{1-\sqrt{3}}{1+\sqrt{3}} = ?$

- A) $-2\sqrt{3}$ B) $-\sqrt{3}$ C) 0 D) $\sqrt{3}$ E) $2\sqrt{3}$

6. $a, b, c \in \mathbb{R}^+,$
 $a = \frac{b}{2} = \frac{c}{3},$

$a^2 + b^2 + \frac{c^2}{3} = 32 \Rightarrow \frac{b \cdot c}{a} = ?$

- A) 6 B) 8 C) 12 D) 14 E) 16

YÖS

2

7. OBEB(GCF)(x, 36, 72) = 12,
OKEK(LCM)(x, 36, 72) = $3^2 \cdot 2^4 \cdot 7 \Rightarrow \min(x) = ?$
A) 144 B) 288 C) 336 D) 272 E) 420

9. $f(x) = 2^x + 2 \Rightarrow f(2x) = ?$

- A) $f^2(x) + f(x)$ B) $f^2(x)$
C) $f^2(x) - 4 \cdot f(x) + 6$ D) $f^2(x) - 2x + 4$
E) $f^2(x) - 3 \cdot f(x) + 4$

K
U
A
R
K
Y
A
Y
I
N
L
A
R
I

8.

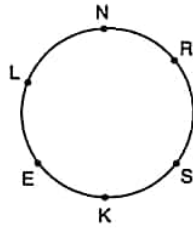

Şekildeki çember üzerinde 6 nokta verilmiştir. Köşeleri bu noktalarda olan kaç tane çokgen çizilebilir?

6 points located on the circle in the figure are given.
How many polygons can be drawn by using these points?

- A) 15 B) 20 C) 28 D) 35 E) 42

K
U
A
R
K
P
U
B
L
I
C
A
T
I
O
N
S

10.

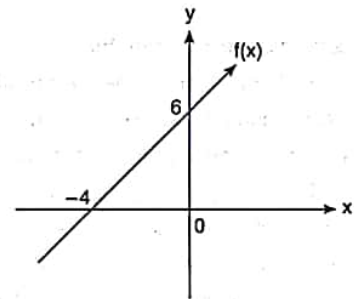

$$\Rightarrow f(1) + f(-1) = ?$$

- A) 6 B) 8 C) 10 D) 12 E) 14

YÖS

Soru 2

11. $3x + ay = -1$,
 $bx - 2y = 2$,
 $\ÇK(SS) = R \Rightarrow a + b = ?$
 A) -5 B) -4 C) -3 D) -2 E) -1

14. $A = 10! + 11! + \dots + 18!$
 $A \equiv x \pmod{10} \Rightarrow x = ?$
 A) 0 B) 1 C) 2 D) 4 E) 3

K
U
A
R
K
Y
A
Y
I
N
L
A
R
I

12. $3x - 10 \leq x + 6 \Rightarrow \ÇK(SS) = ?$
 A) \emptyset B) $(-2, \infty)$ C) $(-\infty, 4)$
 D) $(-\infty, 8]$ E) $(-\infty, 6]$

15. $\frac{P(x)}{2} \Big| \frac{x+1}{4} \Rightarrow \frac{P(x)}{?} \Big| \frac{x^2+3x+2}{?}$
 A) $-2x - 1$ B) $-2x$ C) $2x - 1$
 D) $2x + 2$ E) $3x + 2$

K
U
A
R
K
P
U
B
L
I
C
A
T
I
O
N
S

13. $||x - 1| - 3| = 6 \Rightarrow \ÇK(SS) = ?$
 A) \emptyset B) $\{-3, 6\}$ C) $\{-8, 10\}$
 D) $\{-6, 8\}$ E) $\{-4, 10\}$

16. $\frac{P(x)}{5} \Big| x$ $\frac{P(x+2)}{8} \Big| x-1$ $\frac{P(x)}{K(x)} \Big| x^2-3x$
 $\Rightarrow K(x) = ?$
 A) $-x+5$ B) $x+5$ C) $5x-1$
 D) $5x+1$ E) $-5x+1$

YÖS

2

17. $x^2 + 4x - 1 = 0$, $\text{ÇK(SS)} = \{x_1, x_2\}$
 $\Rightarrow x_1 + x_1^2 \cdot x_2 + x_2 + x_2^2 \cdot x_1 = ?$

- A) -4 B) -2 C) 0 D) 2 E) 4

19. $\left(\frac{5}{0}\right) + \left(\frac{5}{1}\right) + \left(\frac{5}{2}\right) + \left(\frac{5}{3}\right) + \left(\frac{5}{4}\right) = ?$

- A) 2^7 B) 2^6 C) $2^6 - 1$ D) 2^5 E) $2^5 - 1$

K
U
A
R
K
Y
A
Y
I
N
L
A
R
I

20. $A = 3 \cdot \sin x + 4 \cdot \cos x \Rightarrow \max(A) = ?$

- A) 5 B) 6 C) 7 D) 8 E) 9

K
U
A
R
K
P
U
B
L
I
C
A
T
I
O
N
S

18.

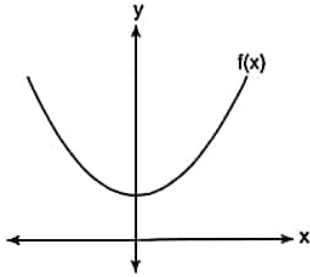

$f(x) = x^2 + ax + 1 \Rightarrow a \in (?, ?)$

- A) (0, 2) B) (-2, 0] C) (-2, 2)
 D) (2, ∞) E) ($-\infty$, 2)

21. $a \cdot \cos x - \sin x = a$
 $\Rightarrow a = ?$

- A) $-\tan \frac{x}{2}$ B) $\cot \frac{x}{2}$ C) $\sec \frac{x}{2}$
 D) $\operatorname{cosec} \frac{x}{2}$ E) $-\cot \frac{x}{2}$

YÖS

2

22. $\frac{\sin 36^\circ}{\sin 12^\circ} - \frac{\cos 36^\circ}{\cos 12^\circ} = ?$

- A) $-\frac{1}{2}$ B) -1 C) $\frac{1}{2}$ D) 1 E) 2

25. $x \in \mathbb{Z}$,

$$\log_4 9 + \log_2 (x-3) < 4 \Rightarrow \sum x = ?$$

- A) 22 B) 30 C) 33 D) 35 E) 36

K
U
A
R
K
Y
A
Y
I
N
L
A
R
I

23. $\log_2 3 = a \Rightarrow \log_6 24 = ?$

- A) $\frac{a}{a+1}$ B) $\frac{a+2}{a+1}$ C) $\frac{a+3}{a+2}$
D) $\frac{a+3}{a+1}$ E) $\frac{a+2}{a+3}$

26. $z_1 = -2i$,

$$z_2 = 4 \Rightarrow |z_1| + |z_2| = ?$$

- A) 2 B) 4 C) 6 D) $2\sqrt{5}$ E) $2\sqrt{3}$

K
U
A
R
K
P
U
B
L
I
C
A
T
I
O
N
S

24. $\ln(\log_3 (\ln(x-1)^3)) = 0 \Rightarrow x = ?$

- A) $-e$ B) $1-e$ C) $e-1$ D) $e+1$ E) e

27. $\lim_{x \rightarrow 0} \left(\frac{\sin 2x}{\cos 4x} - 1 \right) = ?$

- A) $-\infty$ B) -1 C) 0 D) 1 E) ∞

YÖS

2

28. $f(x) = (x^2 - x + 1)$, $g(x) = (x - 1)^2$

$$\Rightarrow \lim_{x \rightarrow 1} \left[\frac{f(x) + g(x)}{f^2(x)} + 2 \cdot g(x) \right] = ?$$

- A) $-\infty$ B) -1 C) 1 D) 2 E) ∞

29. $f(x) = x^3 - x \Rightarrow \lim_{x \rightarrow 2} \left(\frac{f(x) - f(2)}{x - 2} \right) = ?$

- A) 8 B) 9 C) 10 D) 11 E) 12

30. $f(2x) = \sin x \Rightarrow f'(2\pi) = ?$

- A) $-\frac{1}{2}$ B) 0 C) $\frac{1}{2}$ D) 1 E) 2

31. $\int \tan^2 x dx + \int dx = ?$

- A) $\ln|\cos x| + x + C$
 B) $\ln|\cos x| + \frac{x}{2} + C$
 C) $\ln|\sin x| + x + C$
 D) $\cot x + C$
 E) $\tan x + C$

K
U
A
R
K
Y
A
Y
I
N
L
A
R
IK
U
A
R
K
P
U
B
L
I
C
A
T
I
O
N
S

32. $A = \begin{bmatrix} 1 & -2 \\ 1 & 2 \end{bmatrix} \Rightarrow \det(A^2) = ?$

- A) 1 B) 2 C) 4 D) 9 E) 16

YÖS

2

33.

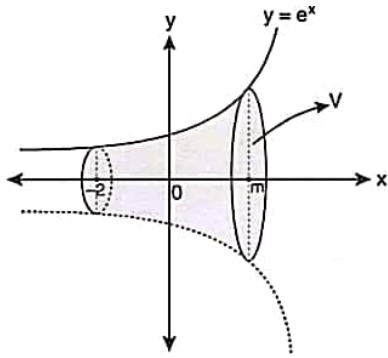

$$V = \frac{\pi}{2}[e^6 - e^{-4}]br^3(u^3) \Rightarrow m = ?$$

- A) 1 B) 2 C) 3 D) 4 E) 5

35.

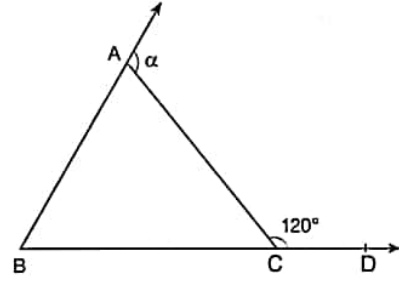

$$m(\widehat{ACD}) = 120^\circ, m(\widehat{BAC}) = 3 \cdot m(\widehat{ABC}) \Rightarrow \alpha = ?$$

- A) 80° B) 90° C) 100° D) 110° E) 120°

34. $a, b \in \mathbb{Z}$,

$$\begin{vmatrix} a & 2 \\ 3 & b \end{vmatrix} = 1 \Rightarrow \min(a+b) = ?$$

- A) -12 B) -10 C) -8 D) 6 E) 8

36.

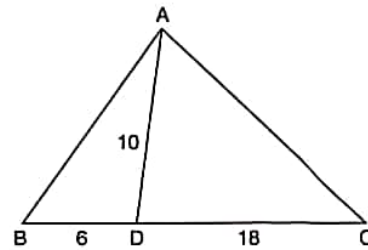

$$|AB| = |AC|, |AD| = 10 \text{ cm}, |BD| = 6 \text{ cm},$$

$$|DC| = 18 \text{ cm} \Rightarrow |AB| = ? \text{ cm}$$

- A) $\sqrt{29}$ B) $2\sqrt{29}$ C) $2\sqrt{13}$
D) $4\sqrt{13}$ E) $5\sqrt{29}$

YÖS

2

37. $IAFI = 6$ cm,
 $IFBI = 5$ cm,
 $IBDI = 4$ cm,
 $IDCI = 7$ cm,
 $IECI = 6$ cm
 $\Rightarrow IAEI = x = ?$ cm

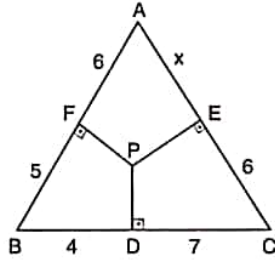

- A) $\sqrt{14}$ B) $2\sqrt{7}$ C) $\sqrt{42}$ D) $3\sqrt{7}$ E) $\sqrt{7}$

39.

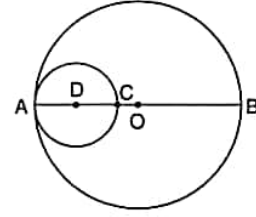

D ve O noktaları çemberlerin merkezleridir.

points D and O are centers of the circles.

$$IACI = 2 \cdot IOCI,$$

$$TA/SA = 32\pi \text{ cm}^2$$

$$\Rightarrow IADI = ? \text{ cm}$$

- A) 1 B) 2 C) 3 D) 4 E) 5

38.

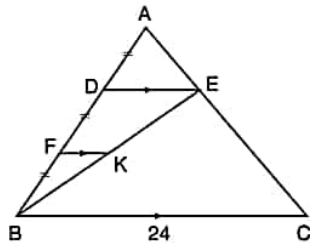

$$[DE] \parallel [FK] \parallel [BC], IADI = IDFI = IFBI,$$

$$IBCI = 24 \text{ cm} \Rightarrow IDEI + IFKI = ? \text{ cm}$$

- A) 6 B) 10 C) 12 D) 16 E) 18

40.

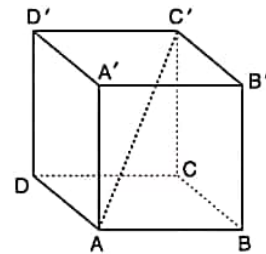

$ABCD A'B'C'D'$ bir küptür. / $ABCD A'B'C'D'$ is a cube.

$$A(ABCD A'B'C'D') = 54 \text{ cm}^2 \Rightarrow IAC'I = ? \text{ cm}$$

- A) 2 B) $2\sqrt{3}$ C) 3 D) $3\sqrt{3}$ E) $3\sqrt{2}$

41, 42, 43 ve 44. sorularda I. gruptaki her bir harf, rakam veya şekil, II. gruptaki farklı birer harf, rakam veya şekil ile gösterilmiştir. Buna göre, soru işaretleriyle belirtilen harfleri, rakamları veya şekilleri bulunuz. In questions 41, 42, 43 and 44 each letter, numeral or figure in group I stand for a different letter, numeral or figure in group II. Accordingly, find the letters, numerals or figures which the questions mark stands for.

41.

I.	II.
1 2 3 1 4	K O R L U
5 2 3 6 4	Z O R L U
7 4 3 6 4	B U R G U
8 2 3 9 4	S O R G U
1 2 3 9 4	K O R K U

$$\Rightarrow 74364 = ?$$

- A) KORLU B) ZORLU C) BURGU
D) SORGU E) KORKU

42.

I.	II.
Ş İ N E G	6 3 5 2 6
N İ R E N	6 3 4 2 0
N İ R A N	9 3 6 2 7
N İ Y E B	6 3 5 1 6
N A R A Y	6 1 5 1 4

$$\Rightarrow \text{NİRAN} = ?$$

- A) 63526 B) 63420 C) 93627
D) 63516 E) 61514

43.

I.	II.
1 2 9 8 7 6	?
5 4 3 2 9 0	
1 8 7 3 5 8	
7 6 8 9 0 2	

A) R C N L M K F T Ü N C F R L M Ü F L M Ç L N E C	B) R C N L M Ç F T Ü C N B R L M Ü F L M Ç L N B C
---	---

C) R C N M M Ç F T Ü C N F R L M Ü F L M Ç L N B C	D) R C N L M Ç F T Ü C N B L R M Ü F L M L Ç N B C
---	---

E) R C N L M Ç F T Ü C N B R L M F Ü L M Ç L N C B

44.

I.	II.
T L M N B	?
C S A N F	
B M T Ç C	
A F Ç S L	

A) 6 2 3 5 7 8 4 1 5 9 3 7 4 0 8 1 5 0 4 2	B) 6 2 3 5 7 8 4 1 5 9 3 6 6 0 8 1 9 4 4 2
---	---

C) 6 2 3 5 7 8 4 1 5 9 3 7 4 8 0 1 9 0 8 2	D) 6 2 3 5 7 8 4 1 5 9 7 3 6 0 8 1 9 0 4 2
---	---

E) 4 2 3 5 7 8 4 1 5 9 7 3 6 9 0 1 9 2 0 4

45, 46 ve 47. sorulardaki verilen işlemlerde her harf sıfırdan ve birbirinden farklı birer rakamı göstermektedir. Buna göre, soru işareti ile belirtilen harf ya da işlemin değerini bulunuz.

In the operations which are given in questions 45, 46 and 47 each letter stands for a different non-zero numeral. Accordingly, find the value of the letter or operation indicated by the questions mark.

$$45. \begin{array}{r} KK \\ LL \\ + MM \\ \hline KLK \end{array} \Rightarrow M = ?$$

- A) 1 B) 2 C) 7 D) 8 E) 9

$$46. \begin{array}{r} LLL \\ - KMM \\ \hline LM \end{array} \Rightarrow K = ?$$

- A) 9 B) 8 C) 7 D) 6 E) 5

$$47. \begin{array}{r} KL \\ MN \\ + TR \\ \hline VYZ \end{array} \Rightarrow \max(V) = ?$$

- A) 9 B) 8 C) 7 D) 2 E) 1

$$48. \text{ I. } \frac{5-a}{1 + \frac{b}{a \Delta b}} = a + 2 \cdot b$$

$$\text{ II. } 2 \Delta 3 = ?$$

Yukarıdaki birinci eşitlikte Δ işaretinin görevi verilmiştir. Buna göre, ikinci eşitlikteki soru işaretinin yerine aşağıdaki sayılardan hangisi gelmelidir?

In the first equation above, the function of Δ is given. Accordingly, which of the following numbers does the question mark stand for in the second equation?

- A) 6 B) 8 C) 12 D) 16 E) 18

$$49. \text{ I. } 987 \bullet = 31$$

$$\text{ II. } 653 \bullet = 17$$

$$\text{ III. } 489 \bullet = 30$$

$$\text{ IV. } 512 \bullet = ?$$

Yukarıdaki eşitliklerde \bullet işaretinin görevi verilmiştir. Buna göre, dördüncü eşitlikteki soru işaretinin yerine aşağıdaki sayılardan hangisi gelmelidir?

In the equations above, the function of \bullet is given.

Accordingly, which of the following numbers does the question mark stand for in the fourth equation?

- A) 10 B) 14 C) 16 D) 22 E) 35

YÖS

2

50. I. $a^3 \blacktriangle b^4 = \frac{a+b}{b-a}$

II. $2 \cdot a \blacksquare \frac{b}{3} = a \cdot b$

III. $9 \cdot a \blacklozenge \frac{b}{2} = a + b$

IV. $(6 \blacksquare 5) \blacklozenge (27 \blacktriangle 625) = ?$

Yukarıdaki eşitliklerde \blacktriangle , \blacksquare ve \blacklozenge işaretlerinin görevleri verilmiştir. Buna göre, dördüncü eşitlikteki soru işaretinin yerine aşağıdaki sayılardan hangisi gelmelidir?

In the equations above, the functions of \blacktriangle , \blacksquare and \blacklozenge are given. Accordingly, which of the following numbers does the question mark stand for in the fourth equation?

- A) 13 B) 14 C) 35 D) 40 E) 49

51. I. $x \nabla y = x \blacksquare 2y$

II. $x \blacksquare y = (x + 1) \blacktriangle y$

III. $x \blacktriangle y = x^y$

IV. $1 \nabla 4 = ?$

Yukarıdaki eşitliklerde ∇ , \blacksquare ve \blacktriangle işaretlerinin görevleri verilmiştir. Buna göre, dördüncü eşitlikteki soru işaretinin yerine aşağıdaki sayılardan hangisi gelmelidir?

In the equations above, the functions of ∇ , \blacksquare and \blacktriangle are given. Accordingly, which of the following numbers does the question mark stand for in the fourth equation?

- A) 64 B) 128 C) 256 D) 512 E) 1024

52 ve 53. soruları aşağıdaki şekile göre cevaplayınız.
Answer questions 52 and 53 in accordance with the figure given below.

Her soru birbirinden bağımsız olarak cevaplanacaktır.
Each question is to be answered independently.

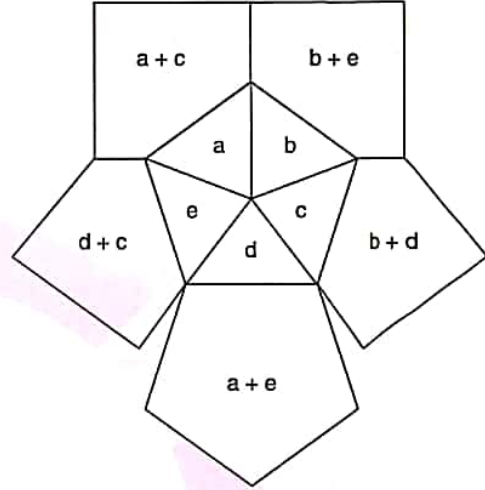

Yukarıdaki şekil a, b, c, d ve e harfleriyle gösterilen beş pozitif tamsayıyı içeren bazı işlemlere göre düzenlenmiştir. Harflerin gösterdiği sayılar her soruda farklı olabilir; fakat yapılacak işlemler her soruda aynıdır.

The figure above has been organized according to various operations using five positive integers represented by the letters a, b, c, d and e. The integers represented by the letters may change from question to question, but the operations to be done remain the same.

K
U
A
R
K
Y
A
Y
I
N
L
A
R
IK
U
A
R
K
P
U
B
L
I
C
A
T
I
O
N
S

YÖS

2

52.

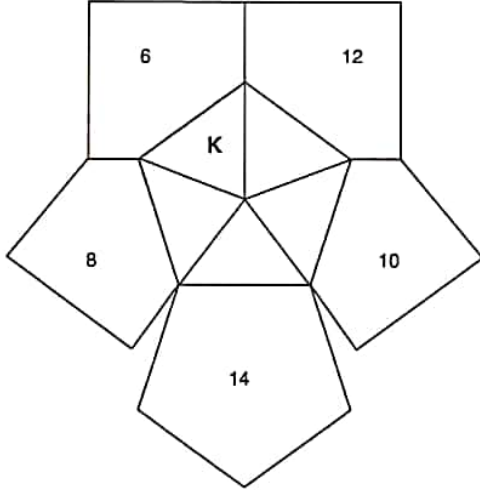

$$\Rightarrow K = ?$$

- A) 1 B) 3 C) 5 D) 7 E) 9

53.

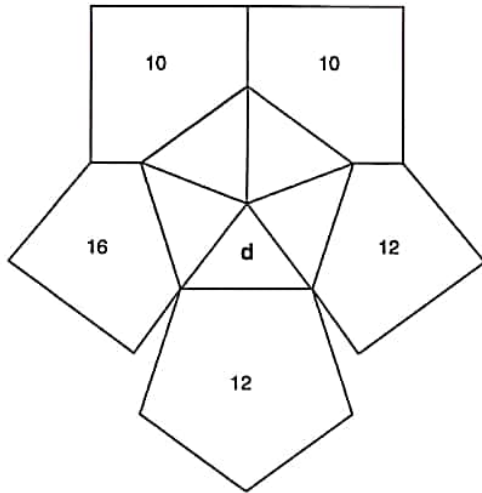

$$\Rightarrow d = ?$$

- A) 10 B) 8 C) 6 D) 4 E) 2

54.

+	a	b	c
a		2c+1	
b		18	
c	10		

$$\Rightarrow a = ?$$

Yukarıdaki toplama tablosunda a, b ve c harfleri pozitif birer tam sayının yerine kullanılmıştır. Buna göre, a kaçtır?

In the summation table above, the letters a, b and c each stands for a positive integer. Accordingly, what is the value of a?

- A) 4 B) 5 C) 6 D) 8 E) 9

55.

x	a	b	c
a		120	
b			80
c	96		

$$\Rightarrow a + b + c = ?$$

Yukarıdaki çarpma tablosunda a, b ve c harfleri pozitif birer tam sayının yerine kullanılmıştır. Buna göre, a + b + c kaçtır?

In the multiplication table above, the letters a, b and c each stands for a positive integer. Accordingly, what is the value of a + b + c?

- A) 28 B) 29 C) 30 D) 31 E) 32

K U A R K Y A Y I N L A R I

K U A R K P U B L I C A T I O N S

YÖS

2

56.

+	a	b	c
a			3a
b			
c			

x	a	b	c
a			32
b			
c		48	

$$\Rightarrow b = ?$$

Yukarıdaki toplama ve çarpma tablolarında a, b ve c harfleri pozitif birer tam sayının yerine kullanılmıştır. Buna göre, b kaçtır?

In the summation and multiplication tables above, the letters a, b and c each stands for a positive integer.

Accordingly, what is the value of b?

- A) 5 B) 6 C) 7 D) 8 E) 9

57.

+	a	b	c
a			2b
b	20		
c			

x	a	b	c
a	64		
b			
c			

$$\Rightarrow c = ?$$

Yukarıdaki toplama ve çarpma tablolarında a, b ve c harfleri pozitif birer tam sayının yerine kullanılmıştır. Buna göre, c kaçtır?

In the summation and multiplication tables above, the letters a, b and c each stands for a positive integer.

Accordingly, what is the value of c?

- A) 20 B) 16 C) 12 D) 8 E) 4

58.

I.  $\equiv 5 + \frac{7}{12}$

II.  $\equiv \frac{53}{8}$

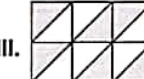
III.  $\equiv ?$

I. ve II. satırlarda belirlenen ilişkiye göre, III. satırı aşağıdaki sayılardan hangisi tamamlar?

Which of the following numbers completes III, in accordance with the relation established in I and II?

- A) $\frac{13}{2}$ B) $\frac{15}{2}$ C) $\frac{17}{2}$ D) 3 E) 9

59.

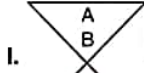
I.  $\rightarrow 2, 1, 2, 1$

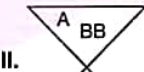
II.  $\rightarrow 2, 2, 1, 1$

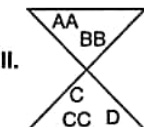
III.  $\rightarrow ?$

I. ve II. satırlarda belirlenen ilişkiye göre, III. satırı aşağıdaki sayılardan hangisi tamamlar?

Which of the following numbers completes III, in accordance with the relation established in I and II?

- A) 3, 1, 2, 2 B) 3, 2, 1, 2 C) 1, 2, 2, 3
D) 1, 2, 3, 2 E) 2, 2, 3, 1

K U A R K Y A Y I N L A R I

K U A R K P U B L I C A T I O N S

YÖS

2

60.

	I	II	III
	5	K	2
	L	3	1
	6	2	M

 $\Rightarrow K = ? ; L = ? ; M = ?$

Yukarıdaki tabloya göre K, L ve M kaçtır?

According to the table above, what are the value of K, L and M, respectively?

- A) 5; 2; 2 B) 5; 2; 1 C) 5; 1; 2
D) 2; 2; 5 E) 2; 5; 2

61.

		?

Yukarıdaki tabloya göre soru işaretinin yerine hangi şekiller gelmelidir?

According to the table above, which of the figures does the question mark stand for?

- A) B) C)
D) E)

62. soruyu aşağıdaki örnekte verilen ilişkiye göre cevaplayınız.

Answer question 62, in accordance with the relation established in the example below.

ÖRNEK / EXAMPLE:

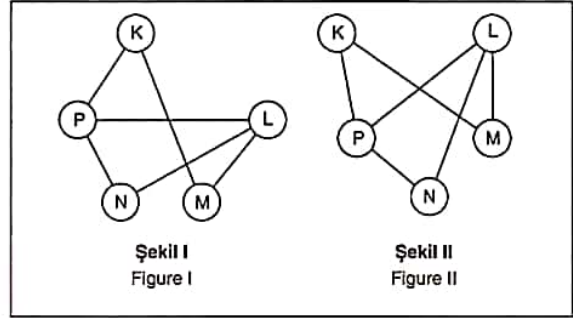

K, L, M, N ve P harfleri I. şekildeki gibi birbirine bağlanmıştır. I. şekildeki bağlantı sayıları ve birbirine bağlanan harfler değişmemek koşuluyla II. şekil elde edilmiştir.

The letters K, L, M, N and P are linked as in figure I. figure II has been constructed so as not to change the number of links and the letters that are linked to each other in figure I.

62.

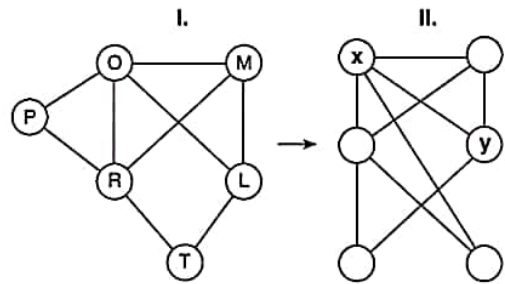

 $\Rightarrow x = ? ; y = ?$

- A) R; L B) R; P C) R; M
D) O; L E) O; M

YÖS

2

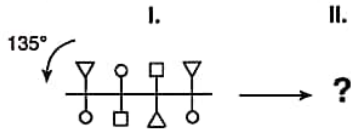
63.



Yukarıdaki şekil aynı düzlem üzerinde ok yönünde 135° döndürülürse aşağıdaki şekillerden hangisi oluşur?

If the figure above is rotated through 135° in the direction of the arrow on the same plane, which of the following figures is obtained?

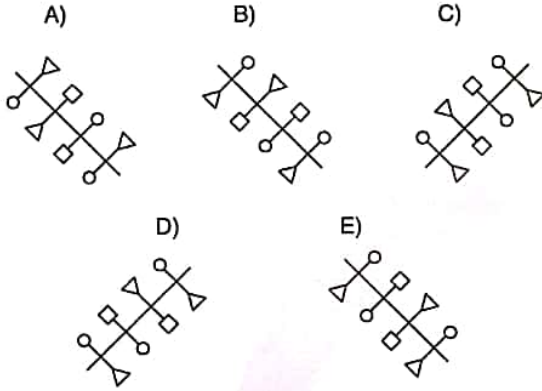

64.

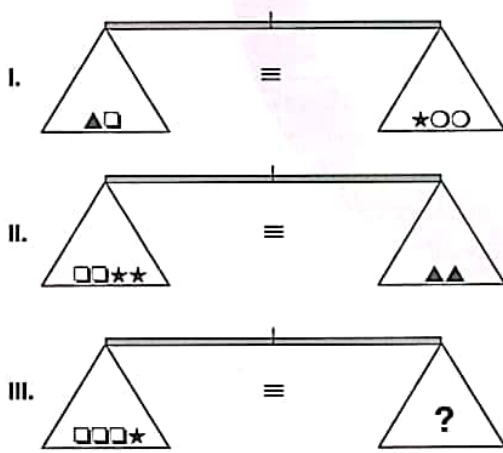

Yukarıdaki terazilerin üçü de dengededir. Buna göre, III. terazideki soru işaretini aşağıdakilerden hangisi göstermektedir?

All three scales above are in balance. Accordingly, which of the following does the question mark stand for in the third scale?

- A) ▲ B) ○ C) ▲▲
D) ○○ E) ▲○○

65.

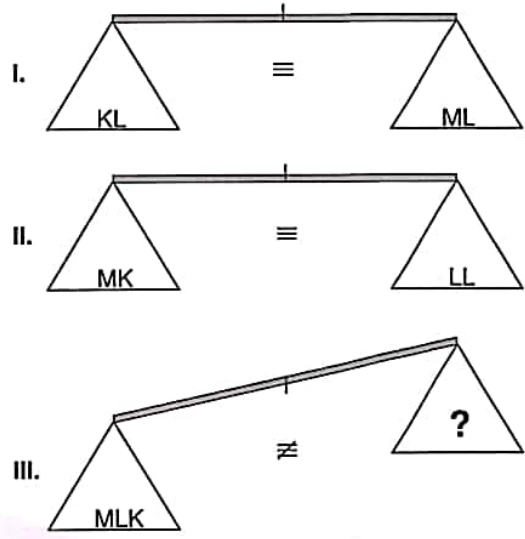

Yukarıdaki terazilerin ilk ikisi dengede olup, üçüncüsü dengede değildir. Buna göre, III. terazideki soru işaretini aşağıdakilerden hangisi göstermektedir?

First two scales above are in balance, the third scale is not in balance. Accordingly, which of the following does the question mark stand for in the third scale?

- A) KKK B) LLKK C) LLK
D) KK E) MMK

K U A R K Y A Y I N L A R I

K U A R K P U B L I C A T I O N S

66, 67 ve 68. sorularda, I. satırda belirlenen ilişkiye göre II. satırı hangi şeklin tamamladığını bulunuz.

In questions 66, 67 and 68, find the figure which completes row II, in accordance with the relation in row I.

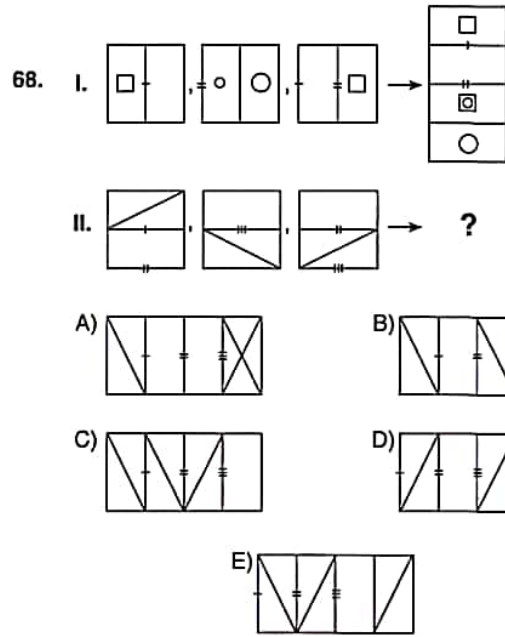
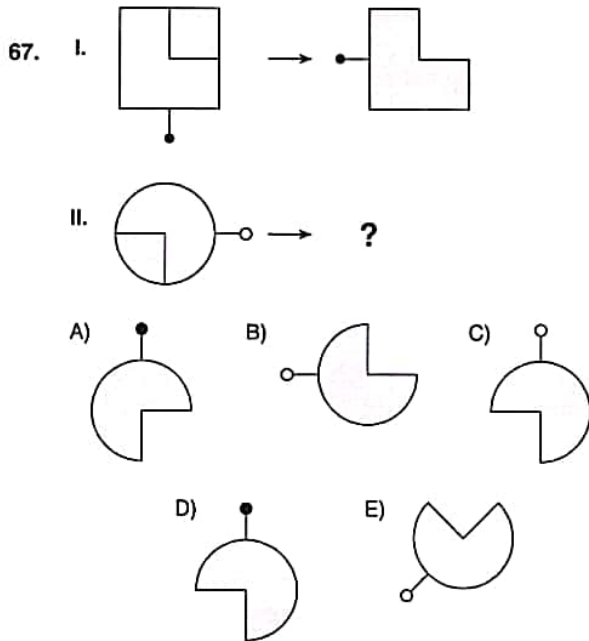
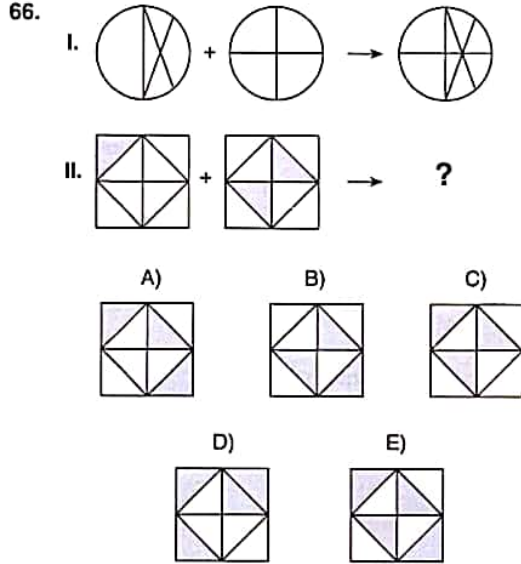

69, 70 ve 71. sorularda, verilen her bir şekil dizisindeki soru işaretinin yerine hangi şeklin getirilmesi gerektiğini bulunuz.

In questions 69, 70 and 71 find the figure which should replace the question mark in each given figure sequence.

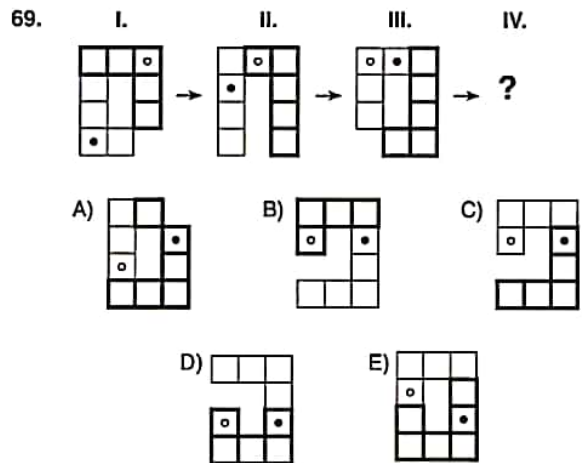

YÖS

2

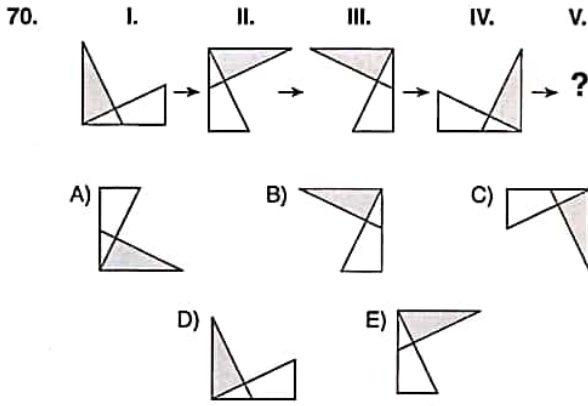

72, 73, 74 ve 75. sorularda, verilen her bir şekil matrisindeki soru işaretinin yerine hangi şeklin getirilmesi gerektiğini bulunuz.

In questions 72, 73, 74 and 75, find the figure which should replace the question mark in each given figure matrix.

72.

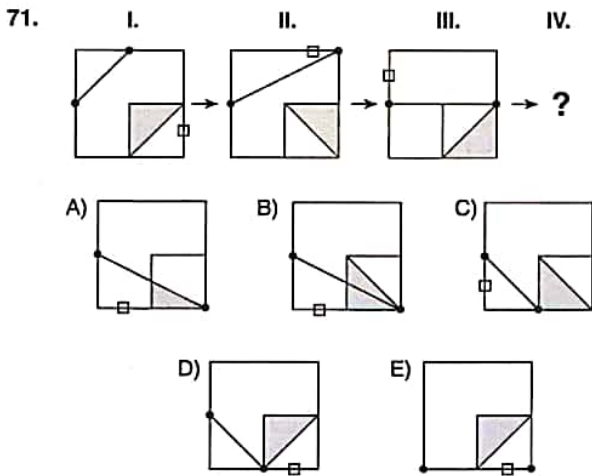
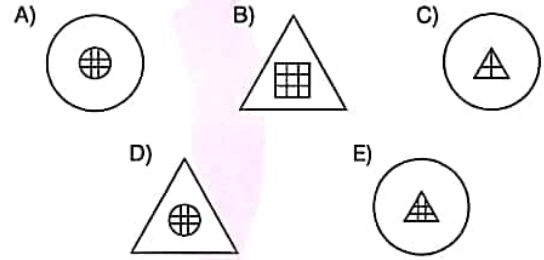
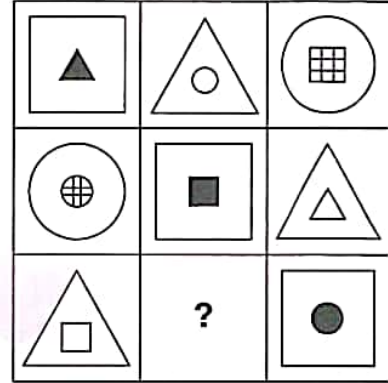

YÖS

2

73.

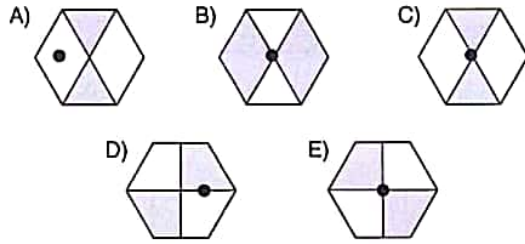
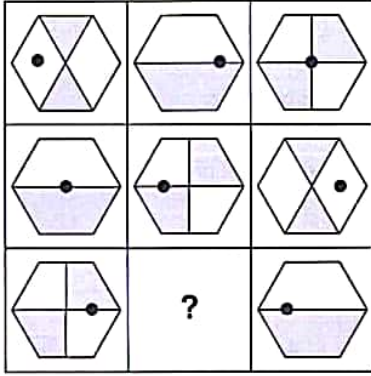

74.

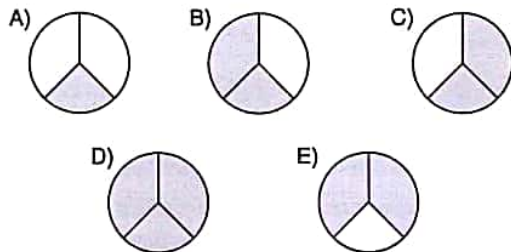
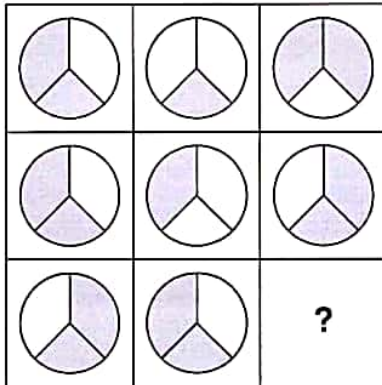

75.

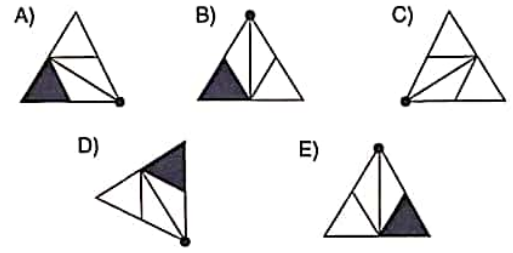
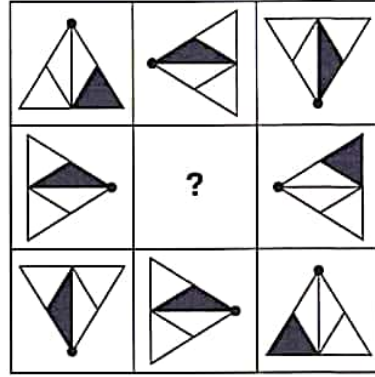

76. soruda, soru işaretinin yerine getirilmesi gereken şekli bulunuz.

In question 76, find the figure to replace the question mark.

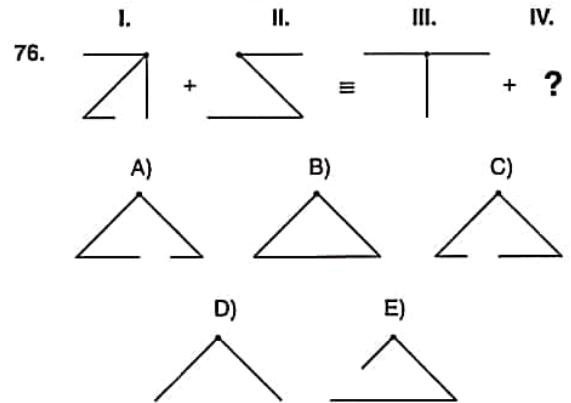

K U A R K Y A Y I N L A R I

K U A R K P U B L I C A T I O N S

YÖS

2

77.

I.

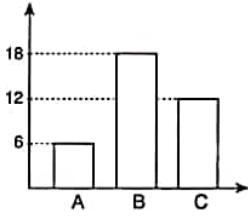

II.

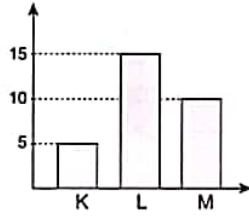

$$\Rightarrow \frac{C+B}{M+K} - 1 = ?$$

Yukarıdaki I. ve II. sütun grafikler arasındaki ilişkiye göre, $\frac{C+B}{M+K} - 1$ kaçtır?

What is the value of $\frac{C+B}{M+K} - 1$, according to the relation between column charts-charts I and II above?

- A) 0 B) 1 C) 2 D) 3 E) 4

78. soruyu aşağıdaki örnekte verilen ilişkiye göre cevaplayınız.

Answer question 78, in accordance with the relation established in the example below.

ÖRNEK / EXAMPLE:

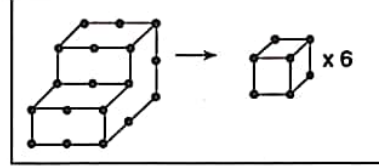

78.

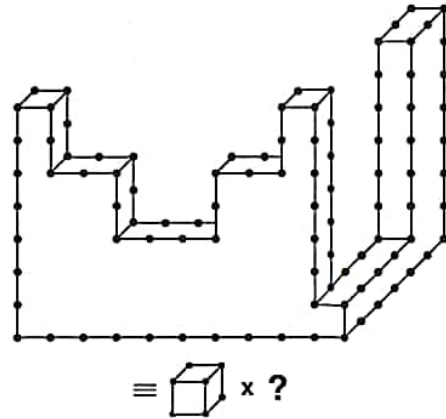

- A) 59 B) 60 C) 61 D) 62 E) 63

YÖS

2

79. soruyu aşağıdaki örnekte verilen ilişkiye göre cevaplayınız.

Answer question 79, in accordance with the relation established in the example below.

ÖRNEK / EXAMPLE:

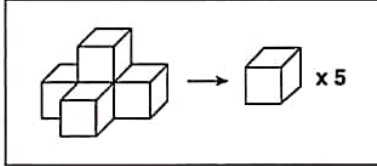

79.

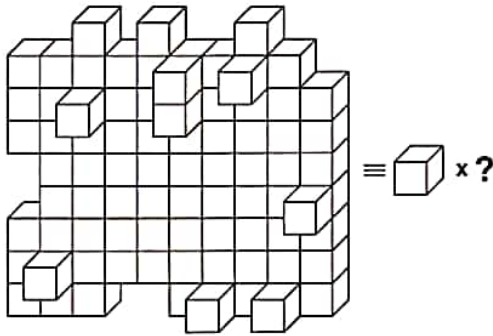

- A) 83 B) 84 C) 85 D) 86 E) 87

80.

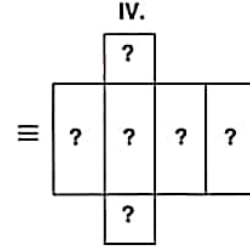
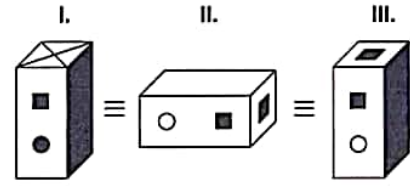

Yukarıdaki şekillerin tümü aynı prizmayı göstermektedir. Buna göre, aşağıdakilerden hangisi bu prizmanın açılmış halidir?

The figures above represent the same prism. Accordingly, which of the following represents the unfolded form of this prism?

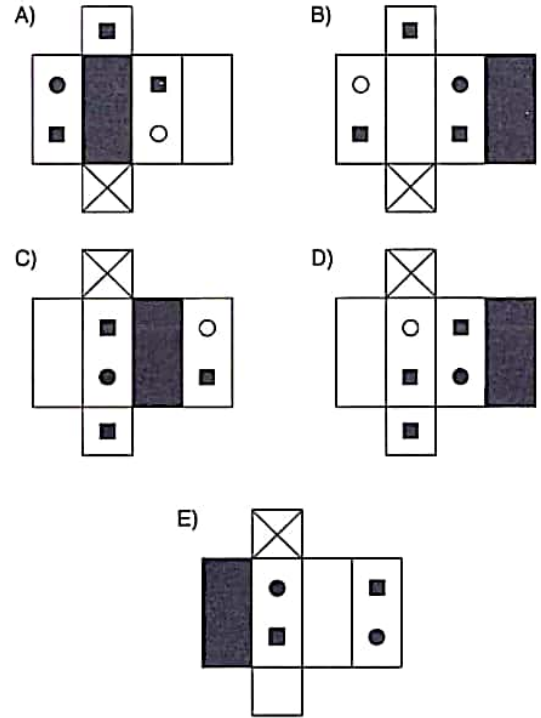

K U A R K Y A Y I N L A R I

K U A R K P U B L I C A T I O N S

1.

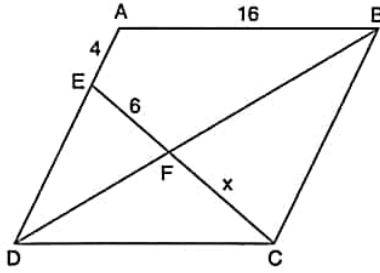

ABCD bir eşkenar dörtgendir.

ABCD is an equilateral quadrangle.

$|AE| = 4$ cm, $|AB| = 16$ cm,

$|EF| = 6$ cm $\Rightarrow |FC| = x = ?$ cm

- A) 4 B) 6 C) 8 D) 9 E) 10

2.

$[AB] \parallel [DC]$,

$[AE] \perp [AD]$,

$|BE| = |EC|$,

$|AD| = 6$ cm,

$|AE| = 8$ cm

$\Rightarrow A(ABCD) = ?$ cm²

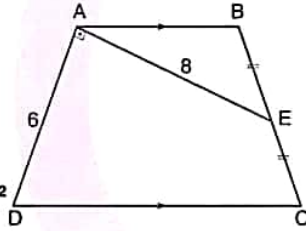

- A) 16 B) 24 C) 32 D) 48 E) 52

3.

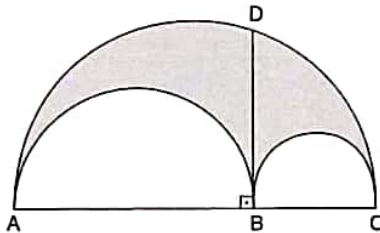

$[AB]$, $[AC]$, $[BC]$ çaplı yarım çemberler şekildeki gibi verilmiştir. / Half-circles with diameter of $[AB]$, $[AC]$, $[BC]$ were given above.

$|DB| = 8$ cm,

\Rightarrow Taralı alan / The Shaded Area = ? cm² dir.

- A) 8π B) 12π C) 16π D) 24π E) 32π

4.

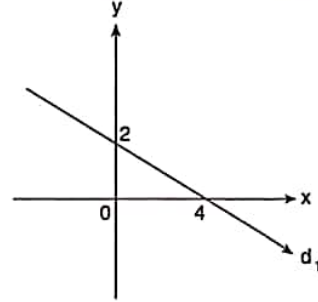

$\Rightarrow d_1 = ?$

A) $x + 2y - 4 = 0$

B) $2x + y - 4 = 0$

C) $x + y - 2 = 0$

D) $x + y - 4 = 0$

E) $x - 2y - 4 = 0$

5.

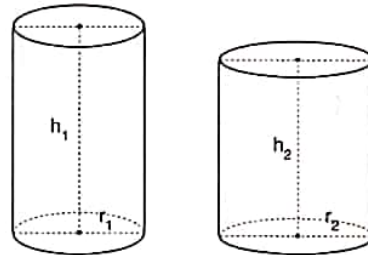

$3 \cdot r_1 = 2 \cdot r_2$, $h_1 = 2 \cdot h_2 \Rightarrow \frac{V_1}{V_2} = ?$

- A) $\frac{1}{2}$ B) $\frac{3}{4}$ C) $\frac{6}{7}$ D) $\frac{7}{8}$ E) $\frac{8}{9}$

YÖS

3

6. $\frac{\frac{3}{4}}{\frac{1}{2} + \frac{1}{3}} + \left(\frac{10}{11}\right)^{-1} = ?$

- A) 1 B) $\frac{3}{2}$ C) 2 D) $\frac{5}{2}$ E) 3

8.

İÇEÇEK BEVERAGES	FİYAT / PRICE	
	küçük / tall	büyük / grande
Espresso	1.50 TL	2.50 TL
Latte	3.50 TL	4.75 TL
Mocha	5.50 TL	6.75 TL

Aşağıdakilerden hangisi 1 küçük Espresso, 2 büyük Latte ve bir küçük Mocha alan birinin ödeyeceği miktardır?

Which of the following is the amount of money paid when one purchases 1 tall Espresso, 2 grande Latte and 1 tall Mocha?

- A) 24.00 TL B) 15.00 TL C) 16.00 TL
D) 16.50 TL E) 16.75 TL

K
U
A
R
K
Y
A
Y
I
N
L
A
R
IK
U
A
R
K
P
U
B
L
I
C
A
T
I
O
N
S

7. $x^2 - 5x = 3 \Rightarrow x^2 + \frac{9}{x^2} = ?$

- A) 28 B) 29 C) 30 D) 31 E) 32

9. $\left. \begin{array}{l} 2^x = a \\ 3^x = b \\ 5^x = c \end{array} \right\} \Rightarrow \left(\frac{100}{3}\right)^x = ?$

- A) $a^2 \cdot b^2 \cdot c$ B) $\frac{a^2 \cdot b}{c}$ C) $\frac{a^2 \cdot c^2}{b}$
D) $\frac{a^2 \cdot b^2}{c}$ E) $\frac{a^2 \cdot c}{b^2}$

YÖS

3

$$10. \begin{cases} \sqrt{2} = x \\ \sqrt{3} = y \\ \sqrt{5} = z \end{cases} \Rightarrow \sqrt{3,6} = ?$$

- A) $\frac{x^2y}{z}$ B) $\frac{x^2y^2}{z}$ C) $\left(\frac{xy}{z}\right)^2$
 D) $\frac{xy^2}{z}$ E) $\frac{xy}{z}$

$$11. \begin{cases} 2a + 3b = 16 \\ 5a + 7b = 12 \end{cases} \Rightarrow \frac{a}{b} = ?$$

- A) $-\frac{19}{14}$ B) $-\frac{16}{17}$ C) $\frac{8}{7}$ D) $\frac{9}{8}$ E) $\frac{19}{7}$

$$12. A = \{1, 2, 3, 4, 5\}, f: A \rightarrow A$$

$$f = \begin{pmatrix} 1 & 2 & 3 & 4 & 5 \\ 3 & 4 & 5 & 2 & 1 \end{pmatrix} \Rightarrow (f \circ f^{-1} \circ f)(5) = ?$$

- A) 1 B) 2 C) 3 D) 4 E) 5

13.

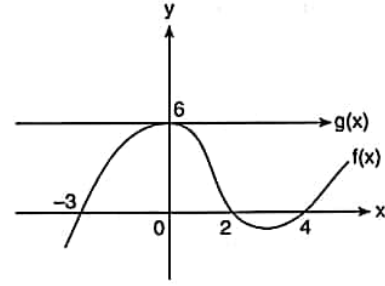

$$\Rightarrow (g \circ f)(4) + (g \circ f)(-3) = ?$$

- A) -2 B) 0 C) 2 D) 8 E) 12

$$14. \begin{cases} 3x + 2y + z = 18, \\ 2x + y + 2z = 12, \\ 2x + 2y + 4z = 24 \end{cases} \Rightarrow x + y + z = ?$$

- A) 6 B) 8 C) 10 D) 12 E) 14

K U A R K Y A Y I N L A R I

K U A R K P U B L I C A T I O N S

YÖS

3

15. $10^x = 108$

$\Rightarrow |x - 2| + |x - 3| = ?$

- A) -1 B)
- $5 - 2x$
- C) 1 D) 5 E)
- $2x - 5$

16. $P(x) = (x^6 - 2x^4 + x^2)^2 \cdot (x^5 - 2x + 4)^3$

$\text{der}[P^n(x)] = 54 \Rightarrow n = ?$

- A) 1 B) 2 C) 3 D) 4 E) 5

17. $x^6 + 2x^3 - 3 = 0 \Rightarrow \text{ÇK(SS)} = ?$

- A)
- $\{-1, 1\}$
- B)
- $\{-\sqrt{3}, \sqrt{3}\}$
- C)
- $\{-1, \sqrt{3}\}$
-
- D)
- $\{\sqrt[3]{-3}, 1\}$
- E)
- $\{-1, \sqrt[3]{3}\}$

18.

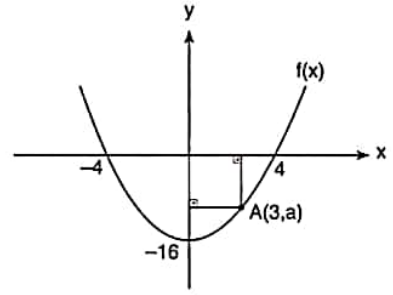
 \Rightarrow Taralı alan / The shaded area = ? cm^2

- A)
- $\frac{9}{2}$
- B) 6 C) 10 D) 21 E)
- $\frac{27}{2}$

K
U
A
R
K
Y
A
Y
I
N
L
A
R
IK
U
A
R
K
P
U
B
L
I
C
A
T
I
O
N
S

19. $f(x) = \log_2(x - 2)$,

$g(x) = \log_3(x - 3)$

$\Rightarrow (f \circ g)^{-1}(1) = ?$

- A) 27 B) 36 C) 54 D) 81 E) 84

YÖS

3

$$20. \begin{cases} z_1 = 3 + 3i \\ z_2 = i \end{cases} \Rightarrow \arg\left(\frac{z_2}{z_1}\right) = ?$$

- A) $\frac{\pi}{6}$ B) $\frac{\pi}{4}$ C) $\frac{\pi}{3}$ D) $\frac{\pi}{2}$ E) π

$$22. \tan\left(\operatorname{arccot} \frac{\sqrt{3}}{3}\right) = ?$$

- A) 1 B) $\sqrt{3}$ C) $\frac{\sqrt{3}}{3}$ D) $\frac{\pi}{3}$ E) $\frac{3}{\pi}$

K
U
A
R
K
Y
A
Y
I
N
L
A
R
I

$$23. x \in \left(0, \frac{\pi}{2}\right),$$

$$\frac{7}{\sin x} = \frac{24}{\cos x} \Rightarrow \cos x = ?$$

- A) $\frac{7}{12}$ B) $\frac{7}{24}$ C) $\frac{24}{7}$ D) $\frac{24}{25}$ E) $\frac{7}{25}$

K
U
A
R
K
P
U
B
L
I
C
A
T
I
O
N
S

$$21. \begin{cases} z_1 = 3\operatorname{cis} \frac{\pi}{18} \\ z_2 = 4\operatorname{cis} \frac{4\pi}{9} \end{cases} \Rightarrow z_1 \cdot z_2 = ?$$

- A) $-12i$ B) $-12 - 12i$ C) -12
D) $12i$ E) $12 - 12i$

$$24. \prod_{k=1}^{10} 2^x = x \Rightarrow \frac{x}{2} = ?$$

- A) 2 B) 4 C) 16 D) 2^5 E) 2^9

YÖS

3

25. $(a_{n^2}) = \left(\frac{4n^2}{n^2}\right) \Rightarrow \frac{a_{n-1}}{a_n} = ?$

- A) $\frac{n^2-2n+1}{n^2}$ B) $\frac{n^2}{n^2-2n+1}$ C) $\frac{4^{n-1}}{n}$
 D) $\frac{n-1}{n}$ E) $\frac{n}{4n-4}$

26. $\lim_{x \rightarrow \infty} (2^{x+1} \cdot 5^{-x-1}) = ?$

- A) $-\infty$ B) $\frac{2}{5}$ C) $\frac{5}{2}$ D) 0 E) ∞

27. $\lim_{x \rightarrow \infty} [e^{\ln(2x^3-x^2)} - \ln(x^3+x^2)] = ?$

- A) -2 B) e^{-2} C) 2 D) e^2 E) ∞

28. $f: \mathbb{R}^+ \rightarrow \mathbb{R}$

$$f(x^2) = 4x^3 + 2x^2 + 6$$

$$\Rightarrow f'(1) = ?$$

- A) 2 B) 4 C) 6 D) 8 E) 10

29. $y = 4e^{\sin 2x} \Rightarrow \left. \frac{dy}{dx} \right|_{x=0} = ?$

- A) $-8e$ B) $-4e$ C) 0 D) 8 E) $8e$

30. $\int \frac{\cos x}{\sin x - 1} dx = ?$

- A) $\ln |\cos x - 1| + C$ B) $\cot x + C$
 C) $\tan x + C$ D) $\ln |\sin x - 1| + C$
 E) $\ln |\sin x| + C$

K
U
A
R
K
Y
A
Y
I
N
L
A
R
IK
U
A
R
K
P
U
B
L
I
C
A
T
I
O
N
S

YÖS

3

31. $\int \frac{dx}{x^2+2x+1} = ?$

- A) $\ln|x^2+2x+1| + C$
 B) $\ln|x+1| + C$
 C) $2 \cdot \ln|x+1| + C$
 D) $\arctan(x+1) + C$
 E) $-\frac{1}{x+1} + C$

32. $\int_0^3 d(2x^2-4x+7) = ?$

- A) 2 B) 4 C) 6 D) 8 E) 10

33. $f: [-3, 5] \rightarrow \mathbb{R}$

$$\int_{-3}^1 f(x) dx + \int_3^5 f(x) dx = \int_3^1 f(x) dx + \int_5^{-3} f(x) dx + 16$$

$$\Rightarrow \int_{-3}^5 f(x) dx = ?$$

- A) 16 B) 8 C) 0 D) -8 E) -16

34. $A^{-1} = \begin{bmatrix} 2 & 5 \\ 3 & 7 \end{bmatrix} \Rightarrow A = ?$

- A) $\begin{bmatrix} -7 & 5 \\ 3 & -2 \end{bmatrix}$ B) $\begin{bmatrix} 2 & 5 \\ 3 & 7 \end{bmatrix}$ C) $\begin{bmatrix} -2 & -5 \\ -3 & -7 \end{bmatrix}$
 D) $\begin{bmatrix} -7 & -5 \\ -3 & -2 \end{bmatrix}$ E) $\begin{bmatrix} -7 & 5 \\ -3 & 2 \end{bmatrix}$

K
U
A
R
K
Y
A
Y
I
N
L
A
R
IK
U
A
R
K
P
U
B
L
I
C
A
T
I
O
N
S

35. $A = \begin{bmatrix} 1 & 3 \\ 2 & 2 \end{bmatrix}, B = \begin{bmatrix} -4 & -1 \\ 6 & -2 \end{bmatrix} \Rightarrow |A \cdot B| = ?$

- A) -56 B) -48 C) -24 D) -36 E) -64

YÖS

3

36, 37, 38 ve 39. sorularda I. gruptaki her bir harf, rakam veya şekil, II. gruptaki farklı birer harf, rakam veya şekil ile gösterilmiştir. Buna göre, soru işaretiyle belirtilen harfleri, rakamları veya şekilleri bulunuz. In questions 36, 37, 38 and 39 each letter, numeral or figure in group I stand for a different letter, numeral or figure in group II. Accordingly, find the letters, numerals or figures which the questions mark stands for.

36.

I.	II.
1 7 5 6	} O S A B A B S O A B O S S A O B O A B O
6 1 5 7	
5 1 7 5	
1 7 6 5	
5 6 1 7	

⇒ 6157 = ?

- A) OSAB B) ABSO C) ABOS
D) SAOB E) OABO

37.

I.	II.
T Ü R B E	} 3 8 6 0 5 3 7 1 9 2 3 8 6 8 1 3 8 9 0 1 3 4 6 9 2
T A B U R	
T A V U K	
T A V A R	
T Ö V B E	

⇒ TABUR = ?

- A) 38605 B) 37192 C) 38681
D) 38901 E) 34692

38.





I.	II.
▽ □ ★ ○ □	} 2 4 3 4 2 5 2 2 3 4 9 4 9 7 9 2 3 4 5 3 4 6 7 6 7
▽ ★ □ ★ ▽	
★ ● ■ ● ■	
○ ▽ ▽ □ ★	
▲ ★ ▲ ■ ▲	

⇒ ★ ● ■ ● ■ = ?

- A) 24342 B) 52234 C) 94979
D) 23453 E) 46767

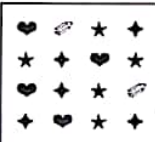
39.

I.	II.
T İ N B	} ?
N B T B	
T B N İ	
B T N B	

- A) 
- B) 
- C) 
- D) 
- E) 

YÖS

3

40. I. $x \blacksquare y = x^2 - y$

II. $x \blacktriangledown y = 2 \cdot x + 3 \cdot y$

III. $(3 \blacktriangledown 4) \blacksquare (2 \blacktriangledown 5) = ?$

Yukarıdaki eşitliklerde \blacksquare ve \blacktriangledown işaretlerinin görevleri verilmiştir. Buna göre, üçüncü eşitlikteki soru işaretinin yerine aşağıdaki sayılardan hangisi gelmelidir?

In the equations above, the functions of \blacksquare and \blacktriangledown are given. Accordingly, which of the following numbers does the question mark stand for in the third equation?

- A) 6 B) 78 C) 149 D) 246 E) 305

41. I. $(x - 1) \blacktriangle \frac{y}{2} = x + y^2$

II. $\sqrt{x} \square y^2 = (x - y) + 5$

III. $(4 \square 9) \blacktriangle 3 = ?$

Yukarıdaki eşitliklerde \blacktriangle ve \square işaretlerinin görevleri verilmiştir. Buna göre, üçüncü eşitlikteki soru işaretinin yerine aşağıdaki sayılardan hangisi gelmelidir?

In the equations above, the functions of \blacktriangle and \square are given. Accordingly, which of the following numbers does the question mark stand for in the third equation?

- A) 51 B) 52 C) 53 D) 54 E) 55

42. I. $a^4 \# b = a + 3b$

II. $a \bullet b = a + b^2 + 2$

III. $a \blacktriangle b^2 = a + b$

IV. $(81 \# 4) \blacktriangle (9 \bullet 5) = ?$

Yukarıdaki eşitliklerde $\#$, \bullet ve \blacktriangle işaretlerinin görevleri verilmiştir. Buna göre, dördüncü eşitlikteki soru işaretinin yerine aşağıdaki sayılardan hangisi gelmelidir?

In the equations above, the functions of $\#$, \bullet and \blacktriangle are given. Accordingly, which of the following numbers does the question mark stand for in the fourth equation?

- A) 20 B) 21 C) 22 D) 23 E) 24

43. I. $7 \bullet 2 = 15$

II. $5 \bullet 4 = 21$

III. $3 \bullet 6 = 27$

IV. $2 \bullet 8 = ?$

Yukarıdaki eşitliklerde \bullet işaretinin görevi verilmiştir. Buna göre, dördüncü eşitlikteki soru işaretinin yerine aşağıdaki sayılardan hangisi gelmelidir?

In the equations above, the function of \bullet is given. Accordingly, which of the following numbers does the question mark stand for in the fourth equation?

- A) 28 B) 30 C) 32 D) 34 E) 36

K
U
A
R
K
Y
A
Y
I
N
L
A
R
IK
U
A
R
K
P
U
B
L
I
C
A
T
I
O
N
S

YÖS

3

44.

+	a	b	c
a		2c	b+2
b			14
c			

$$\Rightarrow a = ?$$

Yukarıdaki toplama tablosunda a, b ve c harfleri pozitif birer tam sayının yerine kullanılmıştır. Buna göre, a kaçtır?

In the summation table above, the letters a, b and c each stands for a positive integer. Accordingly, what is the value of a?

- A) 2 B) 4 C) 6 D) 8 E) 10

45.

x	a	b	c
a		27	
b			$2 \cdot a^3$
c	2·b		

$$\Rightarrow a + b + c = ?$$

Yukarıdaki çarpma tablosunda a, b ve c harfleri pozitif birer tam sayının yerine kullanılmıştır. Buna göre, a + b + c kaçtır?

In the multiplication table above, the letters a, b and c each stands for a positive integer. Accordingly, what is the value of a + b + c?

- A) 12 B) 14 C) 16 D) 18 E) 20

46.

+	a	b	c	x	a	b	c
a		c-5	2·b	a		75	
b				b			
c				c			

$$\Rightarrow b = ?$$

Yukarıdaki toplama ve çarpma tablolarında a, b ve c harfleri pozitif birer tam sayının yerine kullanılmıştır. Buna göre, b kaçtır?

In the summation and multiplication tables above, the letters a, b and c each stands for a positive integer. Accordingly, what is the value of b?

- A) 5 B) 10 C) 15 D) 20 E) 25

47.

⊗	4	7	5
3	5		7
6		?	
8	20		27

Yukarıdaki tablodaki soru işaretinin yerine, aşağıdaki sayılardan hangisi gelmelidir?

Which of the following numbers does the question mark stand for in the table above?

- A) 25 B) 27 C) 29 D) 31 E) 33

K U A R K Y A Y I N L A R I

K U A R K P U B L I C A T I O N S

YÖS

3

48.

□	○	★	▲	●	■
○	★	○	▲	●	M
★	○	●	○	N	○
▲	▲	○	■	▲	■
●	L	■	▲	○	★
■	★	K	■	★	▲

$$\Rightarrow (M \square K) \square (N \square L) = ?$$

Yukarıdaki tablo □ işlemine göre düzenlenmiştir.

Buna göre, $(M \square K) \square (N \square L)$ nedir?

The table above is organized according to the □ operation. Accordingly, what is the value of $(M \square K) \square (N \square L)$?

- A) ○ B) ● C) ★ D) ■ E) ▲

49.

■	○	★	+	■
★	▲	▲	○	+
★	○	■	★	+
▲	★	■	○	★

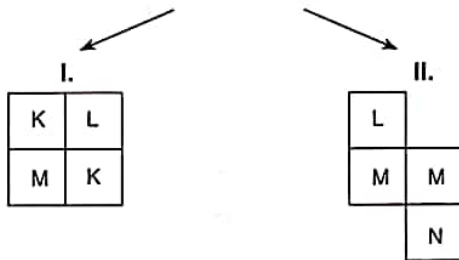

$$\Rightarrow N = ?$$

I ve II yukarıdaki tablonun farklı birer parçasıdır.

Buna göre, N aşağıdakilerden hangisidir?

I and II are different parts of the table above. Accordingly,

which of the following does N stand for?

- A) ○ B) ▲ C) ★ D) ■ E) +

50.

△	■	○	●	○	○	□	△	▲	▲	■	
△	●	●	■	○	△	○	○	●	□	▲	M
□	■	□	△	○	K	■	▲	▲	□	▲	●
○	▲	▲	▲	■	▲	●	○	□	△	L	

$$\Rightarrow K = ?; L = ?; M = ?$$

Yukarıdaki tabloya göre K, L ve M aşağıdakilerden hangisidir?

According to the table above, which of the following stands for K, L and M?

- | | K | L | M |
|----|-------|-------|-------|
| A) | ■ □ ▲ | ● ■ ○ | △ ▲ ■ |
| B) | ■ ○ ● | □ ▲ ■ | △ ■ □ |
| C) | △ □ ■ | ○ □ ▲ | ■ ● △ |
| D) | ● △ □ | ● ○ ■ | ▲ ○ ● |
| E) | ■ ● ○ | ○ ● ■ | △ ▲ ■ |

51.

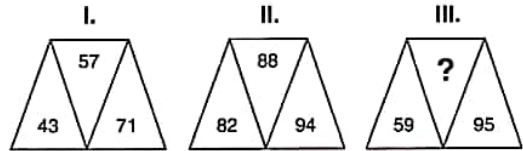

I. ve II. şekillerde verilen kurala göre, III. şekildeki soru işaretinin yerine aşağıdaki sayılardan hangisi gelmelidir?

Which of the following numbers does the question mark stand for in figure III, in accordance with the rule established in figures I and II?

- A) 55 B) 65 C) 77 D) 81 E) 89

K U A R K Y A Y I N L A R I

K U A R K P U B L I C A T I O N S

YÖS

3

52.

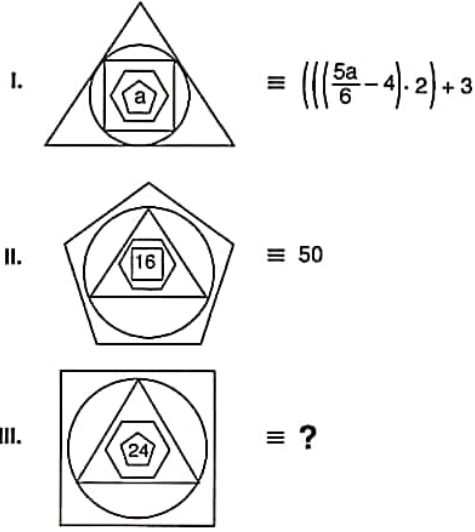

- A) 42 B) 46 C) 50 D) 54 E) 58

53.

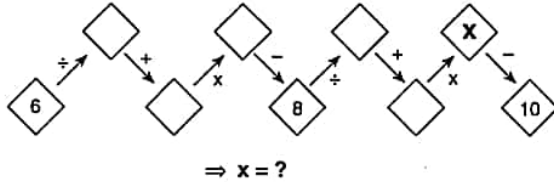

Yukarıdaki sayı-şekil dizisine göre x kaçtır?
What is the value of x, according to the number-figure sequence above?

- A) 14 B) 12 C) 7 D) 6 E) 4

54.

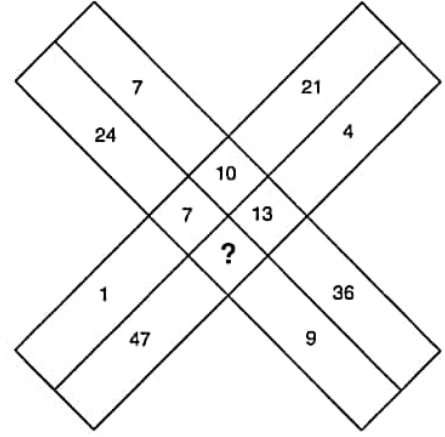

Yukarıdaki sayı-şekil ilişkisine göre soru işaretinin yerine aşağıdaki sayılardan hangisi gelmelidir?
Which of the following numbers does the question mark stand for, according to the number-figure relation above?

- A) 18 B) 19 C) 20 D) 21 E) 22

55.

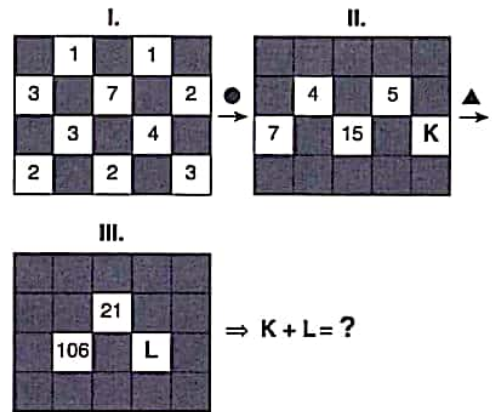

Yukarıdaki sayı-şekil dizisine göre K + L kaçtır?
What is the value of K + L, according to the number-figure sequence above?

- A) 110 B) 111 C) 112 D) 113 E) 114

YÖS

3

56 ve 57. sorularda farklı olan şekli bulunuz.
Find the different figure in questions 56 and 57.

56.

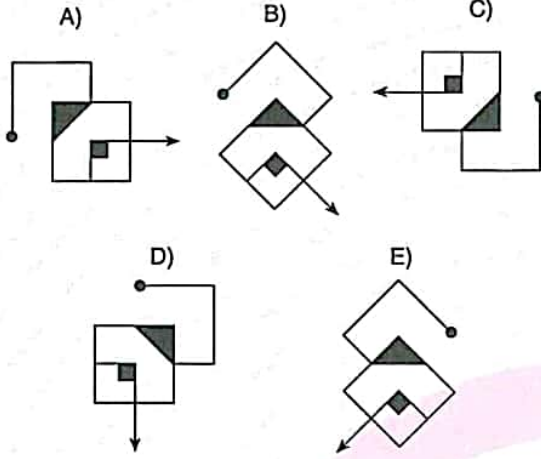

57.

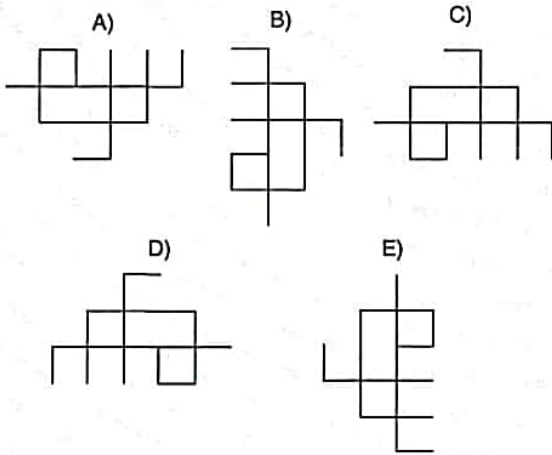

58.

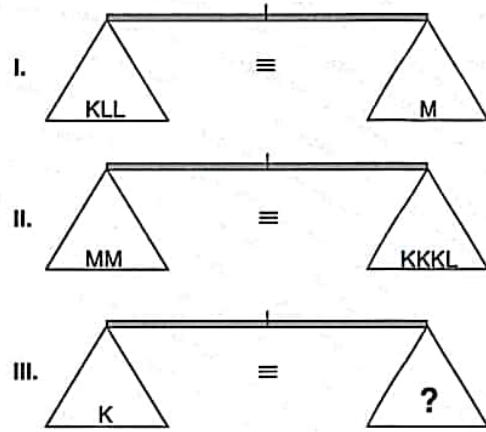

Yukarıdaki terazilerin üçü de dengededir. Buna göre, III. terazideki soru işaretini aşağıdakilerden hangisi göstermektedir?

All three scales above are in balance. Accordingly, which of the following does the question mark stand for in the third scale?

- A) L B) LL C) LLL
D) LLLL E) LLLLL

59.

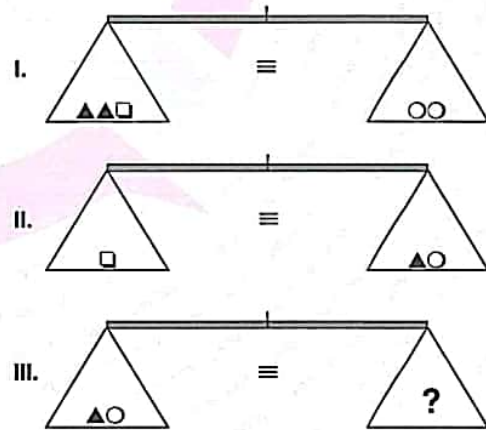

Yukarıdaki terazilerin üçü de dengededir. Buna göre, III. terazideki soru işaretini aşağıdakilerden hangisi göstermektedir?

All three scales above are in balance. Accordingly, which of the following does the question mark stand for in the third scale?

- A) □ ○ B) ▲ ▲ ▲ C) ▲ ○ ○
D) ▲ ▲ ▲ ▲ E) □ □

K U A R K Y A Y I N L A R I

K U A R K P U B L I C A T I O N S

YÖS

3

60, 61 ve 62. sorularda, verilen her bir şekil matrisindeki soru işaretinin yerine hangi şeklin getirilmesi gerektiğini bulunuz.

In questions 60, 61 and 62, find the figure which should replace the question mark in each given figure matrix.

60.

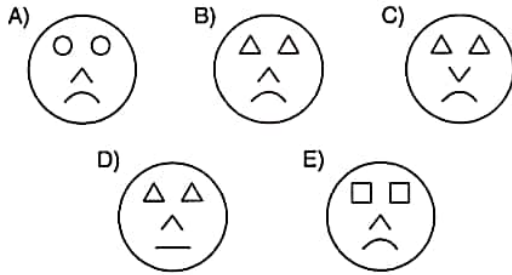
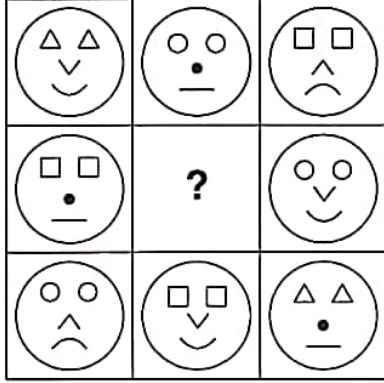

61.

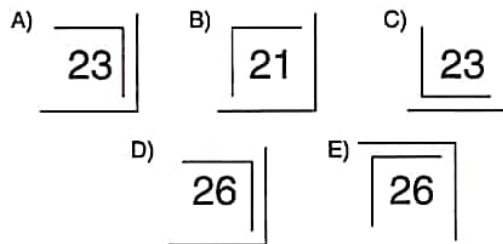
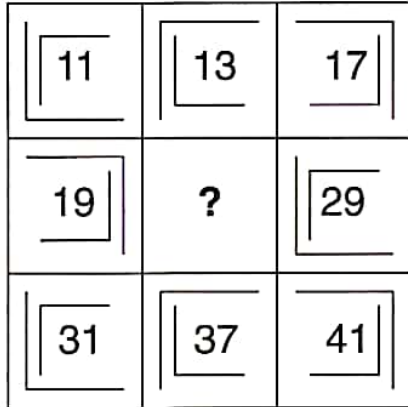

62.

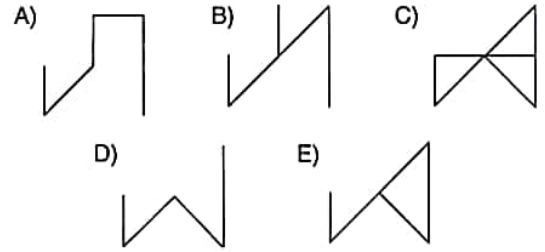
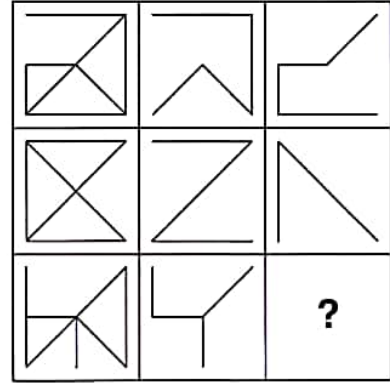

63.

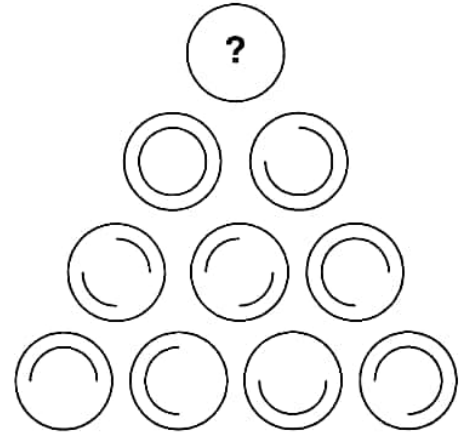

Yukarıdaki şekilde soru işaretinin yerine hangi şeklin getirilmesi gerektiğini bulunuz.

In the figure above, find the figure which the question mark stands for.

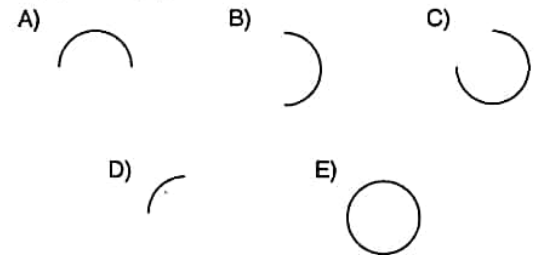

K U A R K Y A Y I N L A R I

K U A R K P U B L I C A T I O N S

YÖS

3

64, 65, 66, 67, 68 ve 69. sorularda, I. satırda belirlenen ilişkiye göre II. satırı hangi şeklin tamamladığını bulunuz.

In questions 64, 65, 66, 67, 68 and 69, find the figure which completes row II, in accordance with the relation established in row I.

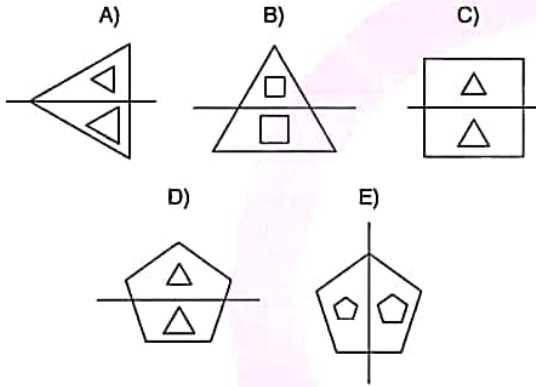
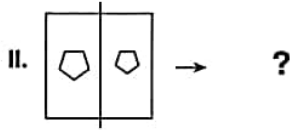
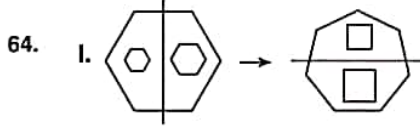

65.

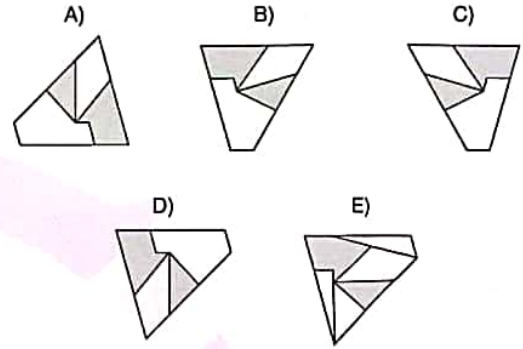
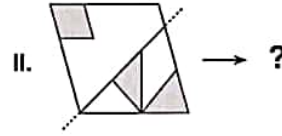
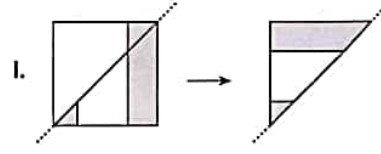

K U A R K Y A Y I N L A R I

K U A R K P U B L I C A T I O N S

YÖS

3

66.

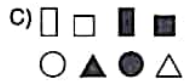
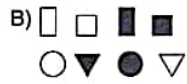

68.

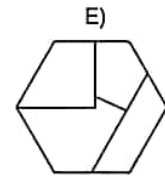
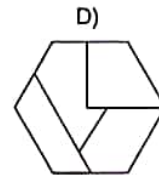
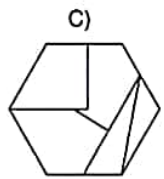
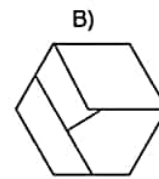
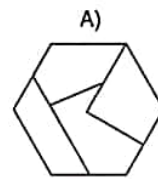
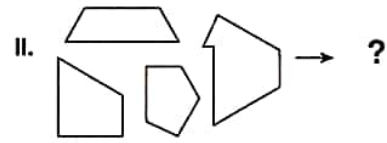
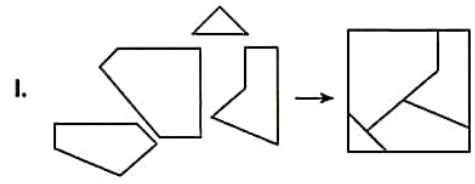

67.

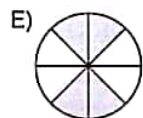
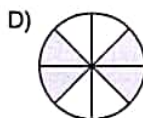
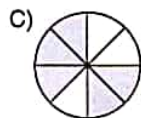
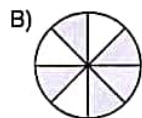
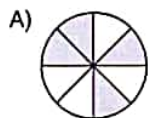
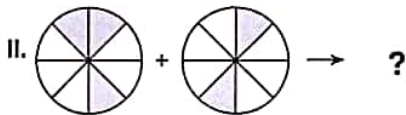
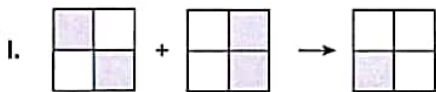

K U A R K Y A Y I N L A R I

K U A R K P U B L I C A T I O N S

YÖS

3

69.

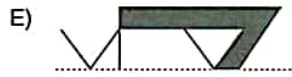
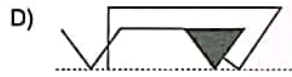
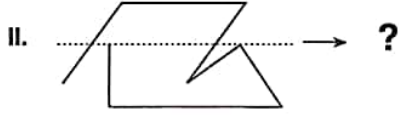
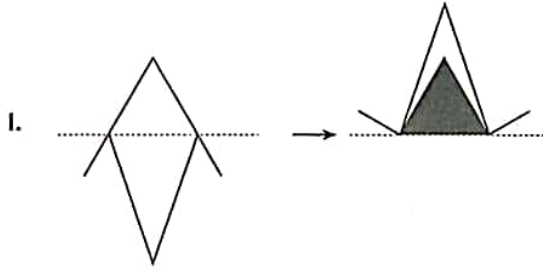

70, 71 ve 72. sorularda, verilen her bir şekil dizisindeki soru işaretinin yerine hangi şeklin getirilmesi gerektiğini bulunuz.

In questions 70, 71 and 72, find the figure which should replace the question mark in each given figure sequence.

70.

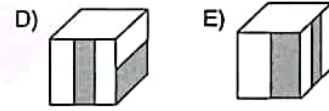
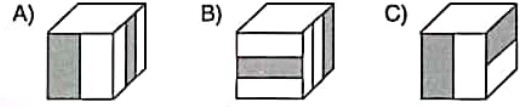
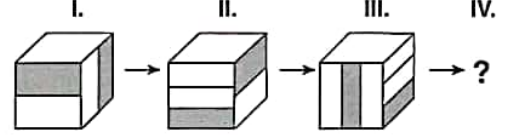

71.

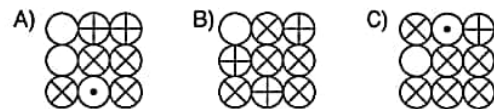
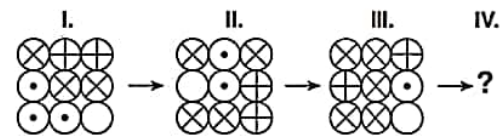

K U A R K Y A Y I N L A R I

K U A R K P U B L I C A T I O N S

YÖS

3

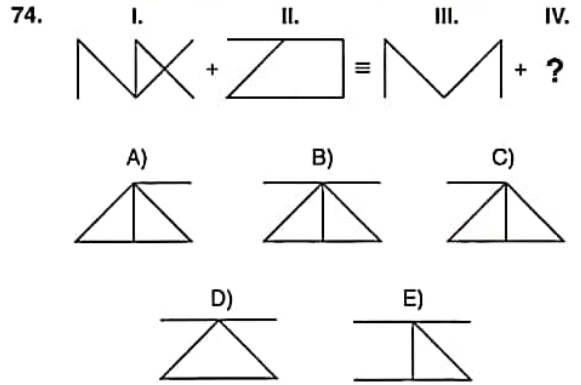
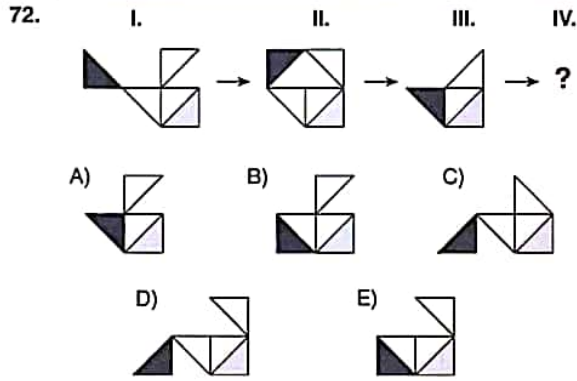

73 ve 74. sorularda, soru işaretinin yerine getirilmesi gereken şekli bulunuz.

In question 73 and 74, find the figure to replace the question mark.

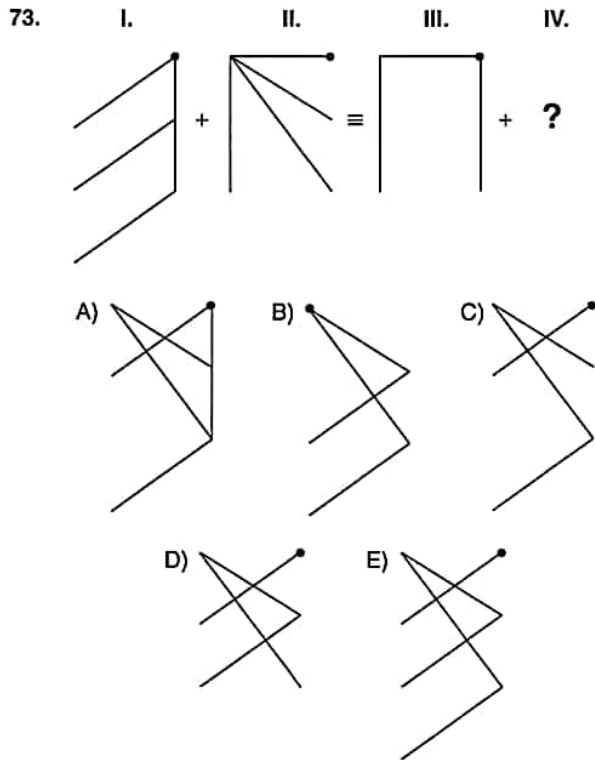

75.

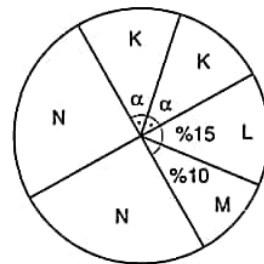

$$2K + L + M = 2N \Rightarrow N - L - M = \%?$$

Yukarıdaki dairesel grafikte verilen bilgilere göre, $N - L - M$ yüzde kaçtır?

According to the information in the circular chart above, what is the percentage of $N - L - M$?

- A) 0 B) 5 C) 10 D) 15 E) 20

YÖS

3

76.

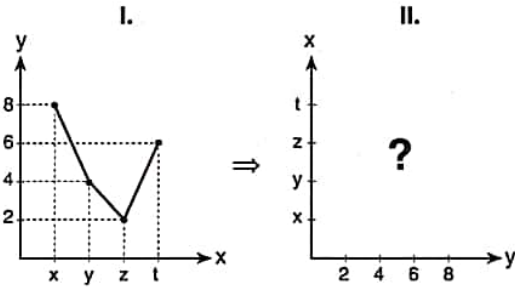

Yukarıdaki birinci çizgi grafikte verilen bilgilere göre, ikinci grafik aşağıdakilerden hangisidir?

According to the first line chart above, which of the following does the second chart stand for?

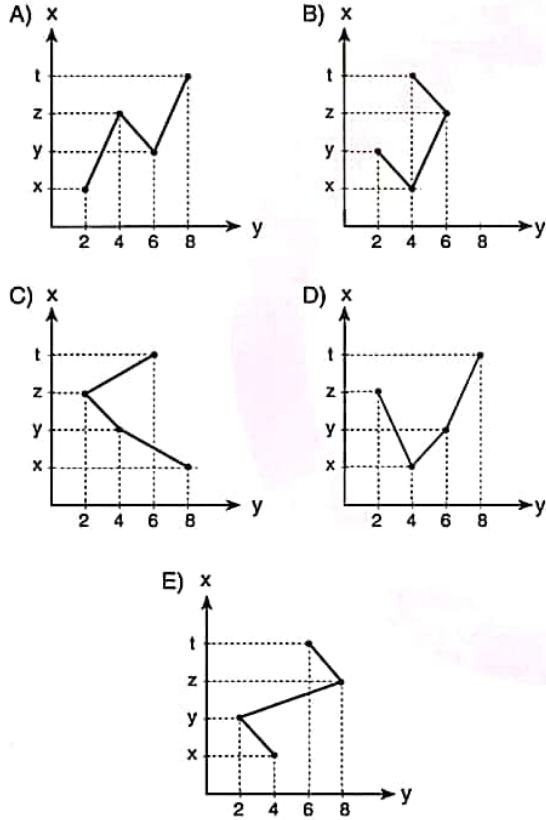

77 ve 78. soruları aşağıdaki örnekte verilen ilişkiye göre cevaplayınız.

Answer questions 77 and 78, in accordance with the relation established in the example below.

ÖRNEK / EXAMPLE:

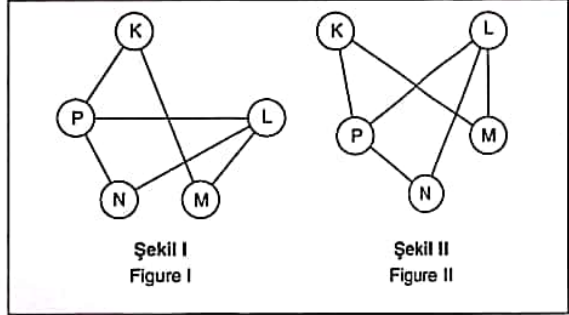

K, L, M, N ve P harfleri I. şekildeki gibi birbirine bağlanmıştır. I. şekildeki bağlantı sayıları ve birbirine bağlanan harfler değişmemek koşuluyla II. şekil elde edilmiştir.

The letters K, L, M, N and P are linked as in figure I. figure II has been constructed so as not to change the number of links and the letters that are linked each other in figure I.

77.

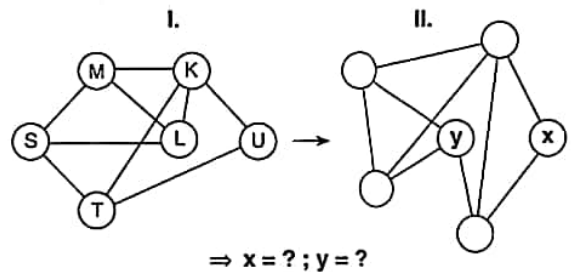

A) S; M

B) U; S

C) U; T

D) S; T

E) U; M

YÖS

3

78.

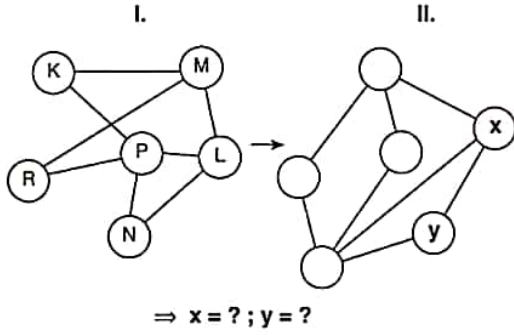

- A) M; P B) L; N C) N; M
D) M; R E) P; L

79.

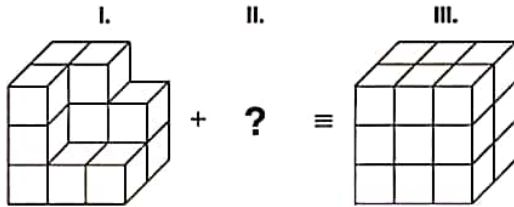

Yukarıdaki birinci satırdaki cisim aşağıdakilerden hangisiyle tamamlanırsa üçüncü satırdaki cisim elde edilir?

Which of the following shapes completes the shape in row I to the shape in row III?

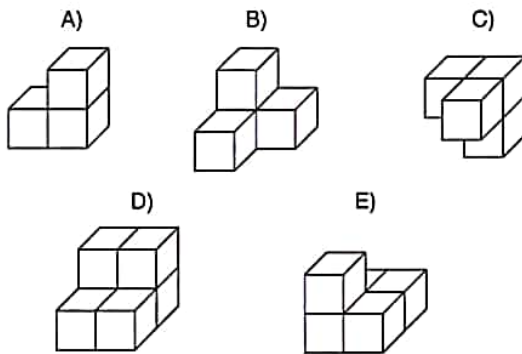

80.

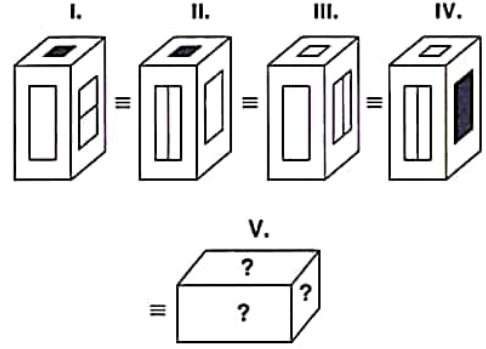

Yukarıdaki şekillerin tümü aynı nesneyi göstermektedir. Buna göre, aşağıdakilerden hangisi bu nesnenin başka bir görünümüdür?

The figures above all represent the same object. Accordingly, which of the following is another view of the same object?

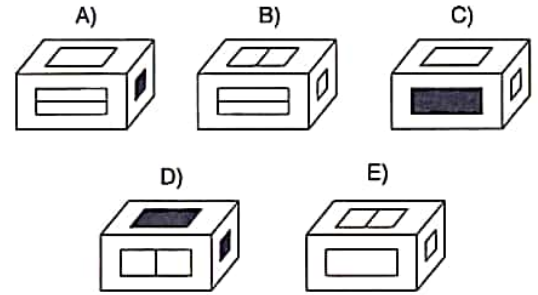

1. $5 + 7 + 9 + \dots + 21 = A$,
 $4 + 6 + 8 + \dots + 20 = B$
 $\Rightarrow A - B = ?$
 A) 6 B) 7 C) 9 D) 10 E) 12

2. $x \in \mathbb{Z}^+$, $A \in \mathbb{Z}$,

$$\frac{2x+20}{x+4} = A \Rightarrow \sum A = ?$$

- A) 7 B) 10 C) 12 D) 16 E) 20

3. $x, y, z \in \mathbb{Z}^+$,
 $y(x+z) = 23$
 $\Rightarrow x + y + z = ?$

- A) 19 B) 22 C) 23 D) 24 E) 25

4. $A = 3x + 3 = 4y + 3 = 6z + 3$

$$100 < A < 120 \Rightarrow A = ?$$





- A) 101 B) 104 C) 107 D) 111 E) 119

K U A R K Y A Y I N L A R I

K U A R K P U B L İ C A T İ O N S

- 5.

ELMA SATIŞI / APPLE SALES

X	
Y	
Z	 

 : n kasa elma / n boxes of apple

Yukarıdaki grafik bir markette X, Y, Z türündeki 3 elmanın satış grafiğidir. Bu markette X türündeki elmadan Y türündeki elmaya göre 200 kasa daha fazla satıldığına göre, Z türündeki elmadan kaç kasa satılmıştır?

The pictograph above shows the number of boxes of three types of apples X, Y, and Z that were sold in a supermarket. If 200 more boxes of type X apples than type Y apples were sold in that supermarket, how many boxes of type Z apples were sold?

- A) 80 B) 200 C) 250 D) 400 E) 500

YÖS

4

6. $\left(-1 - \frac{1}{2} + \frac{1}{3}\right) - \left(1 - \frac{1}{2} - \frac{1}{3}\right) = ?$

- A) $-\frac{4}{3}$ B) -1 C) 0 D) 1 E) $\frac{4}{3}$

7. $A = \frac{18}{x^2 + 4x + 7} \Rightarrow \max(A) = ?$

- A) 2 B) 4 C) 6 D) 8 E) 10

8. $\frac{x^3 + \frac{3x^2}{y} + \frac{3x}{y^2} + \frac{1}{y^3}}{(xy + 1) \cdot y^{-1}} = ?$

- A) $xy + 1$ B) $xy^2 + y$ C) $x + \frac{1}{y}$
D) $\left(x + \frac{1}{y}\right)^2$ E) $\frac{1}{x} + y$

9. $5^{1.456} = x \Rightarrow 5^{0.456} = ?$

- A) x^{-1} B) $5 - x$ C) $5x$ D) $x + 1$ E) $\frac{x}{5}$

10. $\frac{m^{2k} - n^{2t}}{m^k + n^t} + n^t = ?$

- A) $-m^k$ B) $-n^t$ C) 0 D) n^t E) m^k

11. $\left[\frac{x - \sqrt{xy}}{x - y}\right] \cdot (\sqrt{x} + \sqrt{y}) = ?$

- A) $-\sqrt{x}$ B) $-\sqrt{y}$ C) \sqrt{x}
D) $\sqrt{x} - \sqrt{y}$ E) $\sqrt{x} + \sqrt{y}$

K
U
A
R
K
Y
A
Y
I
N
L
A
R
IK
U
A
R
K
P
U
B
L
I
C
A
T
I
O
N
S

YÖS

4

12. $A \not\subset B$, $A \cap B \neq \emptyset$,
 $n(A) = 12$, $n(B) = 16$
 $\Rightarrow \max(n(A \cup B)) + \min(n(A \cup B)) = ?$
 A) 40 B) 41 C) 42 D) 43 E) 44

13. $\frac{a}{b} = \frac{x}{y} = 2 \Rightarrow \frac{a \cdot c + x \cdot (-z)}{b - y} = ?$
 A) -2 B) $-\frac{1}{2}$ C) 0 D) $\frac{1}{3}$ E) 2

14. $f(x) = x + 2$
 $\Rightarrow f(x + y) - (f(x) + f(y)) = ?$
 A) -4 B) -2 C) 0
 D) $2x + 2y - 2$ E) 2

15. $f(x) = \frac{x-1}{2} \Rightarrow \text{Grafik(Grahp)}(f^{-1}(x)) = ?$

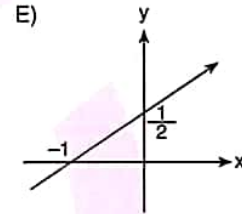
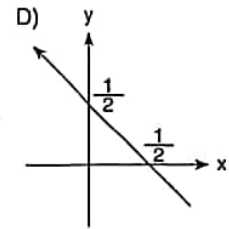
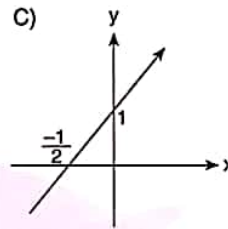
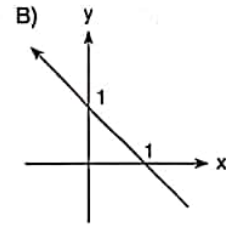
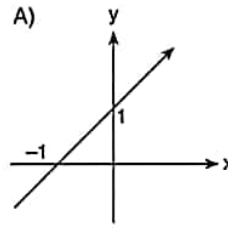

16. $|x-2| + |2-x| + 4 = 2 \Rightarrow \text{ÇK(SS)} = ?$
 A) $\{-2, 2\}$ B) $\{2, 4\}$ C) $\{-2, 4\}$
 D) $\{-4, 2\}$ E) \emptyset

K U A R K Y A Y I N L A R I

K U A R K P U B L I C A T I O N S

YÖS

4

17. $f(x) = x^2 - 4x - 2,$

$f(x_1) = f(x_2) = 0$

$\Rightarrow x_1 \cdot x_2 - x_1 - x_2 = ?$

- A) -8 B) -6 C) -4 D) 2 E) 4

19. $\sum_{k=1}^5 k^2 + \sum_{k=1}^5 2k + \sum_{k=1}^5 1 = ?$

- A) 140 B) 130 C) 110 D) 100 E) 90

K
U
A
R
K
Y
A
Y
I
N
L
A
R
I

20. $\left. \begin{array}{l} \log 2 = a \\ \log 3 = b \end{array} \right\} \Rightarrow \log 600 = ?$

- A) a.b B)
- $\frac{a}{b}$
- C) 2a+b
-
- D) a+b+2 E) a+b+1

18.

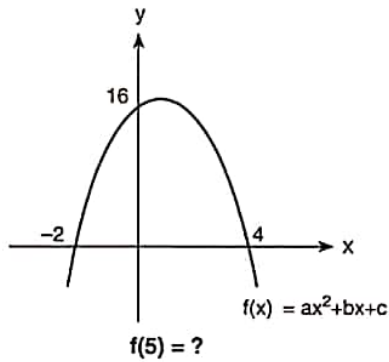

- A) -14 B) -12 C) -10 D) -8 E) -6

K
U
A
R
K
P
U
B
L
I
C
A
T
I
O
N
S

21. $z_1 = -3 - 4i,$
 $z_2 = 4 + 3i$
 $\Rightarrow z = \frac{z_1}{z_2} \Rightarrow |\bar{z}| = ?$

- A) -1 B) 0 C) 1 D) 5 E)
- $\frac{1}{5}$

YÖS

4

22. $f(x) = \sin x - \tan x \Rightarrow f(1830^\circ) = ?$

- A) $-\frac{\sqrt{3}}{2}$ B) $\frac{3-2\sqrt{3}}{6}$ C) $\frac{\sqrt{3}+2}{3}$
 D) $\frac{2-\sqrt{3}}{2}$ E) $\frac{\sqrt{3}+1}{6}$

25. $f(x) = x^4 - x^3$

$$\Rightarrow \lim_{x \rightarrow 2} \frac{f(x) - f(2)}{2 - x} = ?$$

- A) -20 B) -18 C) -16 D) -14 E) -12

K
U
A
R
K
Y
A
Y
I
N
L
A
R
I

23. $\lim_{x \rightarrow 0} \left(\frac{\sin 2x}{x} + \frac{\tan 2x}{x} \right) = ?$

- A) 1 B) 2 C) 3 D) 4 E) 5

K
U
A
R
K
P
U
B
L
I
C
A
T
I
O
N
S

24. $\lim_{x \rightarrow \frac{\pi}{4}} \frac{1 + \tan x}{\sqrt{2} \cdot \cos x} = ?$

- A) 1 B) $\sqrt{3}$ C) 2 D) $\frac{2\sqrt{3}}{3}$ E) 3

26.

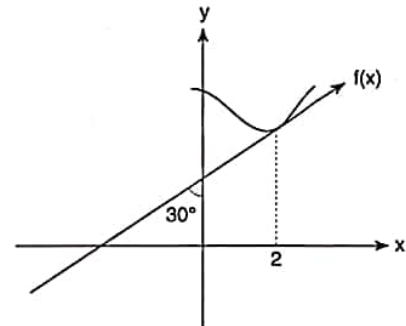
 $f'(2) = ?$

- A) $-\frac{\sqrt{3}}{2}$ B) $-\sqrt{3}$ C) 1 D) $\frac{\sqrt{3}}{2}$ E) $\sqrt{3}$

YÖS

4

27. $\int \sin x \, d(\sin x) = ?$

- A) $\frac{-\sin 2x}{2} + C$ B) $\frac{\cos 2x}{4} + C$ C) $\frac{\sin^2 x}{2} + C$
 D) $\frac{-\cos^2 x}{2} + C$ E) $\frac{\sin 2x}{4} + C$

28. $\int_{-1}^0 \frac{5x^4 - 3x^2}{x^5 - x^3 + 1} dx = ?$

- A) -2 B) -1 C) 0 D) 1 E) 2

29. $\begin{bmatrix} 1 & -1 & 4 \\ 3 & -2 & -5 \end{bmatrix} = a_{12} + a_{23} - a_{13} = ?$

- A) -8 B) -9 C) -10 D) -11 E) -12

30. $A = \begin{bmatrix} 2 & 0 & -3 \end{bmatrix}, B = \begin{bmatrix} 1 \\ 0 \\ -4 \end{bmatrix} \Rightarrow A \cdot B = ?$

- A) [14] B) [2 0 12] C) $\begin{bmatrix} 2 \\ 0 \\ 12 \end{bmatrix}$
 D) $\begin{bmatrix} 2 & 1 \\ 0 & 0 \\ -3 & -4 \end{bmatrix}$ E) [16]

K
U
A
R
K
Y
A
Y
I
N
L
A
R
IK
U
A
R
K
P
U
B
L
I
C
A
T
I
O
N
S

31. $[BA \parallel EF,$
 $m(\widehat{ABC}) = 40^\circ,$
 $m(\widehat{BCD}) = 50^\circ,$
 $m(\widehat{DEF}) = 35^\circ$
 $\Rightarrow \alpha = ?$

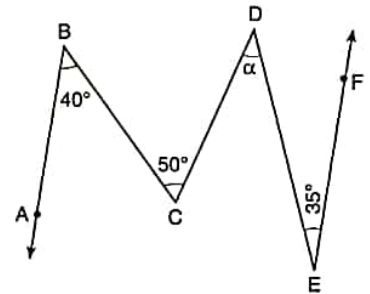

- A) 30° B) 35° C) 40° D) 45° E) 50°

YÖS

4

32. $[DE] \parallel [BC]$,
 $[DF] \parallel [AB]$,
 $IAEI = 3 \text{ cm}$,
 $IEBI = 5 \text{ cm}$,
 $IBFI = 4 \text{ cm}$
 $\Rightarrow IFCI = x = ? \text{ cm}$

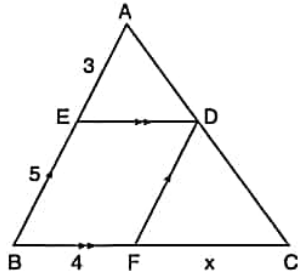

- A) 13 B) $\frac{20}{3}$ C) 14 D) $\frac{43}{3}$ E) 15

34. O noktası şekildeki dairenin merkezidir.
 Point O is the center of the circle in the figure.

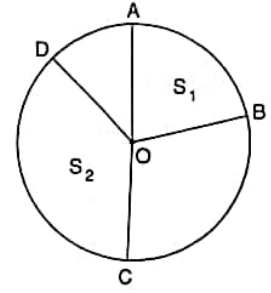

$$2 \cdot m(\widehat{AB}) = m(\widehat{DC})$$

$$\Rightarrow \frac{S_1}{S_2} = ?$$

- A) $\frac{1}{4}$ B) $\frac{1}{3}$ C) $\frac{1}{2}$ D) 1 E) 1,5

K U A R K Y A Y I N L A R I

K U A R K P U B L I C A T I O N S

33. $IAEI = 6 \text{ cm}$,
 $IEBI = 8 \text{ cm}$,
 $IBFI = IFCI$,
 $IDCI = 10 \text{ cm}$
 $\Rightarrow IADI = ? \text{ cm}$

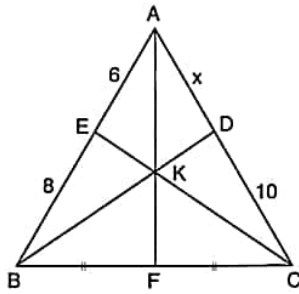

- A) 6 B) 7 C) 7,5 D) 8 E) 9,5

- 35.

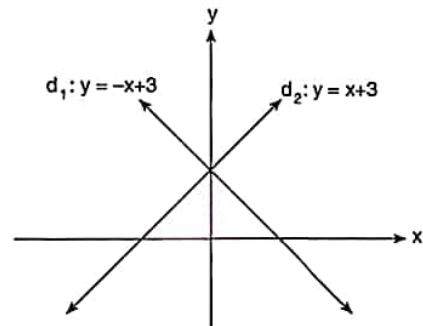

Taralı Alan / The Shaded Area = ? cm^2

- A) 3 B) 6 C) 9 D) 12 E) 15

YÖS

4

36. Yukarıdaki I. satırda verilen şekil, belirtilen eksenlerden adım adım katlanarak IV. satırdaki şekil elde ediliyor ve ardından işaretli bölgelerden kesiliyor. Buna göre, IV. satırdaki şekilde kesilen parçalar çıkartıldıktan sonra, şeklin konumu değiştirilmeden katlandığı eksenlerden açık hale getirilirse aşağıdaki şekillerden hangisi oluşur? Figure IV is formed by folding figure I step by step by the following axis and then cut by the marked areas. Accordingly, which of the following is formed when the pieces cut in figure IV are unfolded by the folded axis remaining their position after being removed?

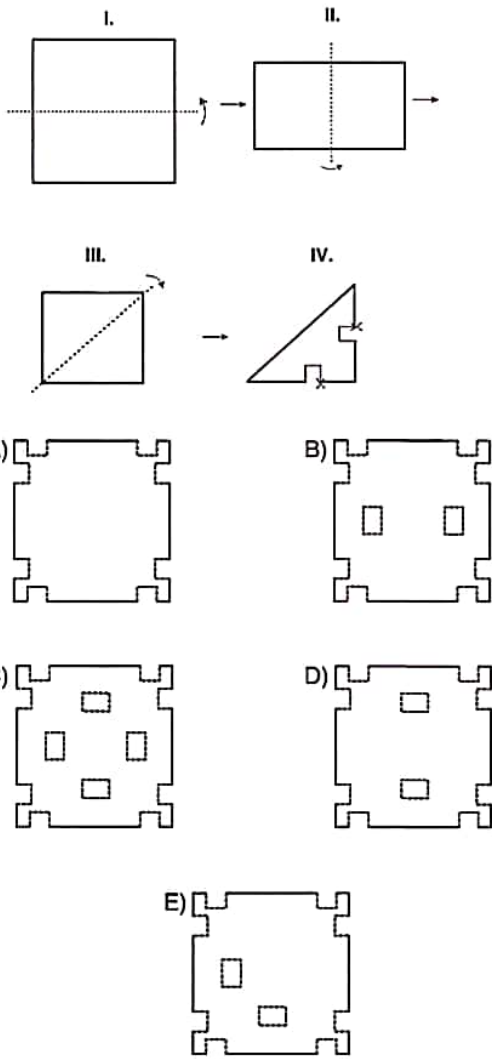

37.

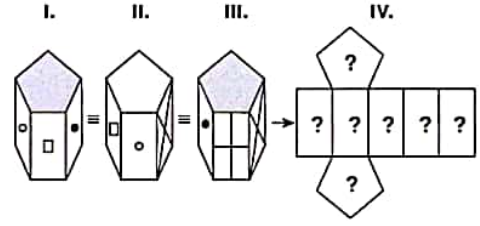

Yukarıdaki şekiller aynı nesneyi göstermektedir. Buna göre bu nesnenin açılmış hali aşağıdakilerden hangisidir?

The figures above represent the same object. Accordingly, which of the following represent the unfolded form of this object?

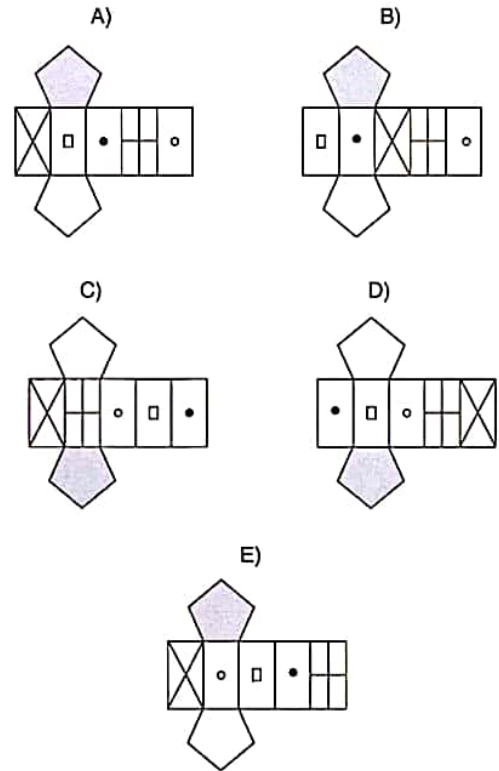

YÖS

4

38.

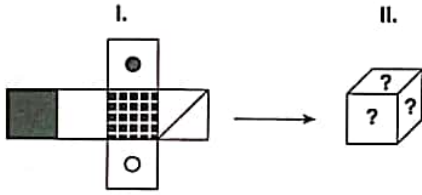

Aşağıdakilerden hangisi I. şekildeki küpün kapalı halidir?

Which of the following corresponds to the folded form of the figure in cube I above?

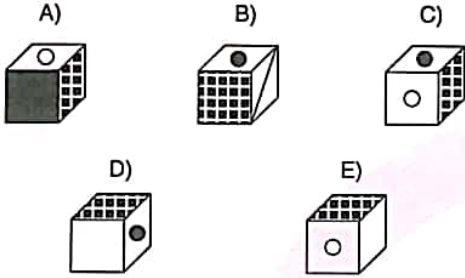

39. soruyu aşağıdaki örnekte verilen ilişkiye göre cevaplayınız.

Answer question 39, in accordance with the relation established in the example below.

ÖRNEK / EXAMPLE:

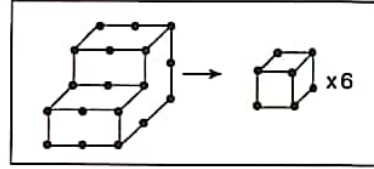

39.

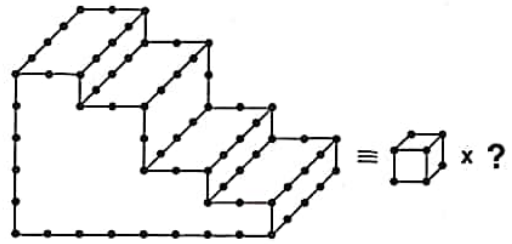

A) 90 B) 92 C) 94 D) 96 E) 98

YÖS

4

40 ve 41. soruları aşağıdaki örnekte verilen ilişkiye göre cevaplayınız.

Answer questions 40 and 41, in accordance with the relation established in the example below.

ÖRNEK / EXAMPLE:

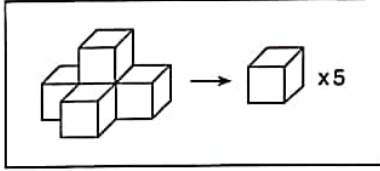

40.

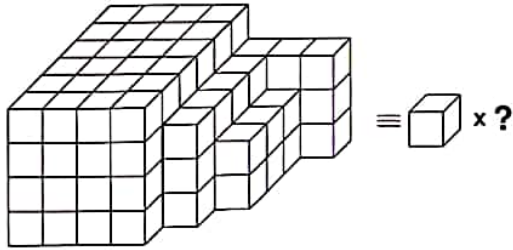

A) 121 B) 122 C) 123 D) 124 E) 125

41.

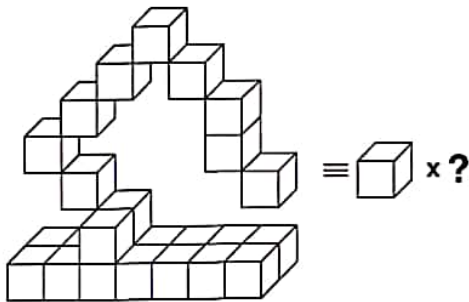

A) 24 B) 25 C) 26 D) 27 E) 28

42 ve 43. sorularda, soru işaretinin yerine getirilmesi gereken şekli bulunuz.

In question 42 and 43, find the figure to replace the question mark.

42. I. II. III. IV.

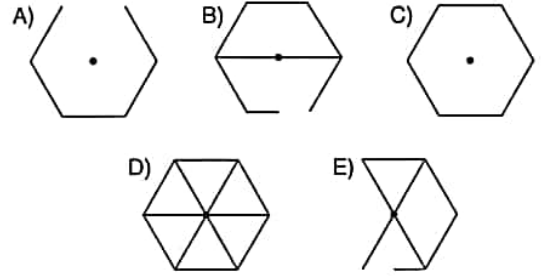
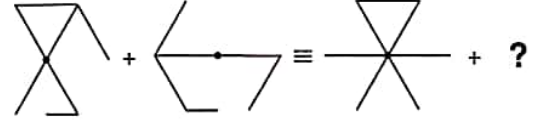

43. I. II. III. IV.

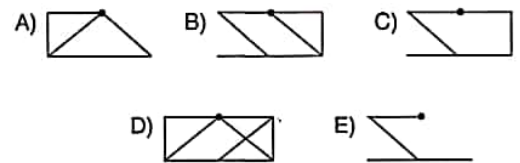
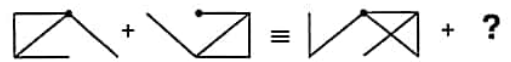

K U A R K Y A Y I N L A R I

K U A R K P U B L I C A T I O N S

YÖS

4

44 ve 45. sorularda, I. satırda belirlenen ilişkiye göre II. satırı hangi şeklin tamamladığını bulunuz.

In questions 44 and 45, find the figure which completes row II, in accordance with the relation in row I.

44.

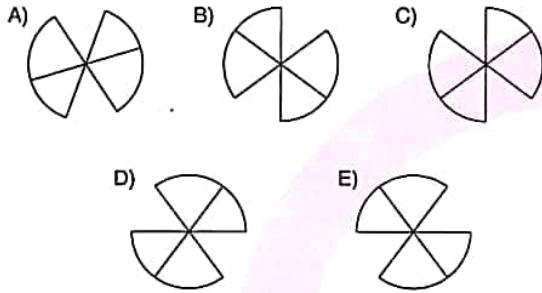
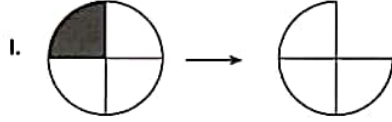

45.

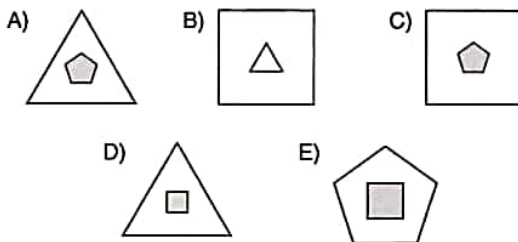

46, 47, 48 ve 49. sorularda, verilen her bir şekil dizisindeki soru işaretinin yerine hangi şeklin getirilmesi gerektiğini bulunuz.

In questions 46, 47, 48 and 49, find the figure which should replace the question mark in each given figure sequence.

46.

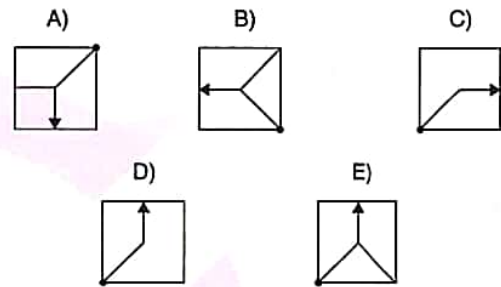
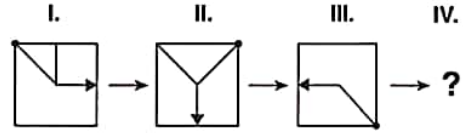

47.

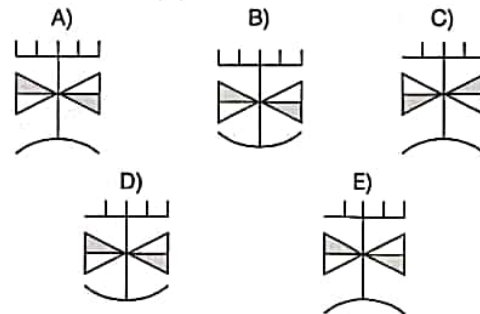
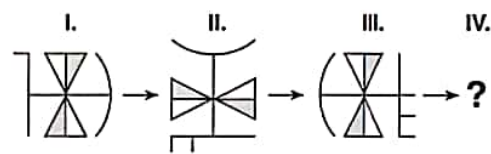

YÖS

4

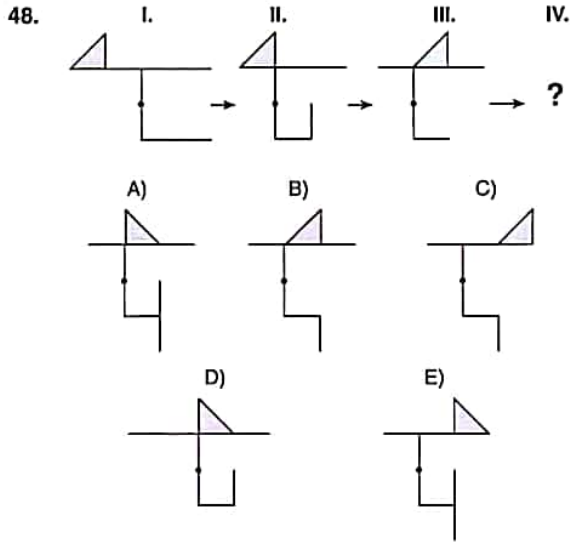

50, 51 ve 52. sorularda, verilen her bir şekil matrisindeki soru işaretinin yerine hangi şeklin getirilmesi gerektiğini bulunuz.

In questions 50, 51 and 52, find the figure which should replace the question mark in each given figure matrix.

50.

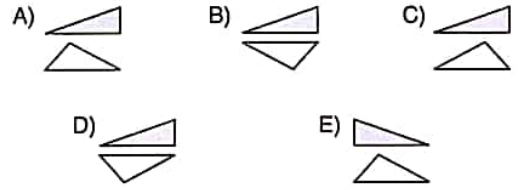
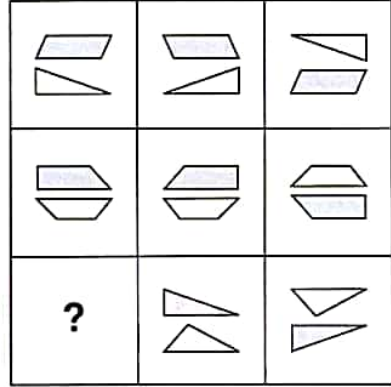

51.

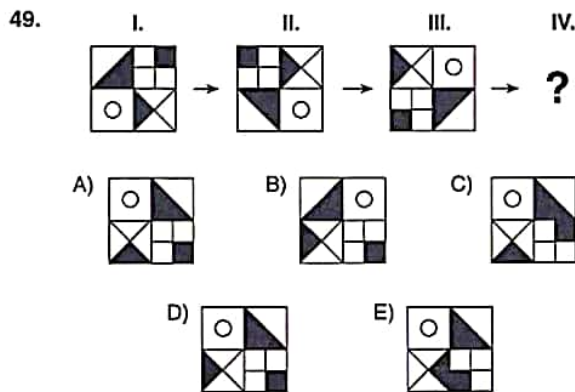
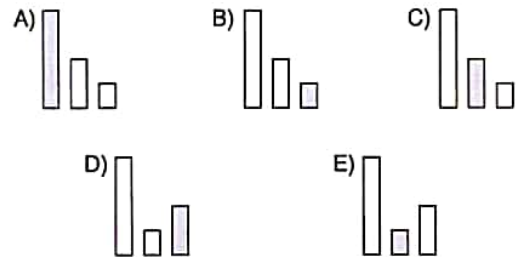
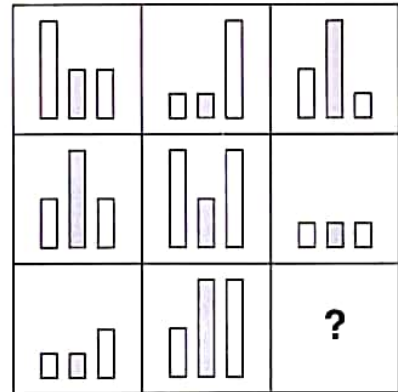

K U A R K Y A Y I N L A R I

K U A R K P U B L I C A T I O N S

YÖS

4

52.

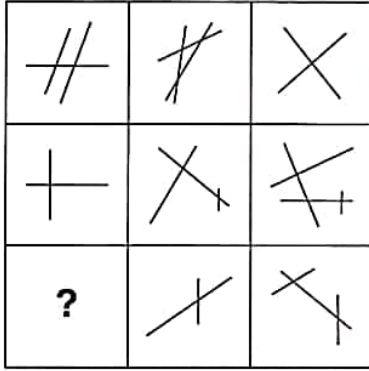

- A)
- B)
- C)
- D)
- E)

53 ve 54. soruları aşağıdaki örnekte verilen ilişkiye göre cevaplayınız.

Answer questions 53 and 54, in accordance with the relation established in the example below.

ÖRNEK / EXAMPLE:

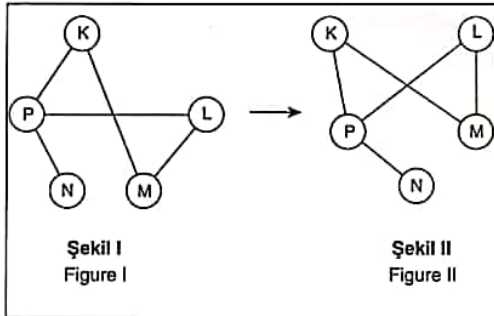

K, L, M, N ve P harfleri I. şekildeki gibi birbirine bağlanmıştır. I. şekildeki bağlantı sayıları ve birbirine bağlanan harfler değişmemek koşuluyla II. şekil elde edilmiştir.

The letters K, L, M, N and P are linked as in figure I. figure II has been constructed so as not to change the number of links and the letters that are linked to each other in figure I.

53.

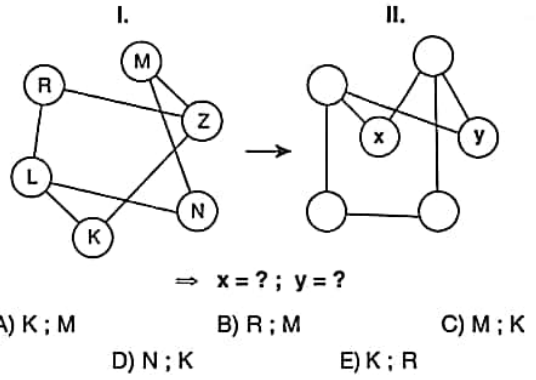

54.

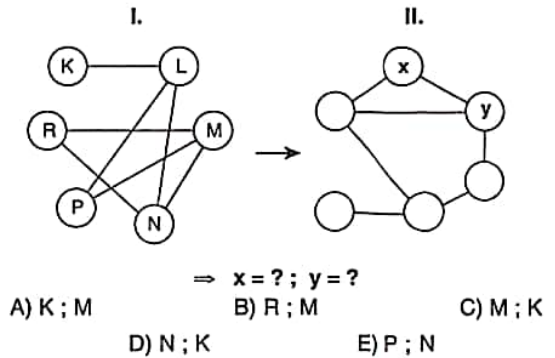

K U A R K Y A Y I N L A R I

K U A R K P U B L İ C A T İ O N S

YÖS

4

55.

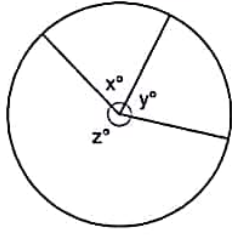

$$3x + 2y = 370^\circ, x + z = 280^\circ \Rightarrow x + y = ?$$

Yukarıdaki dairesel grafikte verilen bilgilere göre, $x + y$ kaçtır?

According to the information in the circular chart above, what is the value of $x + y$?

- A) 150° B) 160° C) 170° D) 180° E) 190°

56.

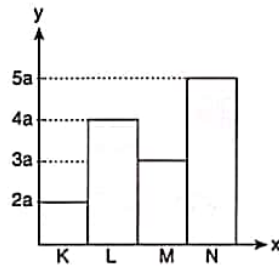

$$K + L + M + N = 560 \Rightarrow N + K = ?$$

Yukarıdaki sütun grafikte verilen bilgilere göre, $N + K$ kaçtır?

According to the information in the column chart above, what is the value of $N + K$?

- A) 180 B) 210 C) 240 D) 280 E) 300

57.

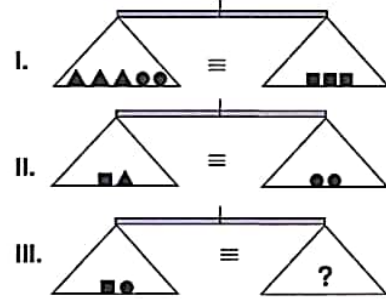

Yukarıdaki terazilerin üçü de dengededir. Buna göre, III. terazideki soru işaretini aşağıdakilerden hangisi göstermektedir?

All three scales above are in balance. Accordingly, which of the following does the question mark stand for in the third scale?

- A) $\blacktriangle\blacktriangle\bullet$ B) $\blacktriangle\bullet$ C) $\blacksquare\blacktriangle$
D) $\blacksquare\blacksquare$ E) $\blacktriangle\blacktriangle$

58.

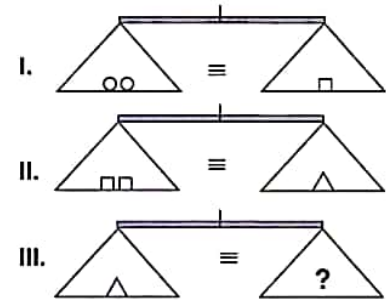

Yukarıdaki terazilerin üçü de dengededir. Buna göre, III. terazideki soru işaretini aşağıdakilerden hangisi göstermektedir?

All three scales above are in balance. Accordingly, which of the following does the question mark stand for in the third scale?

- A) $\circ\circ$ B) $\square\circ\circ$ C) $\circ\circ\circ$
D) $\circ\circ$ E) $\circ\circ\circ$

K U A R K Y A Y I N L A R I

K U A R K P U B L I C A T I O N S

YÖS

4

59.

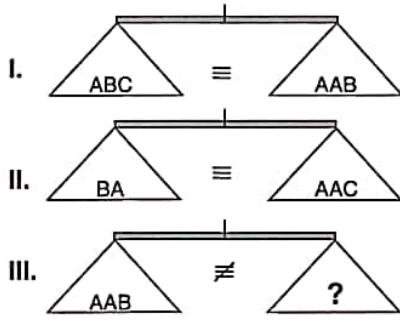



Yukarıdaki terazilerin ilk ikisi dengede olup, üçüncüsü dengede değildir. Buna göre, III. terazi-deki soru işaretini aşağıdakilerden hangisi göstermektedir?

First two scales above are in balance, the third scale is not in balance. Accordingly, which of the following does the question mark stand for in the third scale?

- A) BB B) CCB C) CCCC
D) AAC E) AACC

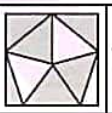
60.

			
I	4	K	4
II	L	3	6
III	8	9	M











$$\Rightarrow K = ? ; L = ? ; M = ?$$

Yukarıdaki tabloda K, L ve M kaçtır?

In the table above, what are the value of K, L and M, respectively ?

- A) 5 ; 4 ; 10
B) 5 ; 4 ; 9
C) 6 ; 4 ; 9
D) 6 ; 4 ; 10
E) 6 ; 5 ; 10







61.

			
	K		
			
			L

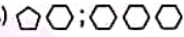
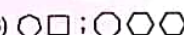
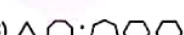
$$\Rightarrow K ; L = ?$$

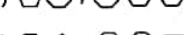
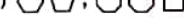
Yukarıdaki tabloda K ve L nedir?

In the table above, what are the value of K and L, respectively ?

- A)  ; 
B)  ; 
C)  ; 
D)  ; 
E)  ; 

62.

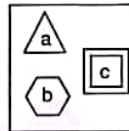
I.  $\rightarrow [(a-3) + (b-6) + (c-4-4)] - 4$

II.  $\rightarrow [(9-4) + (8-3-3) + (7-6)] - 5$

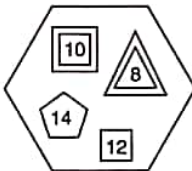
III.  $\rightarrow ?$

I. ve II. satırlarda belirlenen ilişkiye göre, III. satırı aşağıdaki sayılardan hangisi tamamlar?

Which of the number completes row III in accordance with the relation given in rows I and II?

- A) 11 B) 12 C) 13 D) 14 E) 15

YÖS

4

63, 64 ve 65. soruları aşağıdaki şekle göre cevaplayınız.
Answer questions 63, 64 and 65 in accordance with the figure given below.

Her soru birbirinden bağımsız olarak cevaplanacaktır.
Each question is to be answered independently.

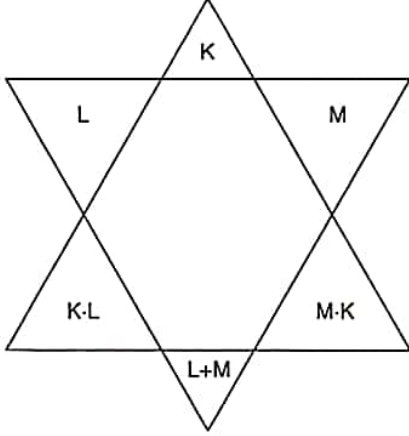

Yukarıdaki şekil K, L ve M harfleriyle gösterilen üç pozitif tamsayıyı içeren bazı işlemlere göre düzenlenmiştir. Harflerin gösterdiği sayılar her soruda farklı olabilir, fakat bunlarla yapılacak işlemler her soruda aynıdır.

The figure above has been organized according to various operations using three positive integers represented by the letters K, L and M. The integers represented by the letters may change from question to question, but the operations to be done remain the same.

63.

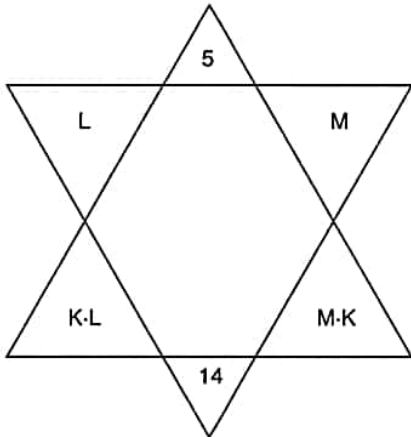

$$\Rightarrow L \cdot K + K \cdot M = ?$$

- A) 75 B) 70 C) 64 D) 48 E) 26

64.

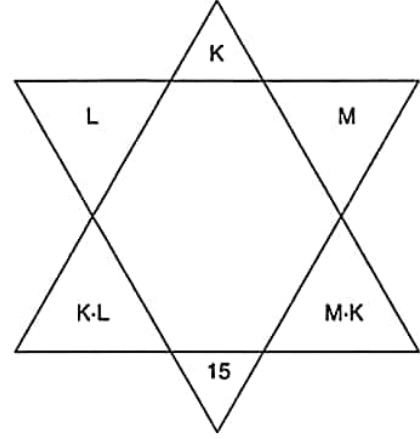

$$\Rightarrow \max(L \cdot M) = ?$$

- A) 16 B) 26 C) 36 D) 46 E) 56

65.

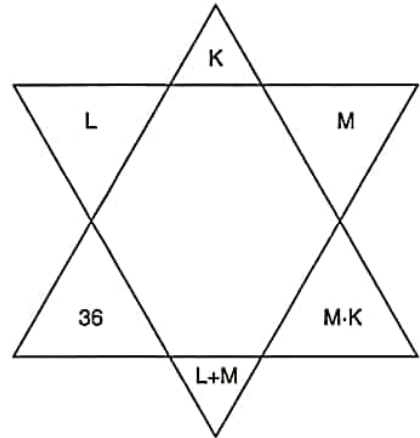

$$\Rightarrow \max(K + L) = ?$$

- A) 12 B) 24 C) 30 D) 36 E) 37

K U A R K Y A Y I N L A R I

K U A R K P U B L I C A T I O N S

YÖS

4

66.

4	6	8	9
3	6	9	9
2	4	6	?
4	8	12	3

Yukarıdaki tablodaki soru işaretinin yerine, aşağıdaki sayılardan hangisi gelmelidir?

Which of the following numbers does the question mark stand for in the table above?

- A) 10 B) 12 C) 15 D) 17 E) 18

68.

x	a	b	c
a		c	
b			108
c	54		

$$\Rightarrow c = ?$$

Yukarıdaki çarpma tablosunda a, b ve c harfleri pozitif birer tam sayının yerine kullanılmıştır. Buna göre, c kaçtır?

In the multiplication table above, the letters a, b and c each stand for a positive integer. Accordingly, what is the value of c?

- A) 18 B) 20 C) 22 D) 24 E) 26

67.

+	a	b	c
a			
b			d
c			

x	a	b	c
a		600	
b			1200
c	800		

$$\Rightarrow d = ?$$

Yukarıdaki toplama ve çarpma tablolarında a, b, c ve d harfleri pozitif birer tam sayının yerine kullanılmıştır. Buna göre, d kaçtır?

In the summation and multiplication tables above, the letters a, b, c and d each stands for a positive integer. Accordingly, what is the value of d?

- A) 70 B) 80 C) 90 D) 100 E) 110

69.

+	a	b	c
a			3b+12
b	c+4		
c		2a+7	

$$\Rightarrow a + b = ?$$

Yukarıdaki toplama tablosunda a, b ve c harfleri pozitif birer tam sayının yerine kullanılmıştır. Buna göre, a + b kaçtır?

In the summation table above, the letters a, b and c each stands for a positive integer. Accordingly, what is the value of a + b?

- A) 47 B) 46 C) 45 D) 44 E) 43

K U A R K Y A Y I N L A R I

K U A R K P U B L I C A T I O N S

70, 71, 72 ve 73. sorularda I. gruptaki her bir harf, rakam veya şekil, II. gruptaki farklı birer harf, rakam veya şekil ile gösterilmiştir. Buna göre, soru işaretleriyle belirtilen harfleri, rakamları veya şekilleri bulunuz. In questions 70, 71, 72 and 73 each letter, numeral or figure in group I stand for a different letter, numeral or figure in group II. Accordingly, find the letters, numerals or figures which the questions mark stands for.

70.

I.	II.
A T E Ş	} 7 1 6 1
Ş A T O	
Ş A K A	
C A K A	
T A K A	

⇒ TAKA = ?

- A) 7161 B) 4161 C) 4125
D) 1234 E) 2161

71.

I.	II.
E B E	} 7 5 7
K A S	
S E L	
A B A	
B A L	

⇒ KAS = ?

- A) 757 B) 942 C) 679 D) 454 E) 572

72.

I.	II.
K O N S E R	} 7 9 2 1 3 6
K A N E P E	
S E R P İ L	
K A N S E R	
P A R L A K	

⇒ KANSER = ?

- A) 792136 B) 792343 C) 136408
D) 752136 E) 496897

K U A R K Y A Y I N L A R I

K U A R K P U B L I C A T I O N S

73.

I.	II.
M U M	} * ▲ *
Z A M	
A Z A	
M A T	
T A T	

⇒ TAT = ?

- A) * ▲ * B) ▲ ■ ▲ C) ☆ ▲ *
D) ☆ ● ☆ E) ■ ▲ ☆

YÖS

4

74, 75 ve 76. sorulardaki verilen işlemlerde her harf sıfırdan ve birbirinden farklı birer rakamı göstermektedir. Buna göre, soru işareti ile belirtilen harf ya da işlemin değerini bulunuz.

In the operations which are given in questions 74, 75 and 76 each letter stands for a different numeral and different from zero. Accordingly, find the value of the letter or operation indicated by the questions mark.

$$74. \begin{array}{r} 3KL \\ + M82 \\ \hline L97 \end{array} \Rightarrow KLM = ?$$

- A) 154 B) 152 C) 251 D) 591 E) 915

$$75. \begin{array}{r} KKLL \\ LLMM \\ \hline L37K \end{array} \Rightarrow M = ?$$

- A) 1 B) 2 C) 6 D) 7 E) 8

$$76. \begin{array}{r} KLL \\ - LLK \\ \hline MN2 \end{array} \Rightarrow M = ?$$

- A) 4 B) 5 C) 6 D) 7 E) 8

K
U
A
R
K
Y
A
Y
I
N
L
A
R
IK
U
A
R
K
P
U
B
L
I
C
A
T
I
O
N
S

$$77. \text{ I. } x \Delta y = \begin{cases} 2x+y & , x+y < 10 \\ \left(\frac{y-x}{2}\right)^2 & , x+y > 10 \end{cases}$$

$$\text{ II. } (7 \Delta 2) \Delta 28 = ?$$

Yukarıdaki birinci eşitlikte Δ işaretinin görevi verilmiştir. Buna göre, ikinci eşitlikteki soru işaretinin yerine aşağıdaki sayılardan hangisi gelmelidir?

In the first equation above, the function of Δ is given Accordingly, which of the following numbers does the question mark stand for in the second equation?

- A) 9 B) 16 C) 25 D) 36 E) 49

78. I. $a \square b = \frac{a-b}{2}$

II. $a \blacktriangledown b = a^b - 1$

III. $(3 \blacktriangledown 4) \square (7 \square 3) = ?$

Yukarıdaki eşitliklerde \square ve \blacktriangledown işaretlerinin görevleri verilmiştir. Buna göre, üçüncü eşitlikteki soru işaretinin yerine aşağıdaki sayılardan hangisi gelmelidir?

In the equations above, the functions of \square and \blacktriangledown are given. Accordingly, which of the following numbers does the question mark stand for in the third equation?

- A) 36 B) 37 C) 38 D) 39 E) 40

79. I. $x \blacksquare y = 2x \circ y$

II. $x \circ y = 2y \blacktriangledown x$

III. $x \blacktriangledown y = x + y$

IV. $(4 \blacksquare 3) \circ (5 \blacksquare 2) = ?$

Yukarıdaki eşitliklerde \blacksquare , \circ ve \blacktriangledown işaretlerinin görevleri verilmiştir. Buna göre, dördüncü eşitlikteki soru işaretinin yerine aşağıdaki sayılardan hangisi gelmelidir?

In the equations above, the functions of \blacksquare , \circ and \blacktriangledown are given. Accordingly, which of the following numbers does the question mark stand for in the fourth equation?

- A) 42 B) 40 C) 38 D) 36 E) 34

80. I. $4 \square 2 = 60$

II. $3 \square 4 = 11$

III. $5 \square 7 = 76$

IV. $6 \square 9 = ?$

Yukarıdaki eşitliklerde \square işaretinin görevi verilmiştir. Buna göre, dördüncü eşitlikteki soru işaretinin yerine aşağıdaki sayılardan hangisi gelmelidir?

In the equations above, the function of \square is given. Accordingly, which of the following numbers does the question mark stand for in the fourth equation?

- A) 133 B) 134 C) 135 D) 136 E) 137

K
U
A
R
K
Y
A
Y
I
N
L
A
R
IK
U
A
R
K
P
U
B
L
I
C
A
T
I
O
N
S

1, 2, 3 ve 4. sorularda I. gruptaki her bir harf, rakam veya şekil, II. gruptaki farklı birer harf, rakam veya şekil ile gösterilmiştir. Buna göre, soru işaretiyle belirtilen harfleri, rakamları veya şekilleri bulunuz.

In questions 1, 2, 3 and 4 each letter, numeral or figure in group I stand for a different letter, numeral or figure in group II. Accordingly, find the letters, numerals or figures which the questions mark stands for.

1.

I.	II.
T A M	1 3 4
T A K	1 3 5
T A L	1 3 2
M A T	2 3 6
M A Ş	2 3 1

⇒ MAŞ = ?

- A) 132 B) 134 C) 135 D) 231 E) 236

2.

I.	II.
C F U B	V L Z R
U F N B	K R V R
N F U B	V L M R
C B N B	M L V R
N F T B	K L M R

⇒ FBUN = ?

- A) LVZR B) VLRM C) RMKL
D) RKVL E) LRMV

3.

I.	II.
T O R U N	8 6 4 7 2
B E T O N	8 7 2 3 9
H E R O N	4 7 1 3 2
B O N U S	4 7 9 3 2
T O S U N	5 6 1 7 2

⇒ TEBOR = ?

- A) 48137 B) 49327 C) 46871
D) 68715 E) 64937

4.

4	2	3	8	7	4
9	5	7	3	1	5
5	2	1	4	9	7
8	6	0	7	9	6

⇒

?

- A)

8	2	7	3	0	8
1	6	0	7	5	4
6	2	5	8	1	0
3	4	9	0	1	4
- B)

8	2	7	3	0	8
1	6	0	7	5	6
6	2	5	8	1	0
3	4	9	0	1	4
- C)

8	2	7	3	0	8
1	6	0	7	5	6
6	2	5	8	1	0
3	3	9	0	1	4
- D)

8	2	7	3	0	8
1	6	0	7	5	6
6	2	5	8	1	0
3	5	9	0	1	4
- E)

6	2	7	3	0	8
1	6	0	7	5	6
6	2	5	8	1	0
3	4	9	0	1	4

5 ve 6. sorulardaki verilen işlemlerde her harf sıfırdan ve birbirinden farklı birer rakamı göstermektedir. Buna göre, soru işareti ile belirtilen harf ya da işlemin değerini bulunuz.

In the operations which are given in questions 5 and 6 each letter stands for a different numeral and different from zero. Accordingly, find the value of the letter or operation indicated by the questions mark.

5.
$$\begin{array}{r} KLM \\ + TN \\ \hline 6LK \end{array} \Rightarrow M + N + T = ?$$

- A) 20 B) 22 C) 24 D) 26 E) 28

6.
$$\begin{array}{r} KLM \\ - MLK \\ \hline PT3 \end{array} \Rightarrow T - P = ?$$

- A) 1 B) 2 C) 3 D) 4 E) 5

7. I. $24 * 36 = 144$
II. $18 * 43 = 96$
III. $32 * 45 = 120$
IV. $71 * 23 = ?$

Yukarıdaki eşitliklerde * işaretinin görevi verilmiştir. Buna göre, dördüncü eşitlikteki soru işaretinin yerine aşağıdaki sayılardan hangisi gelmelidir?

In the equations above, the function of * is given. Accordingly which of the following numbers does the question mark stand for in the fourth equation?

- A) 13 B) 28 C) 40 D) 42 E) 48

8. I. $(8 \square 2) * 6 = 10$
II. $(12 * 4) \square 2 = 8$
III. $(16 \square 4) * (24 \square 8) = 7$
IV. $(12 * 8) \square (2 * 3) = ?$

Yukarıdaki eşitliklerde * ve \square işaretlerinin görevleri verilmiştir. Buna göre, dördüncü eşitlikteki soru işaretinin yerine aşağıdaki sayılardan hangisi gelmelidir?

In the equations above, the functions of * and \square are given. Accordingly, which of the following numbers does the question mark stand for in the fourth equation?

- A) 2 B) 3 C) 4 D) 5 E) 6

YÖS

5

9. I. $a^{-3} \Delta b^{-2} = a \cdot b$
 II. $a^b \square b^a = a + b$
 III. $\left(\frac{1}{27} \Delta \frac{1}{16}\right) - (64 \square 81) = ?$

Yukarıdaki eşitliklerde Δ ve \square işaretlerinin görevleri verilmiştir. Buna göre, üçüncü eşitlikteki soru işaretinin yerine aşağıdaki sayılardan hangisi gelmelidir?

In the equations above, the functions of Δ and \square are given. Accordingly, which of the following numbers does the question mark stand for in the third equation?

- A) 5 B) 4 C) 3 D) 2 E) 1

10. I. $a \blacktriangle b = a^b - (a \blacktriangle b) + 2$
 II. $a \blacksquare b = 2 \cdot (a \blacksquare b) - (a \cdot b)$
 III. $(4 \blacksquare 5) + (2 \blacktriangle 3) = ?$

Yukarıdaki eşitliklerde \blacktriangle ve \blacksquare işaretlerinin görevleri verilmiştir. Buna göre, üçüncü eşitlikteki soru işaretinin yerine aşağıdaki sayılardan hangisi gelmelidir?

In the equations above, the functions of \blacktriangle and \blacksquare are given. Accordingly, which of the following numbers does the question mark stand for in the third equation?

- A) 24 B) 25 C) 26 D) 27 E) 28

11.

+	a	b	c
a			
b	5-c		
c		2-a	b-1

$$\Rightarrow a + b + c = ?$$

Yukarıdaki toplama tablosunda a, b ve c harfleri pozitif birer tam sayının yerine kullanılmıştır. Buna göre, $a + b + c$ kaçtır?

In the summation table above, the letters a, b and c each stands for a positive integer. Accordingly, what is the value of $a + b + c$?

- A) 6 B) 7 C) 8 D) 9 E) 10

12.

x	a	b	c
a		50	
b			a
c	4-b		

$$\Rightarrow a + c = ?$$

Yukarıdaki çarpma tablosunda a, b ve c harfleri pozitif birer tam sayının yerine kullanılmıştır. Buna göre, $a + c$ kaçtır?

In the multiplication table above, the letters a, b and c each stands for a positive integer. Accordingly, what is the value of $a + c$?

- A) 5 B) 7 C) 10 D) 12 E) 15

YÖS

5

13.

+	a	b	c
a	c		
b			

x	a	b	c
a		2·c	
b			

$$\Rightarrow b = ?$$

Yukarıdaki toplama ve çarpma tablolarında a, b ve c harfleri pozitif birer tamsayının yerine kullanılmıştır. Buna göre, b kaçtır?

In the summation and multiplication tables above, the letters a, b and c each stands for a positive integer.

Accordingly, what is the value of b?

- A) 2 B) 4 C) 6 D) 8 E) 12

15.

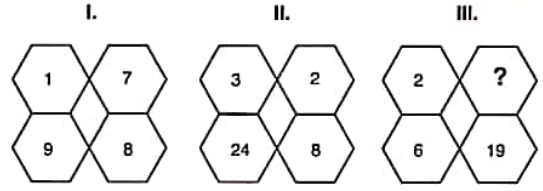

I. ve II. şekillerde verilen kurala göre, III. şekildeki soru işaretinin yerine aşağıdaki sayılardan hangisi gelmelidir?

Which of the following numbers does the question mark stand for in figure III, in accordance with the rule established in figure I and II?

- A) 5 B) 6 C) 7 D) 8 E) 9

14.

I. II. III.

4		3		1
	2		6	
8		5		7
	9		3	
4		K		8

	8		5	
		9		
	14		13	
		13		
	11		15	

			14	
			9	
			28	
			13	
		L		

$$\Rightarrow K + L = ?$$

Yukarıdaki sayı-şekil dizisine göre K + L kaçtır?

What is the value of K + L, according to the number-figure sequence above?

- A) 29 B) 30 C) 31 D) 32 E) 33

16.

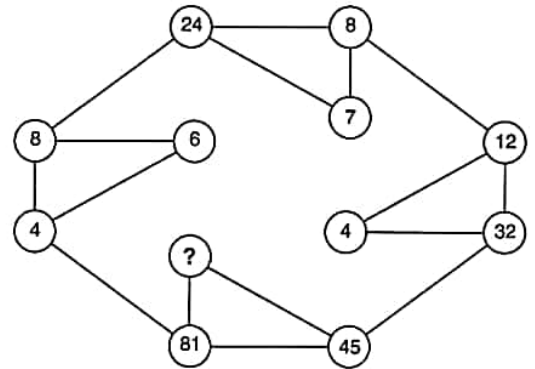

Yukarıdaki sayı-şekil ilişkisine göre soru işaretinin yerine aşağıdaki sayılardan hangisi gelmelidir?

Which of the following numbers does the question mark stand for, according to the number-figure relation above?

- A) 5 B) 6 C) 7 D) 8 E) 9

YÖS

5

17.

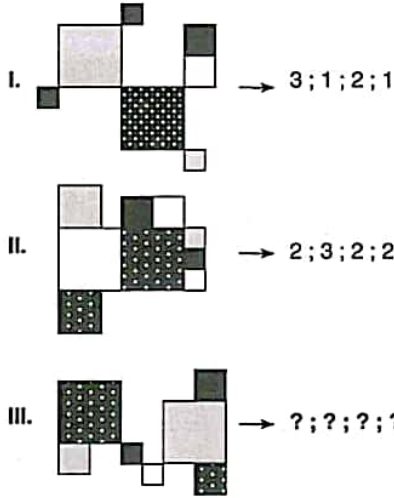

I. ve II. satırlarda belirlenen ilişkiye göre, III. satırı aşağıdaki sayılardan hangisi tamamlar?

Which of the following numbers completes III. in accordance with the relation established in I and II?

- A) 2; 1; 2; 2 B) 2; 2; 1; 2
C) 1; 2; 2; 2 D) 2; 2; 2; 1
E) 2; 1; 2; 1

18.

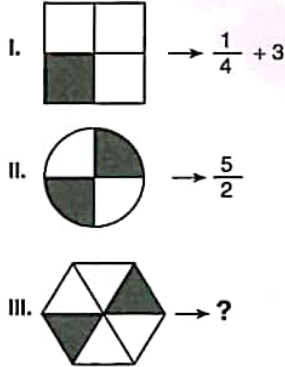

I. ve II. satırlarda belirlenen ilişkiye göre, III. satırı aşağıdaki sayılardan hangisi tamamlar?

Which of the following numbers completes III. in accordance with the relation established in I and II?

- A) 2 B) $\frac{10}{3}$ C) 4 D) $\frac{13}{3}$ E) 5

19.

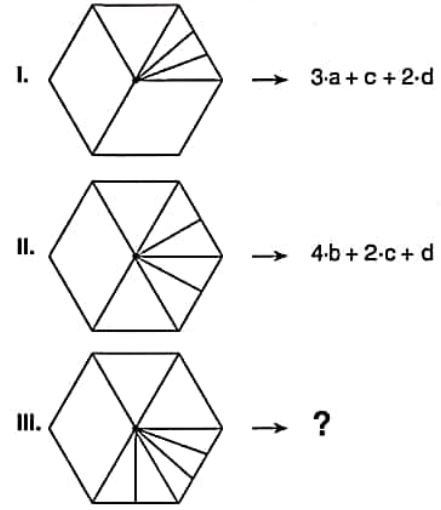

I. ve II. satırlarda belirlenen ilişkiye göre, III. satırı aşağıdaki sayılardan hangisi tamamlar?

Which of the following numbers completes III. in accordance with the relation established in I and II?

- A) $2-b+d+3-a+2-c$
B) $3-a+b+2-c+d$
C) $c+2-d+3-b+a$
D) $2-c+3-b+d+2-a$
E) $a+2-b+3-c+4-d$

20.

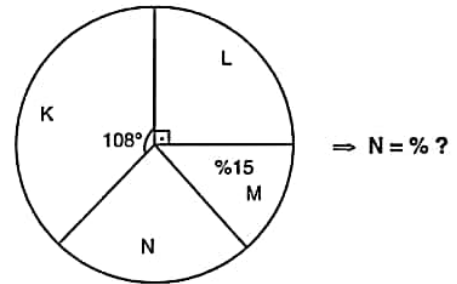

Yukarıdaki dairesel grafikte verilen bilgilere göre, N yüzde kaçtır?

According to the information in the circular chart above, what is the percentage of N?

- A) 20 B) 25 C) 30 D) 35 E) 40

K U A R K Y A Y I N L A R I

K U A R K P U B L I C A T I O N S

YÖS

5

21.

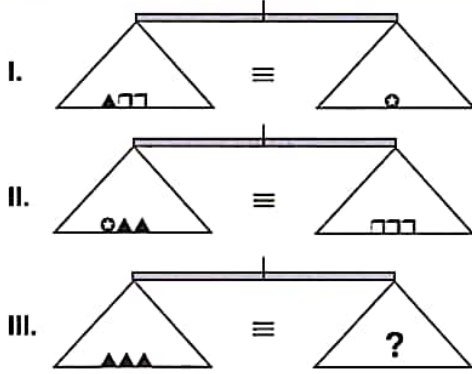

Yukarıdaki terazilerin üçü de dengededir. Buna göre, III. terazideki soru işaretini aşağıdakilerden hangisi göstermektedir?

All three scales above are in balance. Accordingly, which of the following does the question mark stand for in the third scale?

- A) ○ B) ○○ C) ○□ D) □□ E) □

22.

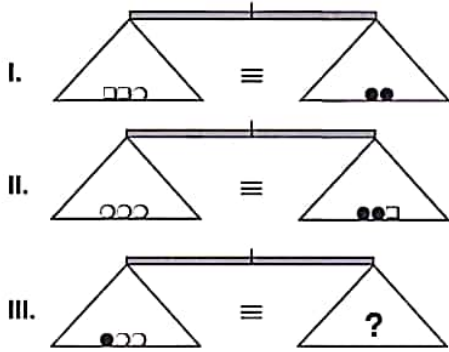

Yukarıdaki terazilerin üçü de dengededir. Buna göre, III. terazideki soru işaretini aşağıdakilerden hangisi göstermektedir?

All three scales above are in balance. Accordingly, which of the following does the question mark stand for in the third scale?

- A) ●●□□ B) ●□□ C) ●●□
D) □□□● E) ●●●□□

23.

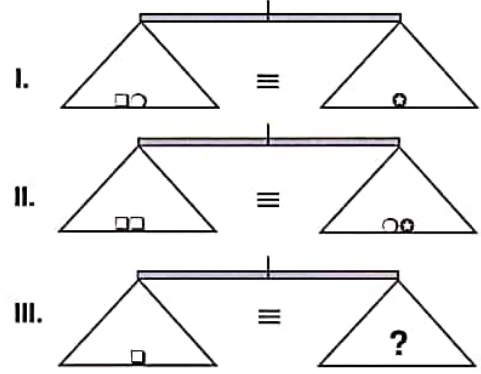

Yukarıdaki terazilerin üçü de dengededir. Buna göre, III. terazideki soru işaretini aşağıdakilerden hangisi göstermektedir?

All three scales above are in balance. Accordingly, which of the following does the question mark stand for in the third scale?

- A) ○ B) ⊛ C) ○○ D) ⊛○ E) ○⊛⊛

24.

				Sonuç (Result)
◆□	⊛○	●■	▲⊛	□⊛○
⊛○	□●	○▲	◆■	○■●
□⊛	◆■	□●	○□	???
●■	○⊛	◆○	⊛●	■●⊛

Yukarıdaki tabloya göre soru işaretlerinin yerine hangi şekiller gelmelidir?

According to the table above, which of the figures do the question marks stand for?

- A) ⊛■□ B) □○◆ C) ⊛□■
D) ◆□⊛ E) □●○

K U A R K Y A Y I N L A R I

K U A R K P U B L I C A T I O N S

YÖS

5

25.

⊛	K	L	M	N	R
K	R	N	K	M	L
L	N	M	K	R	M
M	K	K	K	N	L
N	M	R	N	L	K
R	L	M	L	K	N

$$((K \otimes x) \otimes (M \otimes L)) \otimes R = N \Rightarrow x = ?$$

Yukarıdaki tablo \otimes işlemine göre düzenlenmiştir. Buna göre, x nedir?

The table above is organized according to the \otimes operation. Accordingly, what is the value of x?

- A) K B) L C) M D) N E) R

27, 28 ve 29. sorularda, verilen her bir şekil matrisindeki soru işaretinin yerine hangi şeklin getirilmesi gerektiğini bulunuz.

In questions 27, 28 and 29, find the figure which should replace the question mark in each given figure matrix.

27.

		?

- A)
- B)
- C)
- D)
- E)

26. Aşağıdaki şekillerden hangisi bir özelliğine göre diğerlerinden farklıdır?

Which of the following figure is different than the others according to a certain property?

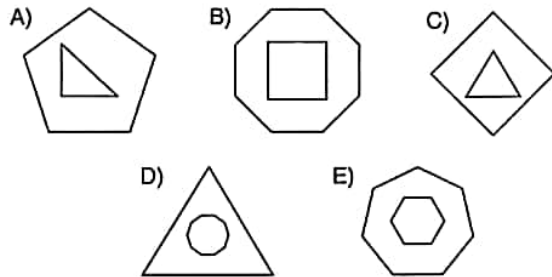

K U A R K Y A Y I N L A R I

K U A R K P U B L I C A T I O N S

YÖS

5

28.

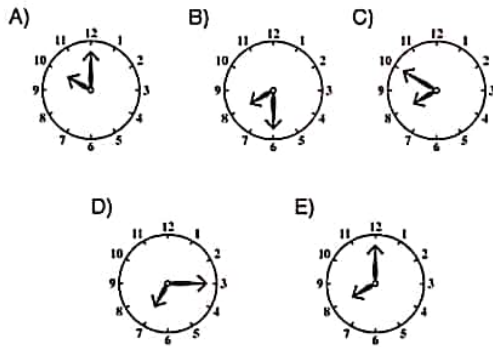
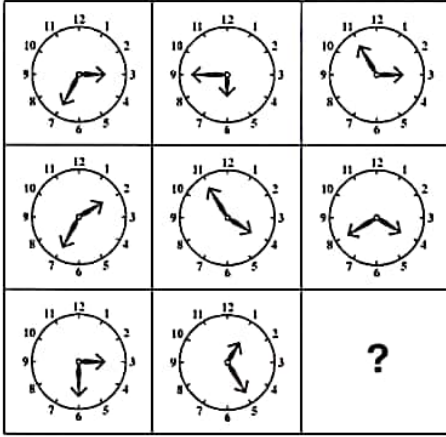

29.

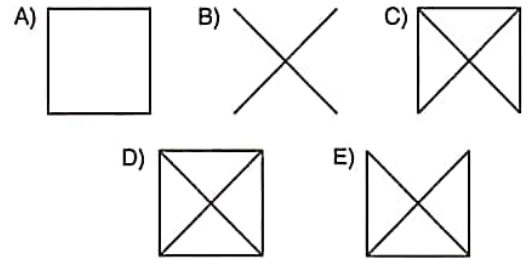
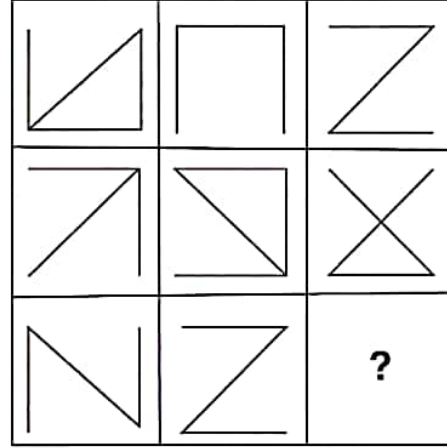

30, 31 ve 32. sorularda, I. satırda belirlenen ilişkiye göre II. satırı hangi şeklin tamamladığını bulunuz.

In questions 30, 31 and 32, find the figure which completes row II, in accordance with the relation in row I.

30.

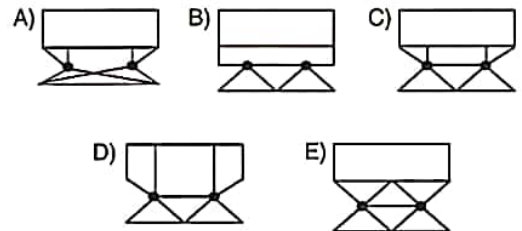
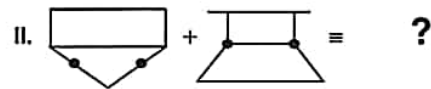
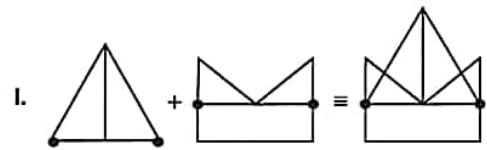

YÖS

5

31.

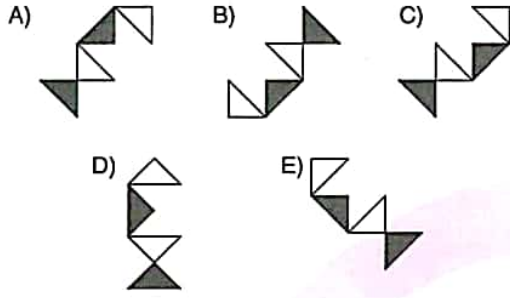
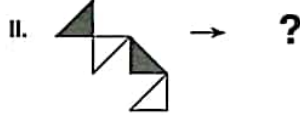
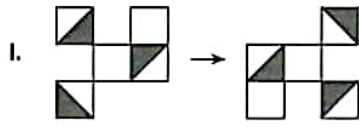

32.

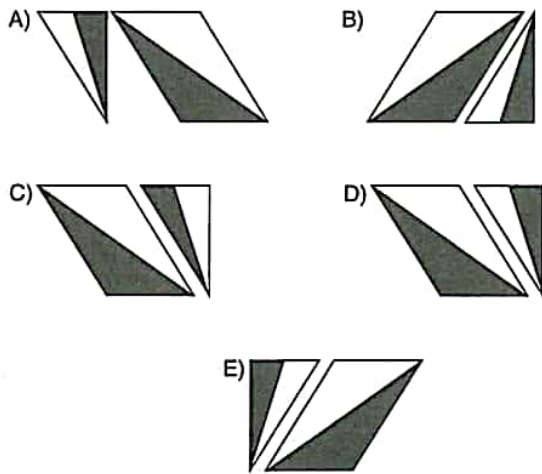
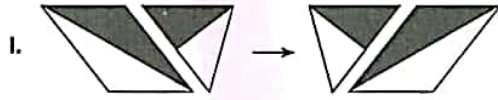

33.

I	3	2	1
II	1	2	3
III	4	3	3
IV	1	2	2

$$\Rightarrow I = ? ; II = ? ; III = ? ; IV = \oplus$$

Yukarıdaki tabloya göre I, II ve III aşağıdakilerden hangisidir?

According to the table above, which of the following stands for I, II and III?

	I	II	III
A)			
B)			
C)			
D)			
E)			

K U A R K Y A Y I N L A R I

K U A R K P U B L I C A T I O N S

YÖS

5

34.

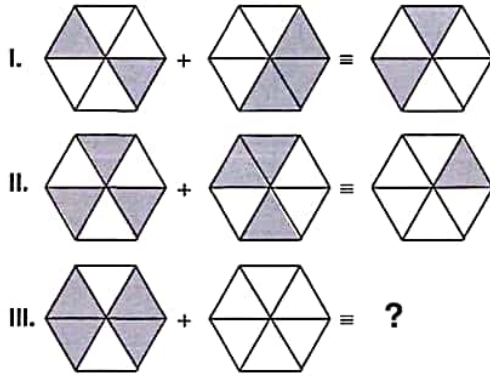

I. ve II. satırda belirlenen ilişkiye göre III. satırı hangi şeklin tamamladığını bulunuz.

Find the figure which completes row III, in accordance with the relation established in rows I and II.

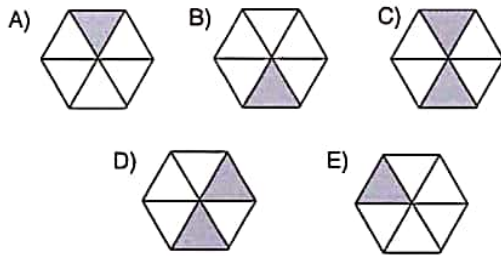

35, 36, 37 ve 38. sorularda, verilen her şekil dizisindeki soru işaretinin yerine hangi şeklin getirilmesi gerektiğini bulunuz.

In questions 34, 35, 36 and 37. find the figure which should replace the question mark in each given figure sequence.

K U A R K Y A Y I N L A R I

35.

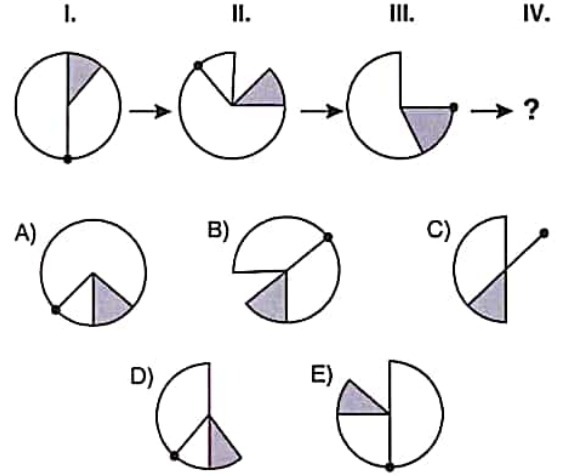

K U A R K P U B L I C A T I O N S

36.

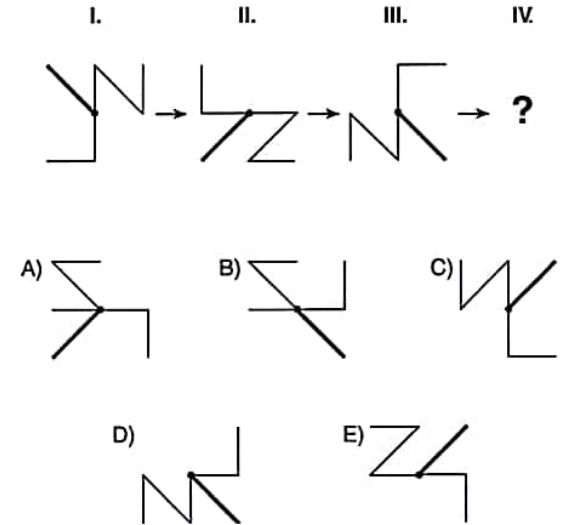

YÖS

5

37. I. II. III. IV.

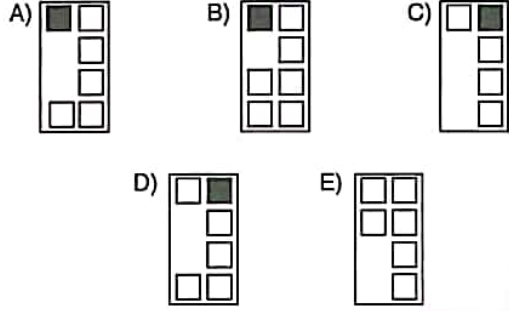
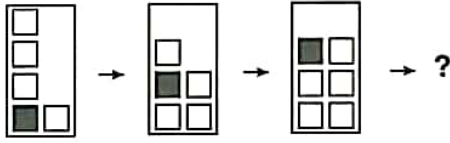

39 ve 40. sorularda, soru işaretinin yerine getirilmesi gereken şekli bulunuz.

In question 39 and 40, find the figure to replace the question mark.

39. I. II. III. IV.

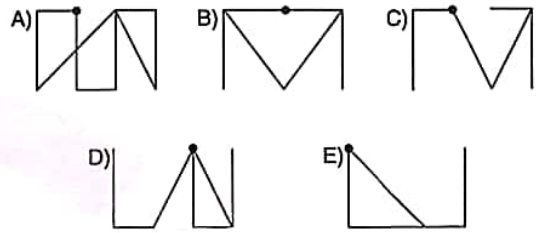

38. I. II. III. IV.

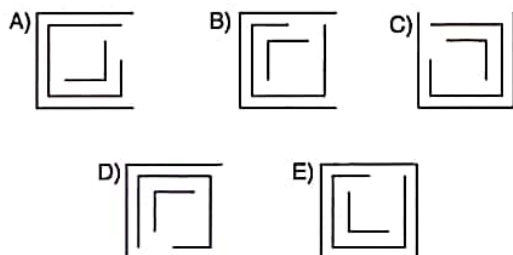
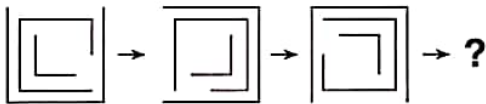

40. I. II. III. IV.

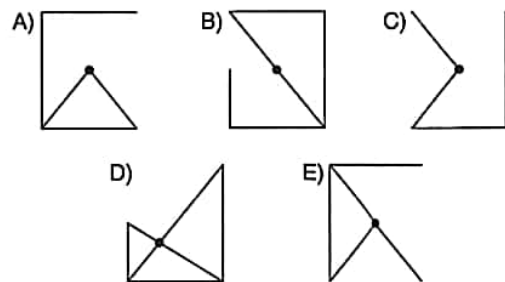
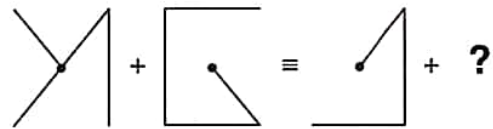

K U A R K Y A Y I N L A R I

K U A R K P U B L I C A T I O N S

YÖS

5

41. soruyu aşağıdaki örnekte verilen ilişkiye göre cevaplayınız.

Answer question 41, in accordance with the relation established in the example below.

ÖRNEK / EXAMPLE:

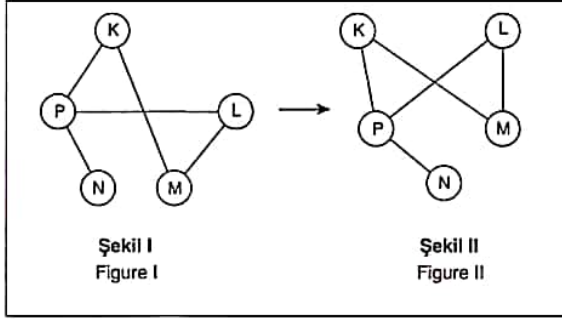

K, L, M, N ve P harfleri I. şekildeki gibi birbirine bağlanmıştır. I. şekildeki bağlantı sayıları ve birbirine bağlanan harfler

değişmemek koşuluyla II. şekil elde edilmiştir.

The letters K, L, M, N and P are linked as in figure I. figure II. has been constructed so as not to change the number of links and the letters that are linked to each other in figure I.

42. soruyu aşağıdaki örnekte verilen ilişkiye göre cevaplayınız.

Answer question 42, in accordance with the relation established in the example below.

ÖRNEK / EXAMPLE:

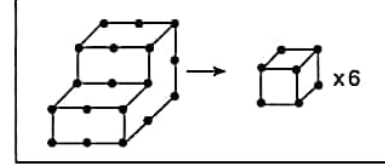

42.

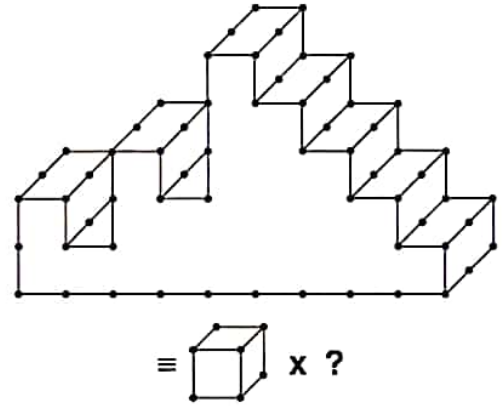

- A) 40 B) 42 C) 44 D) 46 E) 48

41.

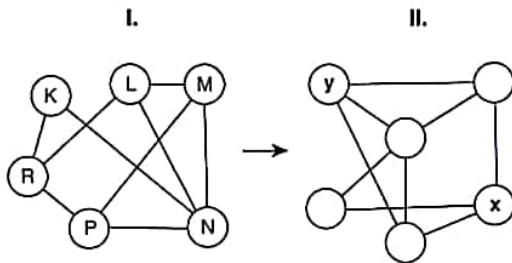

$\Rightarrow x = ? ; y = ?$

- A) R; M B) M; P C) L; M D) R; K E) M; R

K
U
A
R
K
Y
A
Y
I
N
L
A
R
I

K
U
A
R
K
P
U
B
L
I
C
A
T
I
O
N
S

YÖS

5

43. soruyu aşağıdaki örnekte verilen ilişkiye göre cevaplayınız.

Answer question 43, in accordance with the relation established in the example below.

ÖRNEK / EXAMPLE:

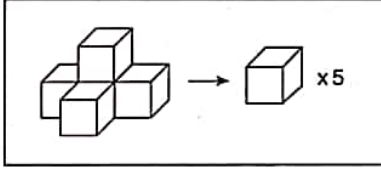

43.

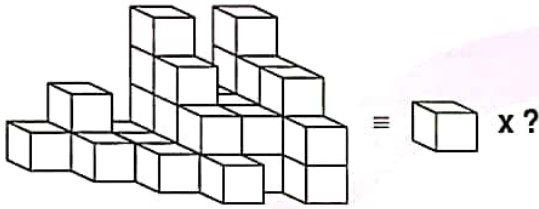

- A) 33 B) 34 C) 35 D) 36 E) 37

44.

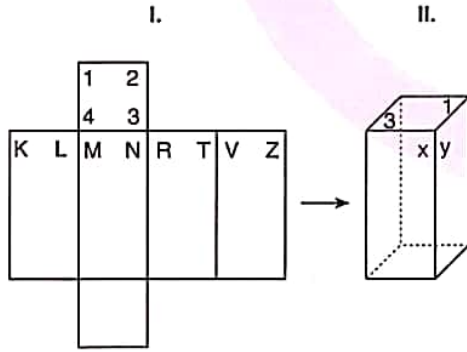

$$\Rightarrow x = ? ; y = ?$$

II. şekildeki cisim, I. şeklin kapalı halidir. Buna göre, II. şekildeki x ve y aşağıdakilerden hangisidir?

The object in figure II is the closed form of figure I. Accordingly, which of the following stands for x and y in figure II?

- A) L ; M B) N ; R C) Z ; K D) T ; V E) V ; K

45.

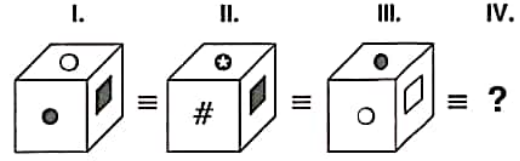

Yukarıdaki şekillerin tümü aynı nesneyi göstermektedir. Buna göre, aşağıdakilerden hangisi bu nesnenin başka bir görünümüdür?

The figures above all represent the same object.

Accordingly, which of the following is another view of the object?

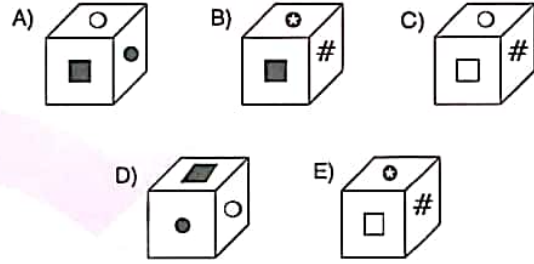

K U A R K Y A Y I N L A R I

K U A R K P U B L I C A T I O N S

YÖS

5

50.

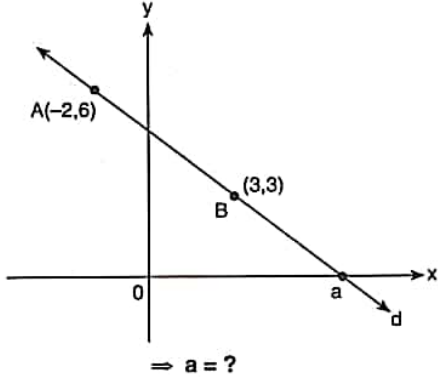

- A) 4 B) 5 C) 6 D) 7 E) 8

52.

$$x, y \in \mathbb{N}^+,$$

$$45! = x \cdot 64^y,$$

$$\min(x) \text{ için/for } \Rightarrow y = ?$$

- A) 3 B) 5 C) 6 D) 9 E) 12

K
U
A
R
K
Y
A
Y
I
N
L
A
R
I

$$53. \quad 0,\overline{3} + \frac{1}{0,4 + \frac{1}{0,5}} = ?$$

- A) $\frac{1}{2}$ B) $\frac{2}{3}$ C) $\frac{3}{4}$ D) $\frac{4}{5}$ E) $\frac{5}{6}$

K
U
A
R
K
P
U
B
L
I
C
A
T
I
O
N
S

51.

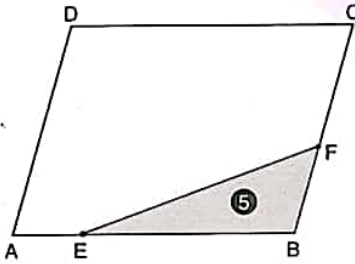

ABCD bir paralelkenar / ABCD is a parallelogram

$$|AB| = 6 \cdot |AE|$$

$$|BC| = 4 \cdot |BF|$$

$$A(\triangle EBF) = 5 \text{ cm}^2 \Rightarrow A(ABCD) = ? \text{ cm}^2$$

- A) 36 B) 40 C) 44 D) 48 E) 54

$$54. \quad \frac{\frac{y}{x} - \frac{x}{y}}{x - \frac{x^2}{y}} : \left(2y + \frac{x^2 + y^2}{x}\right) = ?$$

- A) $\frac{1}{x}$ B) $\frac{1}{y}$ C) $\frac{1}{x+y}$
D) $\frac{1}{y(x+y)}$ E) $\frac{1}{x(x+y)}$

YÖS

5

55. $\int \frac{\ln x^4}{x} dx = ?$

- A) $4x^2 + C$ B) $4x + C$ C) $\ln^2 x + 4x + C$
 D) $2\ln^2 x + C$ E) $\frac{4}{x} \ln^3 x + C$

56. $2 \cdot 3^x - 3 \cdot 3^{x-1} + 4 \cdot 3^{x-2} = 39 \Rightarrow 2^{5-x} = ?$

- A) 1 B) 2 C) 3 D) 4 E) 8

57. $(xyz) \in \mathbb{N}, (yz) \in \mathbb{N}$
 $\Rightarrow \max(A) = ?$

- A) 10 B) 11 C) 89 D) 90 E) 91

$$\begin{array}{r|l} xyz & yz \\ \hline & A \end{array}$$

58. $\int_{\frac{\pi}{6}}^{\frac{\pi}{3}} \tan^2 x dx = ?$

- A) $\frac{4\sqrt{3}-\pi}{3}$ B) $\frac{2\sqrt{3}-3\pi}{6}$ C) $\frac{4\sqrt{3}-\pi}{6}$
 D) $\frac{4\sqrt{3}+2\pi}{3}$ E) $\frac{\sqrt{3}-\pi}{2}$

59. $x \neq 1, y \neq 1,$
 $x, y \in \mathbb{R}^+$

$x^y \cdot y^{y-2} = x^3$

$\frac{x}{y} = \frac{1}{y^3} \Rightarrow y = ?$

- A) 2 B) 3 C) 4 D) 5 E) 6

60. $x \cdot |x-1| - 4 \cdot |1-x| = x-4 \Rightarrow \text{ÇK(SS)} = ?$

- A) {0} B) {0,2} C) {4}
 D) {0,2,4} E) \emptyset

K U A R K Y A Y I N L A R I

K U A R K P U B L I C A T I O N S

YÖS

5

61. $(f \circ g)(x) = \frac{5x+3}{3}$,
 $g^{-1}(8) = 3 \Rightarrow f^{-1}(6) = ?$
 A) 3 B) 4 C) 6 D) 8 E) 10

62. $n(A \cap B) + 6 = n(A)$
 $\frac{n(A \cup B)}{6} = \frac{n(A \setminus B)}{3} = \frac{n(B \setminus A)}{2} \Rightarrow n(A \cup B) = ?$
 A) 6 B) 8 C) 10 D) 12 E) 15

63. $(1! + 2! + 3! + \dots + 30!)^{30} \equiv x \pmod{5}$
 $\Rightarrow x = ?$
 A) 0 B) 1 C) 2 D) 3 E) 4

64. $\frac{P(7-x)}{Q(x+1)} = 5x^2 - 3x + 1$

$$\frac{Q(x)}{3} \Big|_{x-4} \quad \frac{P(x)}{K(x)} \Big|_{x-4} \Rightarrow K(x) = ?$$

- A) 92 B) 98 C) 99 D) 107 E) 111

65. $2x^2 - 5x + 4 = 0$
 $\text{ÇK}(SS) = \{x_1, x_2\}$
 $\Rightarrow x_1 \cdot (3x_2 - 4) + x_2 \cdot (2x_1 - 4) = ?$
 A) -10 B) -5 C) 0 D) 5 E) 10

66. $x \in \mathbb{Z}$,
 $\frac{(x-1)^2 \cdot |x+2|}{(x-2)^2} \leq 0 \Rightarrow \sum x = ?$

- A) -2 B) -1 C) 0 D) 1 E) 2

K
U
A
R
K
Y
A
Y
I
N
L
A
R
IK
U
A
R
K
P
U
B
L
I
C
A
T
I
O
N
S

67. $(2x^2 - \frac{1}{2x})^6 = \dots + A \cdot x^6 + \dots \Rightarrow A = ?$

- A) -60 B) -40 C) 20 D) 40 E) 60

69. $\log_2 3 = x \Rightarrow \log_{27} 16 = ?$

- A) $\frac{4}{3x}$ B) $\frac{3}{4x}$ C) $\frac{3x}{4}$ D) $\frac{4x}{3}$ E) $4x$

K
U
A
R
K
Y
A
Y
I
N
L
A
R
I

70. $\sum_{k=4}^{48} \frac{1}{\sqrt{k+1} + \sqrt{k}} = ?$

- A) 4 B) 5 C) 6 D) 7 E) 8

K
U
A
R
K
P
U
B
L
I
C
A
T
I
O
N
S

68.

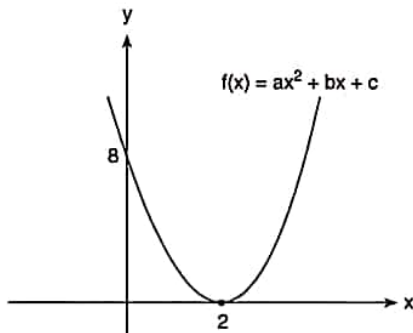

$\Rightarrow (f \circ f)(4) = ?$

- A) 18 B) 24 C) 36 D) 48 E) 72

71. $z_1 = 2 \cdot \left[\cos \frac{\pi}{6} + i \sin \frac{\pi}{6} \right]$

$z_2 = \sqrt{24} + i \Rightarrow |z_1^{-1} \cdot z_2| = ?$

- A) 3 B) $\frac{5}{2}$ C) 2 D) $\frac{3}{2}$ E) 1

YÖS

5

72.

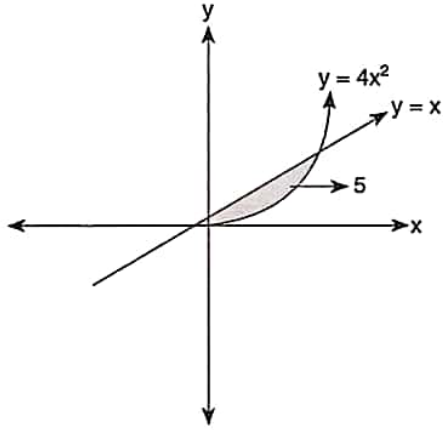

$$\Rightarrow S = ? \text{ br}^2 (u^2)$$

- A) $\frac{1}{48}$ B) $\frac{1}{64}$ C) $\frac{1}{72}$ D) $\frac{1}{80}$ E) $\frac{1}{96}$

73. $A = \begin{bmatrix} 12 & 7 \\ 5 & 3 \end{bmatrix} \Rightarrow |A^{100}| = ?$

- A) 1 B) 2 C) 2^{25} D) 2^{50} E) 2^{100}

74. $\lim_{x \rightarrow 2} \frac{\sin^2(x-2)}{(2x-4)^2} = ?$

- A) $\frac{1}{4}$ B) $\frac{1}{2}$ C) 0 D) 2 E) 4

75. $f(x) = mx^2 - 3x + 5$

$$\lim_{x \rightarrow 4} \frac{f(x) - f(4)}{x - 4} = 13 \Rightarrow m = ?$$

- A) 1 B) 2 C) 3 D) 4 E) 5

76. $f(x) = e^{x^2} \cdot \ln 3x \Rightarrow f'(1) = ?$

- A) $e \cdot \ln(3e)$ B) $e^2 \cdot \ln(3e)$ C) $e \cdot \ln(9e)$
D) $\ln(9e^2)$ E) $\ln(9e)^2$

K U A R K Y A Y I N L A R I

K U A R K P U B L I C A T I O N S

YÖS

5

$$77. \lim_{x \rightarrow -\infty} \frac{-4x+5+\sqrt{9x^2-7x+2}}{3x-4-\sqrt{16x^2+5x-1}} = ?$$

- A) -7 B) -1 C) $-\frac{1}{7}$ D) $\frac{1}{7}$ E) 7

$$79. f(x) = \log_{(\cos x)}(\sin x) \Rightarrow f\left(\frac{\pi}{4}\right) = ?$$

- A) $\frac{2}{\ln\left(\frac{\sqrt{2}}{2}\right)}$ B) $\frac{1}{\ln\left(\frac{\sqrt{2}}{2}\right)}$ C) 0
 D) $\ln\frac{\sqrt{2}}{2}$ E) $2 \cdot \ln\left(\frac{\sqrt{2}}{2}\right)$

K
U
A
R
K
Y
A
Y
I
N
L
A
R
IK
U
A
R
K
P
U
B
L
I
C
A
T
I
O
N
S

78.

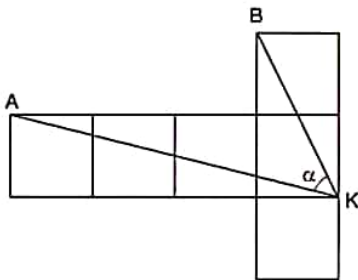

Şekil 6 eş karedir. / The figure contains 6 identical squares.

$$m(\widehat{AKB}) = \alpha \Rightarrow \tan \alpha = ?$$

- A) $\frac{5}{6}$ B) $\frac{6}{7}$ C) $\frac{7}{8}$ D) $\frac{7}{6}$ E) $\frac{6}{5}$

$$80. f(x) = \tan^3 2x \Rightarrow f\left(\frac{\pi}{8}\right) = ?$$

- A) 3 B) 4 C) 6 D) 12 E) 18

1. $[(2a - b - c) - (a - b)] - [(a + b - c) - (b - a)] = ?$
 A) $-2a - b$ B) $-a$ C) $a - 2b + c$
 D) $-2c + b$ E) $a - b + c$

4. $\sqrt[4]{3} = x \Rightarrow \frac{3^{\frac{1}{2}} - 3^{\frac{1}{4}}}{3^{\frac{1}{2}} - 1} = ?$
 A) $\frac{x}{x+1}$ B) $\frac{x}{x-1}$ C) $\frac{x+1}{x}$
 D) $\frac{x-1}{x}$ E) $x - 1$

K
U
A
R
K
Y
A
Y
I
N
L
A
R
I

2. $\left(\frac{1}{8} - \frac{1}{4}\right) - \left(\frac{1}{5} - \frac{1}{4}\right) + \left(\frac{1}{5} - \frac{1}{8}\right) = ?$
 A) $-\frac{1}{2}$ B) $-\frac{2}{5}$ C) 0 D) $\frac{1}{2}$ E) $\frac{2}{5}$

K
U
A
R
K
P
U
B
L
I
C
A
T
I
O
N
S

3. $\left[\frac{27^x - 8^x}{3^{2x} + 6^x + 4^x}\right] \cdot \frac{1}{9^x - 4^x} = ?$
 A) $3^x - 2^x$ B) $3^x + 2^x$ C) $\frac{1}{3^x - 2^x}$
 D) $\frac{1}{3^x + 2^x}$ E) $9^x - 2^x$

5. $\left[\frac{a}{a+b} - \frac{b}{a-b}\right] : \frac{1}{a^2 - b^2} + 2ab = ?$
 A) $a + b$ B) $a - b$ C) $a^2 - b^2$
 D) $2a - 2b$ E) $-ab$

YÖS

6

6. G bölgesindeki restoran şube sayıları
(Number of Restaurant Franchises in Region G)

Restoran (Restaurant)	Şube sayısı (Number of Franchises)
X	8
Y	20
Z	3
T	12

Yukarıdaki tablo G bölgesindeki restoran şube sayısını gösteriyor. G bölgesindeki Y restoranının şube sayısı ile Z restoranının şube sayısı arasındaki fark nedir?

The table above list the number of four restaurants franchises in Region G. What is the difference between the number of franchises of Restaurant Y and Restaurant Z?

- A) 8 B) 13 C) 15 D) 17 E) 19

8. $2x + 3y + 4z = 24$,
 $x + 2y + 3z = 16$
 $\Rightarrow x + y + z = ?$

- A) 4 B) 6 C) 8 D) 10 E) 12

K
U
A
R
K
Y
A
Y
I
N
L
A
R
IK
U
A
R
K
P
U
B
L
I
C
A
T
I
O
N
S

7. $A = \{1, 2, 3, 5, 6\}$,
 $B = \{1, 4, 5, 7\}$,
 $C = \{4, 5, 6, 8\} \Rightarrow (A \cap B) \setminus C = ?$

- A) {1} B) {1, 3} C) {1, 5}
D) {1, 4, 5} E) {4, 5}

9. $\frac{3a+2}{c} = \frac{2b-2a}{a} = \frac{c-b-2}{b} = k \Rightarrow k = ?$

- A) -2 B) -1 C) 0 D) 1 E) 2

YÖS

6

10. $3x = 4y = 5z,$

$$\frac{2}{x} + \frac{2}{y} + \frac{2}{z} = 48 \Rightarrow 2x = ?$$

- A)
- $\frac{1}{4}$
- B)
- $\frac{1}{3}$
- C)
- $\frac{1}{2}$
- D) 1 E) 2

11. $x, y \in \mathbb{Z},$

$$-10 < -x \leq 12,$$

$$-6 < y \leq -1$$

$$\Rightarrow \max(-x - y) = ?$$

- A) -15 B) -8 C) -3 D) 8 E) 17

12. $(5x) \in \mathbb{Z}, 2 \cdot 15x - 41 + 6 < 12 \Rightarrow \sum (5x) = ?$

- A) 12 B) 16 C) 18 D) 20 E) 25

13. $f(2x-1) = x+2 \Rightarrow f(x+1) = ?$

- A)
- $f(x)$
- B)
- $2 \cdot f(x) + 1$
- C)
- $\frac{2 \cdot f(x) + 1}{2}$

- D)
- $\frac{2 \cdot f(x) - 1}{3}$
- E)
- $\frac{3 \cdot f(x) - 1}{2}$

K
U
A
R
K
Y
A
Y
I
N
L
A
R
IK
U
A
R
K
P
U
B
L
I
C
A
T
I
O
N
S

14. 7 öğrenci 2 öğretmen arasından oluşturulacak ekiplerin kaç tanesinde öğretmen ve öğrenci sayıları eşittir?

How many teams that is formed from among 7 students and 2 teachers, contains equal number of students and teachers?

- A) 14 B) 18 C) 21 D) 28 E) 35

YÖS

6

15. $P(x-1) = x^2 + ax - 1,$

$$\frac{P(x)}{4} \Big|_{x-2} \Rightarrow a = ?$$

- A)
- $-\frac{4}{3}$
- B)
- -1
- C)
- 1
- D)
- $\frac{1}{3}$
- E)
- $\frac{2}{3}$

16. $x^2 - 3x - 5 = 0, \text{ÇK(SS)} = \{x_1, x_2\}$

$$\Rightarrow (x_1 - 2) \cdot (x_2 - 2) = ?$$

- A)
- -7
- B)
- -4
- C)
- -1
- D)
- 1
- E)
- 3

17. $\frac{(x^2+5) \cdot |x-1|}{x^3-1} \leq 0 \Rightarrow \text{ÇK(SS)} = ?$

- A)
- \emptyset
- B)
- $(-\infty, -1)$
- C)
- $(-\infty, 1)$
-
- D)
- $(-\infty, 0)$
- E)
- $(-\infty, -1]$

18.

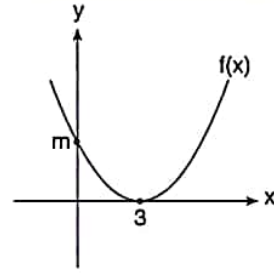

$$f(2) = \frac{1}{3} \Rightarrow m = ?$$

- A)
- 1
- B)
- 2
- C)
- 3
- D)
- 4
- E)
- 5

19. $\binom{6}{3} + P(3,1) + P(4,2) = ?$

- A)
- 20
- B)
- 25
- C)
- 30
- D)
- 35
- E)
- 40

20. $f(x) = \log_5 \left(\frac{12-3x}{x+1} \right) \Rightarrow \text{ÇK(SS)} = ?$

- A)
- $[0, \infty)$
- B)
- $(-1, 4)$
-
- C)
- $(-\infty, -1) \cup (4, \infty)$
- D)
- $[-4, 1]$
-
- E)
- $(0, 4)$

K
U
A
R
K
Y
A
Y
I
N
L
A
R
IK
U
A
R
K
P
U
B
L
I
C
A
T
I
O
N
S

YÖS

6

21. $\log_2 [1 + \log_3(x-4)] = 2 \Rightarrow x = ?$

- A) 27 B) 28 C) 29 D) 30 E) 31

22.

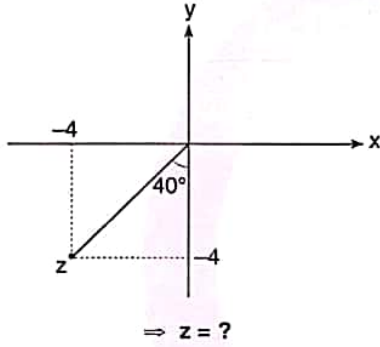

- A) $4 \cdot \text{cis}220^\circ$ B) $4 \cdot \text{cis}230^\circ$
 C) $4\sqrt{2} \cdot \text{cis}230^\circ$ D) $4\sqrt{2} \cdot \text{cis}30^\circ$
 E) $4 \cdot \text{cis}240^\circ$

23. $[AC] \perp [BC]$,
 $|BC| = 7 \text{ cm}$,
 $|AC| = 24 \text{ cm}$
 $\Rightarrow \sin\left(\frac{3\pi}{2} - \alpha\right) = ?$

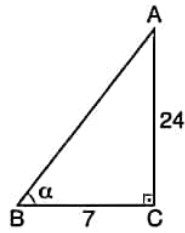

- A) $-\frac{7}{25}$ B) $-\frac{24}{25}$ C) $\frac{7}{25}$ D) $\frac{24}{25}$ E) $\frac{25}{7}$

24. $\lim_{x \rightarrow 0^-} (2^x + 3^{\frac{1}{x}} - 1) = ?$

- A) $-\infty$ B) -1 C) 0 D) 1 E) ∞

25. $\lim_{x \rightarrow 0} \frac{\cos 2x - 1}{\cos x - 1} = ?$

- A) -4 B) -2 C) 0 D) 2 E) 4

26. $f(x) = [1 + (x^2 - x + 1)^2] \Rightarrow f'(0) = ?$

- A) -8 B) -4 C) 0 D) 4 E) 8

K
U
A
R
K
Y
A
Y
I
N
L
A
R
IK
U
A
R
K
P
U
B
L
I
C
A
T
I
O
N
S

YÖS

6

27.

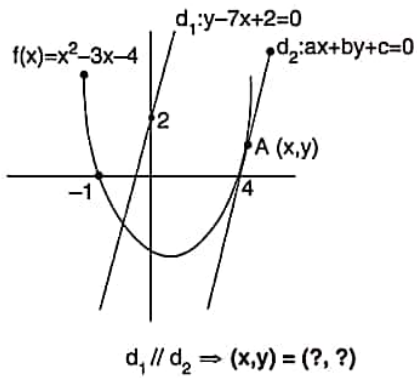

- A) (6, 6) B) (6, 5) C) (5, 5)
- D) (4, 6) E) (5, 6)

28. $\int \frac{x^2}{2} \cdot \frac{dx}{e^x} = ?$

- A) $\frac{1}{2} e^{-x}(x^2 + 2x + 1) + C$
- B) $e^{-x}(x^2 + 2x + 2) + C$
- C) $-\frac{1}{2} e^{-x}(x^2 + 2x + 2) + C$
- D) $-e^{-x}(x^2 - 2x + 2) + C$
- E) $\frac{1}{2} e^{-x}(-x^2 - 2x + 2) + C$

29.

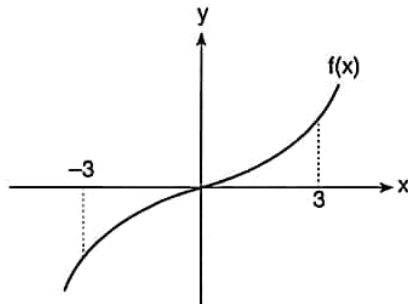

$f(x)$ tek fonksiyondur. / $f(x)$ is an odd function.

$\int_0^3 f(x) dx = 6 \Rightarrow TA/SA = ?br^2(u^2)$

- A) 0 B) 6 C) 9 D) 12 E) 15

30. $A = \begin{bmatrix} 0 & -2 \\ 3 & 1 \end{bmatrix}, B = \begin{bmatrix} -1 & 2 \\ 0 & 1 \end{bmatrix}, C = \begin{bmatrix} -1 & 0 \\ 0 & 4 \end{bmatrix}$

$\Rightarrow A \cdot C + B \cdot C = ?$

- A) $\begin{bmatrix} 0 & 1 \\ 3 & 8 \end{bmatrix}$ B) $\begin{bmatrix} 1 & 0 \\ -3 & 8 \end{bmatrix}$ C) $\begin{bmatrix} 1 & 0 \\ 3 & 8 \end{bmatrix}$
- D) $\begin{bmatrix} 1 & 0 \\ -3 & -8 \end{bmatrix}$ E) $\begin{bmatrix} 0 & 1 \\ -3 & 8 \end{bmatrix}$

K U A R K Y A Y I N L A R I

K U A R K P U B L I C A T I O N S

31.

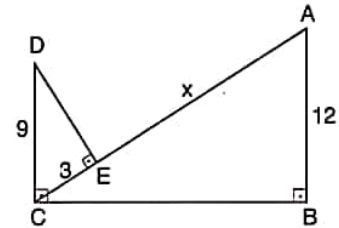

$[DC] \perp [BC], [DE] \perp [AC], [AB] \perp [BC], |DC| = 9 \text{ cm},$

$|EC| = 3 \text{ cm}, |AB| = 12 \text{ cm} \Rightarrow |AE| = x = ? \text{ cm}$

- A) 16 B) 21 C) 24 D) 30 E) 33

YÖS

6

32.

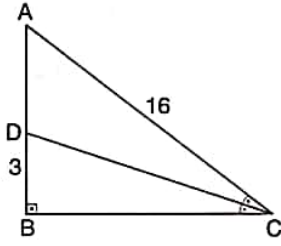

$[AB] \perp [BC]$, $m(\widehat{ACD}) = m(\widehat{DCB})$, $|AC| = 16$ cm,

$|BD| = 3$ cm

$\Rightarrow A(\widehat{ADC}) = ?$ cm²

- A) 14 B) 18 C) 20 D) 24 E) 26

34.

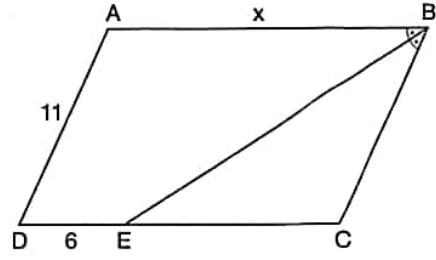

$m(\widehat{ABE}) = m(\widehat{EBC})$, $[AB] \parallel [DC]$, $[AD] \parallel [BC]$,

$|AD| = 11$ cm, $|DE| = 6$ cm $\Rightarrow |AB| = x = ?$ cm

- A) 10 B) 12 C) 16 D) 17 E) 18

33.

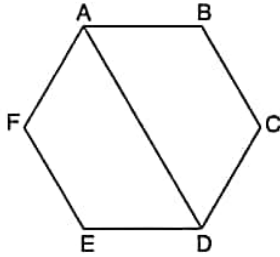

ABCDEF bir düzgün altıgendir.

ABCDEF is regular hexagon.

$|AD| = 16$ cm

\Rightarrow Çevre / The Perimeter (ABCDEF) = ? cm

- A) 36 B) 40 C) 48 D) 52 E) 96

35.

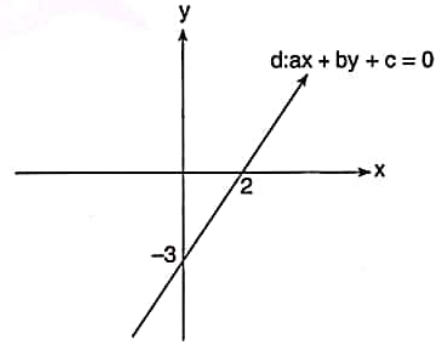

$\Rightarrow d = ?$

- A) $2x - 3y = 0$
 B) $-2x + 3y - 6 = 0$
 C) $3x - 2y - 6 = 0$
 D) $-3x + 2y - 8 = 0$
 E) $2x + 3y - 6 = 0$

YÖS

6

36, 37, 38 ve 39. sorularda I. gruptaki her bir harf, rakam veya şekil, II. gruptaki farklı birer harf, rakam veya şekil ile gösterilmiştir. Buna göre, soru işaretleriyle belirtilen harfleri, rakamları veya şekilleri bulunuz. In questions 36, 37, 38 and 39 each letter, numeral or figure in group I stand for a different letter, numeral or figure in group II. Accordingly, find the letters, numerals or figures which the questions mark stands for.

36.

I.	II.
T İ R E	8 4 7 3
R A M E	6 3 7 2
N U R İ	5 2 6 4
R E T A	7 1 5 2
M E T U	7 2 6 1

⇒ METU = ?

- A) 8473 B) 6372 C) 5264 D) 7152 E) 7261

37.

I.	II.
K E M E R	8 1 7 3 8
N A R İ N	9 2 5 2 7
N İ R A N	7 2 5 2 9
R E M E K	8 3 7 1 8
T A N A İ	6 1 8 1 3

⇒ TANAI = ?

- A) 83718 B) 72529 C) 92527
D) 81738 E) 61813

38.

I.	II.
9 8 0 3 2	♥ ▲ ⊕ * ✓
2 3 8 0 4	♥ ● ■ ▲ *
9 3 1 2 5	✓ ▲ ⊕ * ■
5 3 4 2 0	* ▲ ● ■ ⊕
0 7 1 3 9	■ ⊕ ⊕ ▲ ♥

⇒ 93125 = ?

- A) ♥ ▲ ⊕ * ✓ B) ♥ ● ■ ▲ *
C) ■ ⊕ ⊕ ▲ ♥ D) ✓ ▲ ⊕ * ■
E) * ▲ ● ■ ⊕

39.

I.	II.
3 4 2 5 2	↑ ⊕ → ↑ ○
0 3 4 2 6	⊕ ↑ ○ → ○
6 3 5 8 9	▲ ⊕ → ← Ω
9 0 8 2 5	✓ ⊕ ↑ ○ ▲
4 3 5 4 2	Ω ✓ ← ○ →

⇒ ↑ ⊕ → ← Ω = ?

- A) 38592 B) 43958 C) 43589
D) 43859 E) 35928

K
U
A
R
K
Y
A
Y
I
N
L
A
R
IK
U
A
R
K
P
U
B
L
I
C
A
T
I
O
N
S

YÖS

6

40. I. $6 \circ 4 = 28$
 II. $5 \circ 3 = 19$
 III. $7 \circ 7 = 35$
 IV. $8 \circ 1 = ?$

Yukarıdaki eşitliklerde \circ işaretinin görevi verilmiştir. Buna göre, dördüncü eşitlikteki soru işaretinin yerine aşağıdaki sayılardan hangisi gelmelidir?

In the equations above, the function of \circ is given. Accordingly, which of the following numbers does the question mark stand for in the fourth equation?

- A) 60 B) 61 C) 62 D) 63 E) 64

42. I. $(x-2) \blacktriangle y^2 = x+y-2$
 II. $x \circ y = x \cdot y$
 III. $(3 \blacktriangle 16) \circ 5 = ?$

Yukarıdaki eşitliklerde \blacktriangle ve \circ işaretlerinin görevleri verilmiştir. Buna göre, üçüncü eşitlikteki soru işaretinin yerine aşağıdaki sayılardan hangisi gelmelidir?

In the equations above, the functions of \blacktriangle and \circ are given. Accordingly, which of the following numbers does the question mark stand for in the third equation?

- A) 20 B) 25 C) 30 D) 35 E) 40

41. I. $\frac{(x\Delta y) \cdot 2}{x+y} = \frac{y}{2}$

II. $5 \Delta 6 = ?$

Yukarıdaki birinci eşitlikte Δ işaretinin görevi verilmiştir. Buna göre, ikinci eşitlikteki soru işaretinin yerine aşağıdaki sayılardan hangisi gelmelidir?

In the first equation above, the function of Δ is given. Accordingly, which of the following numbers does the question mark stand for in the second equation?

- A) $\frac{21}{2}$ B) 11 C) $\frac{31}{2}$ D) $\frac{33}{2}$ E) $\frac{35}{2}$

43. I. $x \blacktriangle y = \begin{cases} y^2 & , x \cdot y > 0 \\ x-y & , x \cdot y < 0 \end{cases}$

II. $(3 \blacktriangle 1) \blacktriangle (-2) = ?$

Yukarıdaki birinci eşitlikte \blacktriangle işaretinin görevi verilmiştir. Buna göre, ikinci eşitlikteki soru işaretinin yerine aşağıdaki sayılardan hangisi gelmelidir?

In the first equation above, the function of \blacktriangle is given. Accordingly, which of the following numbers does the question mark stand for in the second equation?

- A) -5 B) -2 C) 1 D) 3 E) 5

K
U
A
R
K
Y
A
Y
I
N
L
A
R
IK
U
A
R
K
P
U
B
L
I
C
A
T
I
O
N
S

44, 45, 46 ve 47. sorulardaki verilen işlemlerde her harf sıfırdan ve birbirinden farklı birer rakamı göstermektedir. Buna göre, soru işareti ile belirtilen harf ya da işlemin değerini bulunuz.

In the operations which are given in questions 44, 45, 46 and 47 each letter stands for a different non-zero numeral. Accordingly, find the value of the letter or operation indicated by the questions mark.

$$44. \quad \begin{array}{r} \text{FFB} \\ - \text{BF} \\ \hline 9F \end{array} \Rightarrow \text{BF} = ?$$

- A) 21 B) 32 C) 43 D) 34 E) 65

$$45. \quad \begin{array}{r} \text{K} \\ - \text{L} \\ \hline 2 \end{array} \quad \begin{array}{r} \text{L} \\ - \text{M} \\ \hline 2 \end{array} \Rightarrow \begin{array}{r} \text{KML} \\ - \text{MKK} \\ \hline ? \end{array}$$

- A) 308 B) 358 C) 395
D) 398 E) 200

$$46. \quad \begin{array}{r} \text{A4} \\ \times \text{4B} \\ \hline \text{2C6} \\ + \text{B6} \\ \hline \text{11E6} \end{array} \Rightarrow \text{A+B+C} = ?$$

- A) 10 B) 11 C) 12 D) 13 E) 14

$$47. \quad \begin{array}{r} 4AB \overline{) AB} \\ - \quad \quad \quad \\ \hline 8 \end{array} \Rightarrow \text{B} - \text{A} = ?$$

- A) 0 B) 1 C) 2 D) 3 E) 4

YÖS

6

48.

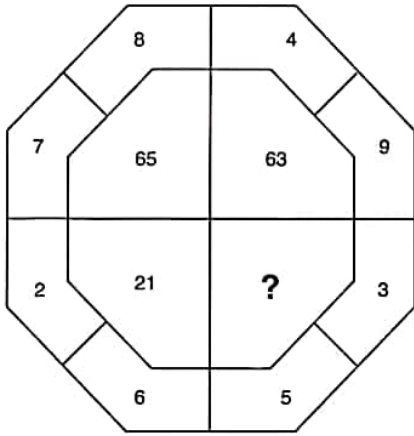

Yukarıdaki sayı-şekil ilişkisine göre soru işaretinin yerine aşağıdaki sayılardan hangisi gelmelidir?

Which of the following numbers does the question mark stand for, according to the number-figure relation above?

- A) 8 B) 15 C) 23 D) 34 E) 51

49.

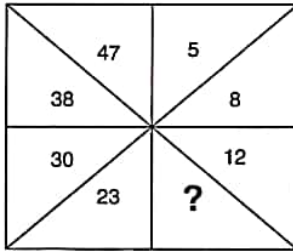

Yukarıdaki sayı-şekil dizisine göre soru işaretinin yerine aşağıdaki sayılardan hangisi gelmelidir?

Which of the following number does the question mark stand for, according to the number-figure sequence above?

- A) 13 B) 15 C) 17 D) 19 E) 21

50.

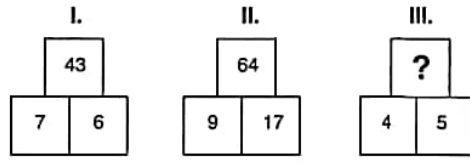

I. ve II. şekillerde verilen kurala göre, III. şekildeki soru işaretinin yerine aşağıdaki sayılardan hangisi gelmelidir?

Which of the following numbers does the question mark stand for in figure III, in accordance with the rule established in figure I and II?

- A) 11 B) 12 C) 13 D) 14 E) 15

51.

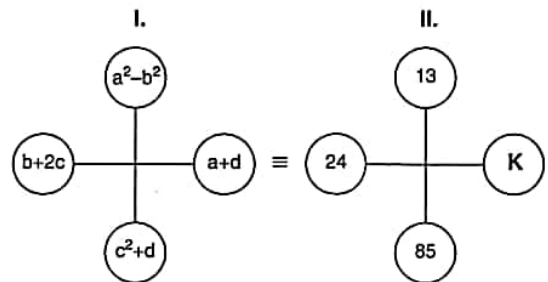

Yukarıdaki I. şekilde verilen işlemler II. şekildeki sayılara eşit olduğuna göre, K kaçtır?

If the letters in figure I are equal to the numbers in figure II above, what is the value of K?

- A) 10 B) 11 C) 12 D) 13 E) 14

K U A R K Y A Y I N L A R I

K U A R K P U B L I C A T I O N S

52.

+	a	b	c
a		4ab	
b			6bc
c	8ac		

$$\Rightarrow a = ?$$

Yukarıdaki toplama tablosunda a, b ve c harfleri pozitif birer sayının yerine kullanılmıştır. Buna göre, a kaçtır?

In the summation table above, the letters a, b and c each stands for a positive number. Accordingly, what is the value of a?

- A) $\frac{1}{6}$ B) $\frac{1}{5}$ C) $\frac{1}{4}$ D) $\frac{1}{3}$ E) $\frac{1}{2}$

53.

x	a	b	c
a			
b		a^6	128
c			a^8

$$\Rightarrow a = ?$$

Yukarıdaki çarpma tablosunda a, b ve c harfleri pozitif birer tam sayının yerine kullanılmıştır. Buna göre, a kaçtır?

In the multiplication table above, the letters a, b and c each stands for a positive integer. Accordingly, what is the value of a?

- A) 8 B) 6 C) 4 D) 3 E) 2

54.

+	a	b	c
a			3-a
b		3-a	
c			

$$\Rightarrow c = ?$$

Yukarıdaki toplama ve çarpma tablolarında a, b ve c harfleri pozitif birer tam sayının yerine kullanılmıştır. Buna göre, c kaçtır?

In the summation and multiplication tables above, the letters a, b and c each stands for a positive integer. Accordingly, what is the value of c?

- A) 20 B) 22 C) 24 D) 26 E) 28

55.

+	a	b	c
a		22	2b
b			
c			

$$\Rightarrow a + b + c = ?$$

Yukarıdaki toplama ve çarpma tablolarında a, b ve c harfleri pozitif birer tam sayının yerine kullanılmıştır. Buna göre, a + b + c kaçtır?

In the summation and multiplication tables above, the letters a, b and c each stands for a positive integer. Accordingly, what is the value of a + b + c?

- A) 36 B) 38 C) 40 D) 42 E) 44

YÖS

6

56.

						Sonuç (Result)
□	☆	○	□	□	□	
☆	△	☆	□	○	△	
□	□	□	△	☆	□	
△	□	△	○	□	?	
○	☆	○	△	□	□	

Yukarıdaki tabloya göre soru işaretinin yerine hangi şekil gelmelidir?

According to the table above, which of the figure does the question mark stand for?

- A) △ B) ○ C) □ D) ☆ E) □

57.

	○□	☆△	△○
☆□	□□	?	□○
△○	○□	○△	○○

Yukarıdaki tabloya göre soru işaretinin yerine hangi şekiller gelmelidir?

According to the table above, which of the figures does the question mark stand for?

- A) ○△ B) ☆△ C) □△
D) □☆ E) ☆☆

58.

	☉	☽	☾
41	17	y	17
52	x	9	29
74	53	23	z

$$\Rightarrow z - y - x = ?$$

Yukarıdaki tabloya göre $z - y - x$ kaçtır?

According to the table above, what is the value of $z - y - x$?

- A) 30 B) 31 C) 32 D) 33 E) 34

59.

I	x	2	2
II	2	2	y
III	2	z	2

$$\Rightarrow x = ? ; y = ? ; z = ?$$

Yukarıdaki tabloya göre x , y ve z kaçtır?

According to the table above, what are the value of x , y and z , respectively?

- A) 1; 3; 2 B) 1; 2; 3 C) 1; 3; 3
D) 1; 2; 2 E) 3; 2; 1

K U A R K Y A Y I N L A R I

K U A R K P U B L I C A T I O N S

60.

						Sonuç (Result)
□	△	□	○	△	○	
○	□	△	□	○	□	
□	○	□	△	△	△	
△	□	△	○	□	K	
△	□	L	○	□		Sonuç (Result)

$$\Rightarrow K = ? ; L = ?$$

Yukarıdaki tabloya göre K ve L aşağıdakilerden hangisidir?

According to the table above, which of the following stands for K and L?

- A) □; ○ B) □; □ C) ○; △
D) □; △ E) △; △

61.

		I	II	III
△	△	K	○	○
○	○	□	□	L
○	○	□	□	M

$$\Rightarrow K = ? ; L = ? ; M = ?$$

Yukarıdaki tabloya göre K, L ve M aşağıdakilerden hangisidir?

According to the table above, which of the following stands for K, L and M?

- | | K | L | M |
|----|---|---|---|
| A) | △ | □ | ○ |
| B) | △ | ○ | △ |
| C) | △ | ○ | △ |
| D) | △ | ○ | △ |
| E) | △ | ○ | △ |

K U A R K Y A Y I N L A R I

K U A R K P U B L I C A T I O N S

YÖS

6

62, 63, 64 ve 65. sorularda, verilen her bir şekil matrisindeki soru işaretinin yerine hangi şeklin getirilmesi gerektiğini bulunuz.

In questions 62, 63, 64 and 65, find the figure which should replace the question mark in each given figure matrix.

62.

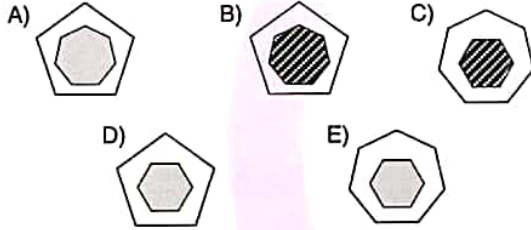
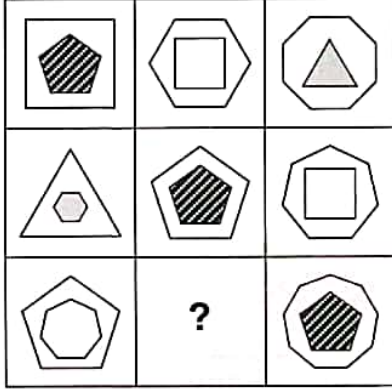

63.

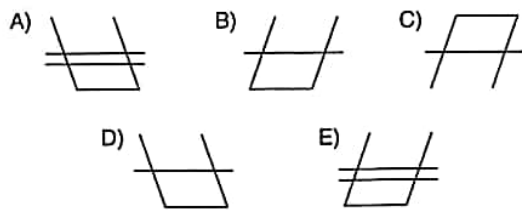
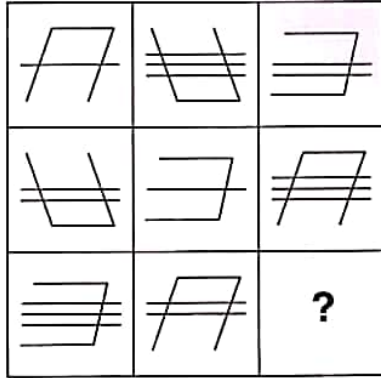

64.

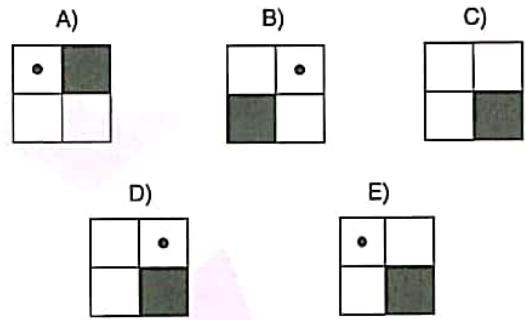
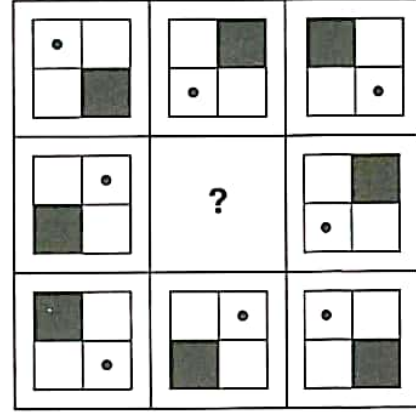

65.

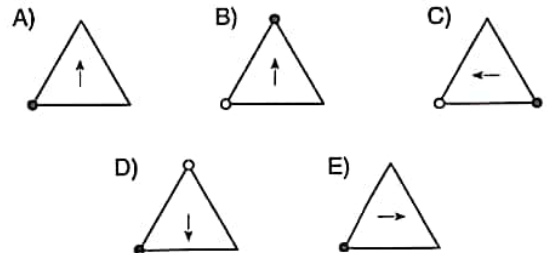
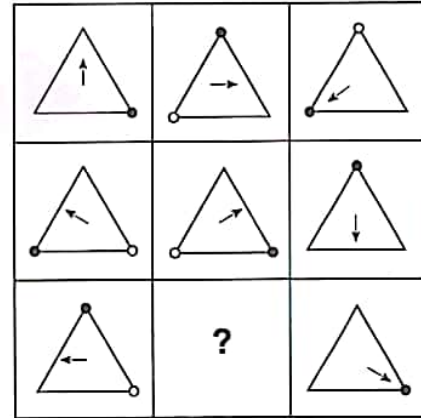

K U A R K Y A Y I N L A R I

K U A R K P U B L I C A T I O N S

66 ve 67. sorularda, I. satırda belirlenen ilişkiye göre II. satırı hangi şeklin tamamladığını bulunuz.

In questions 66 and 67, find the figure which completes row II, in accordance with the relation established in row I.

66.

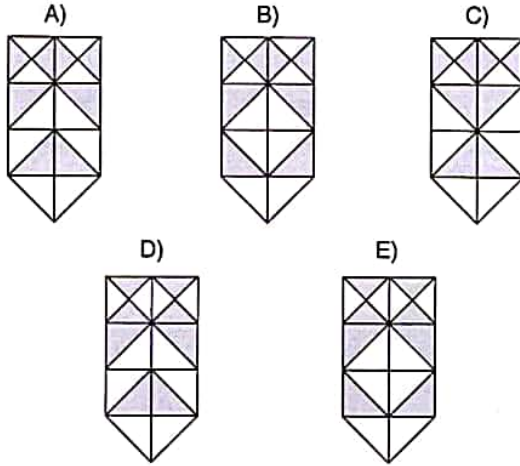
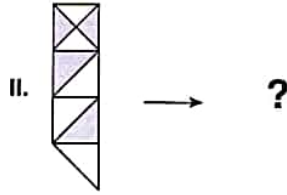
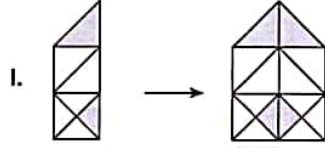

67.

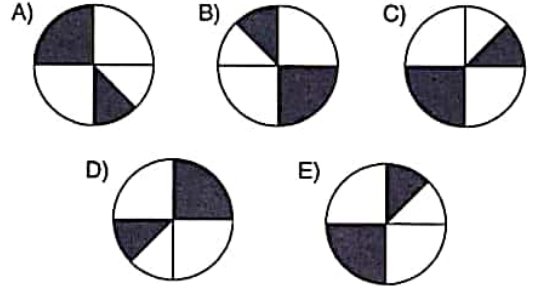
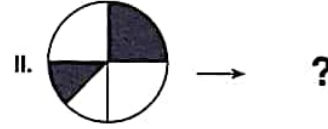
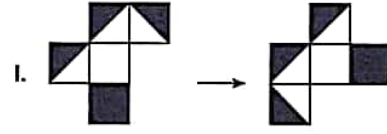

68.

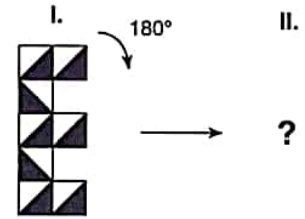

Yukarıdaki şekil aynı düzlem üzerinde ok yönünde 180° döndürülürse aşağıdaki şekillerden hangisi oluşur?

If the figure above is rotated through 180° in the direction of the arrow on the same plane, which of the following figures is obtained?

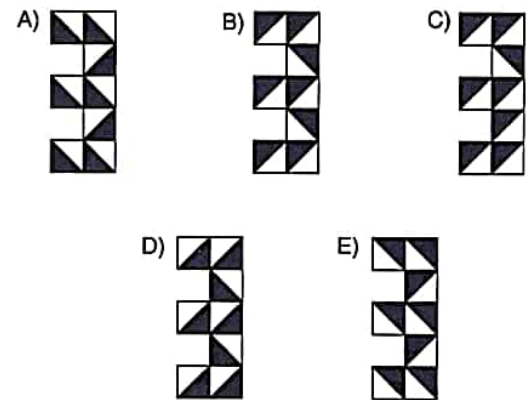

YÖS

6

69, 70 ve 71. sorularda, verilen her bir şekil dizisindeki soru işaretinin yerine hangi şeklin getirilmesi gerektiğini bulunuz.

In questions 69, 70 and 71 find the figure which should replace the question mark in each given figure sequence.

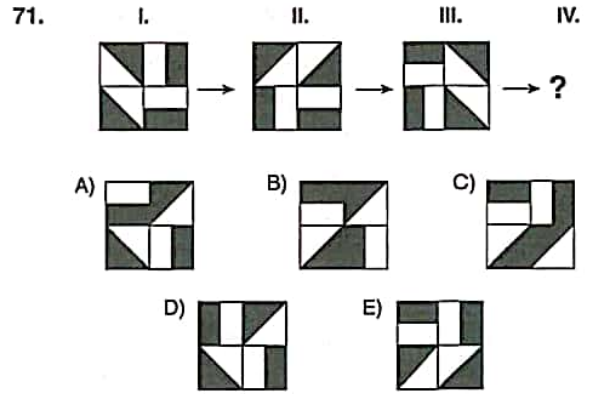
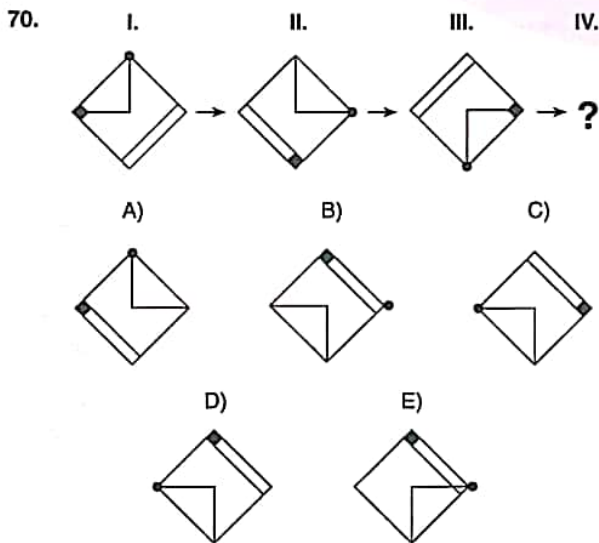
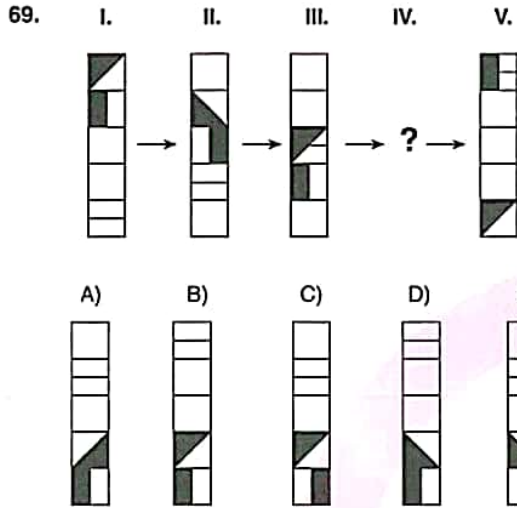

72. soruda, soru işaretinin yerine getirilmesi gereken şekli bulunuz.

In question 72, find the figure to replace the question mark.

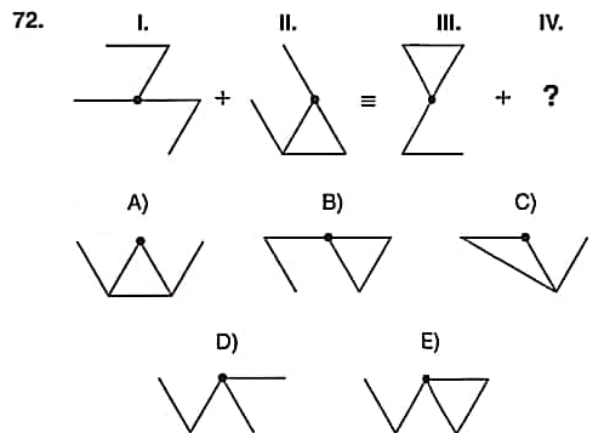

YÖS

6

73.

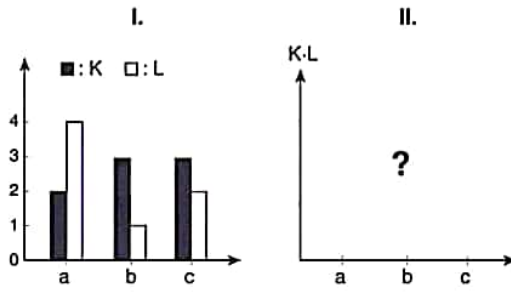

Yukarıdaki birinci sütun grafikte verilen bilgilere göre, ikinci grafik aşağıdakilerden hangisidir?

According to the information in the first column chart above, which of the following does the second chart stand for?

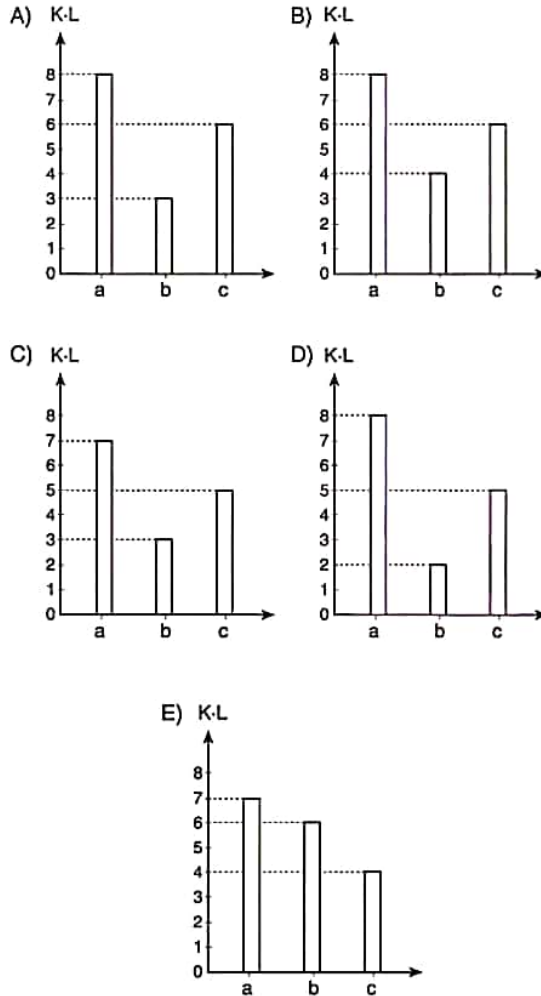

74.

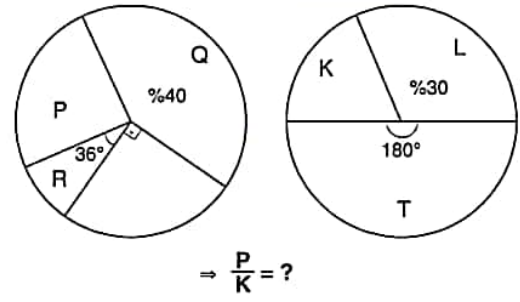

Yukarıdaki dairesel grafiklere göre, $\frac{P}{K}$ kaçtır?

According to the circular charts above, what is the value of $\frac{P}{K}$?

- A) $\frac{9}{4}$ B) $\frac{5}{4}$ C) $\frac{3}{2}$ D) 1 E) $\frac{4}{7}$

75.

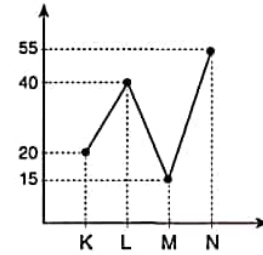

$$K + L + M + N = 260 \Rightarrow M = ?$$

Yukarıdaki çizgi grafikte verilen bilgilere göre, M kaçtır?

According to the information in the line chart above, what is the value of M?

- A) 30 B) 40 C) 60 D) 80 E) 110

YÖS

6

76. soruyu aşağıdaki örnekte verilen ilişkiye göre cevaplayınız.

Answer question 76, in accordance with the relation established in the example below.

ÖRNEK / EXAMPLE:

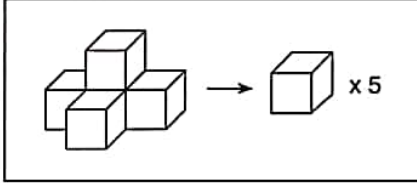

77 ve 78. soruları aşağıdaki örnekte verilen ilişkiye göre cevaplayınız.

Answer questions 77 and 78, in accordance with the relation established in the example below.

ÖRNEK / EXAMPLE:

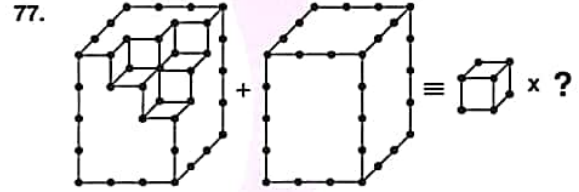
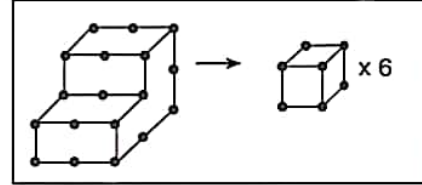

- A) 70 B) 69 C) 68 D) 67 E) 66

76.

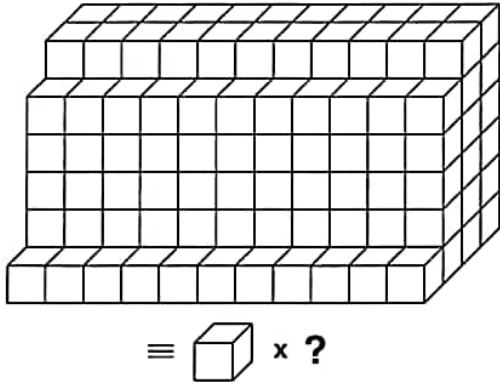

- A) 192 B) 194 C) 196 D) 198 E) 200

78.

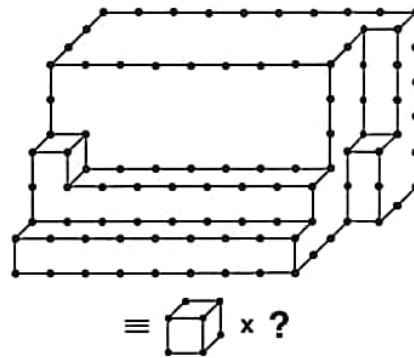

- A) 150 B) 151 C) 152 D) 153 E) 154

KUARK YAYINLARI

KUARK PUBLICATIONS

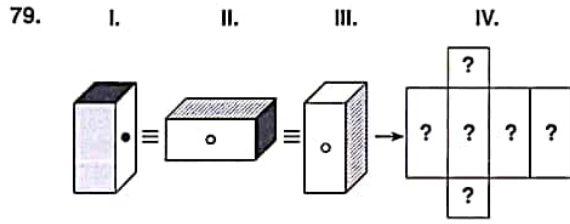

Yukarıdaki şekillerin tümü aynı prizmayı göstermektedir. Buna göre, aşağıdakilerden hangisi bu prizmanın açılmış halidir?

The figures represent the same prism above. Accordingly, which of the following represents the unfolded form of this prism?

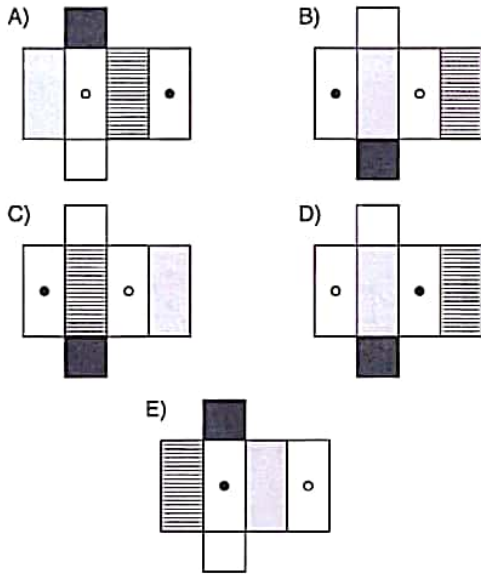

80.

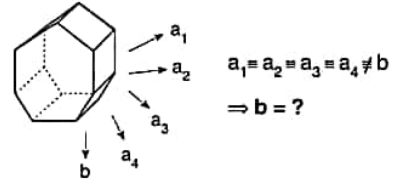

Aşağıdakilerden hangisi yukarıda verilen nesnenin açılımlarından biri değildir?

Which of the following does not represent the unfolded form of the object given above?

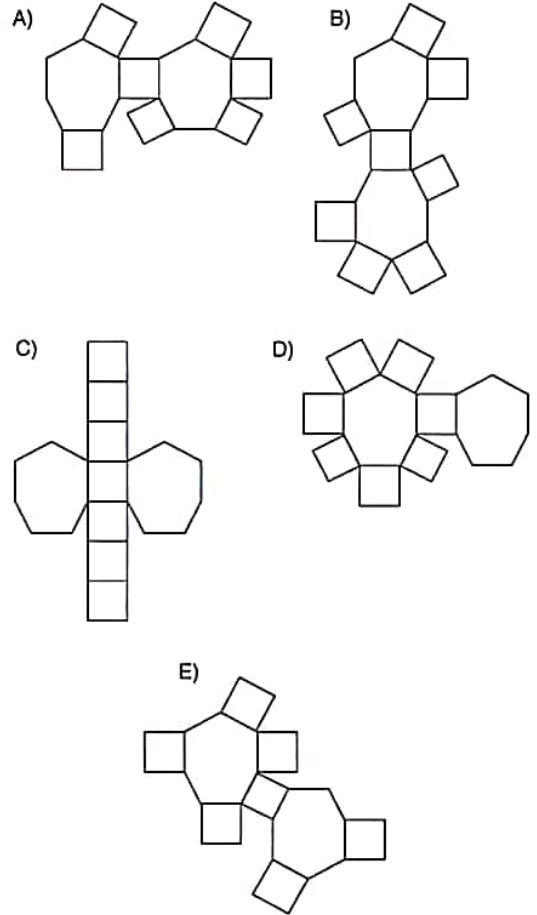

1, 2, 3 ve 4. sorularda I. gruptaki her bir harf, rakam veya şekil, II. gruptaki farklı birer harf, rakam veya şekil ile gösterilmiştir. Buna göre, soru işaretiyle belirtilen harfleri, rakamları veya şekilleri bulunuz.

In questions 1, 2, 3 and 4 each letter, numeral or figure in group I stand for a different letter, numeral or figure in group II. Accordingly, find the letters, numerals or figures which the questions mark stands for.

1.

I.	II.
P O J	6 7 3
P O B	4 7 6
P A H	3 7 6
T A P	6 1 9
H A P	6 1 5

⇒ TAP = ?

- A) 673 B) 476 C) 376 D) 619 E) 615

2.

I.	II.
E V R İ M	8 4 5 1 3
E V R E N	2 1 5 4 7
K E R İ M	4 6 5 1 3
D İ R E N	4 6 5 4 7
D İ R İ M	2 1 5 1 3

⇒ EVRİM = ?

- A) 84513 B) 21547 C) 46513
D) 46547 E) 21513

3.

I.	II.
A M A C	8 3 7 9
C A R K	3 4 3 5
K A S A	5 3 7 2
K U R S	2 1 7 8
S A R I	2 3 8 3

⇒ SARI = ?

- A) 8379 B) 3435 C) 5372 D) 2178 E) 2383

4.

I.	II.
→ ↑ ↓ ⊖	⇒ ?
⊖ ↑ → ⊖	
↑ ⊖ ↓ ↑	
⊖ → ● ↑	

- A)

B	T	N	T
F	T	B	T
T	F	N	F
F	B	U	F
- B)

B	T	N	B
F	T	B	F
T	F	N	T
F	B	U	T
- C)

B	T	N	F
F	T	B	F
T	F	N	T
F	B	U	T
- D)

B	T	N	T
F	T	B	F
T	F	N	T
F	B	U	T
- E)

B	T	N	F
F	T	E	F
T	F	N	T
T	E	U	F

5, 6 ve 7. sorulardaki verilen işlemlerde her harf sıfırdan ve birbirinden farklı birer rakamı göstermektedir. Buna göre, soru işareti ile belirtilen harf ya da işlemin değerini bulunuz.

In the operations which are given in questions 5, 6 and 7 each letter stands for a different non-zero numeral. Accordingly, find the value of the letter or operation indicated by the question mark.

$$5. \quad \begin{array}{r} K \\ + L \\ \hline MM \end{array} \quad \begin{array}{r} K \\ - L \\ \hline N \end{array} \Rightarrow \min(N) = ?$$

- A) 1 B) 2 C) 3 D) 4 E) 5

$$6. \quad \begin{array}{r} K 6 3 \\ + L L L \\ \hline 8 M 6 \end{array} \Rightarrow K + M = ?$$

- A) 8 B) 10 C) 12 D) 14 E) 16

$$7. \quad \begin{array}{r} L K L \\ + L K K \\ \hline K K M \end{array} \Rightarrow M = ?$$

- A) 2 B) 3 C) 4 D) 8 E) 9

K
U
A
R
K
Y
A
Y
I
N
L
A
R
I

K
U
A
R
K
P
U
B
L
I
C
A
T
I
O
N
S

$$8. \quad \begin{array}{l} \text{I. } x \blacktriangle y = x + y^2 \\ \text{II. } x \blacksquare y = x + 1 + y \\ \text{III. } x \bullet y = 2x - y \\ \text{IV. } (3 \blacktriangle 4) \blacksquare 5) \bullet 1 = ? \end{array}$$

Yukarıdaki eşitliklerde \blacktriangle , \blacksquare ve \bullet işaretlerinin görevleri verilmiştir. Buna göre, dördüncü eşitlikteki soru işaretinin yerine aşağıdaki sayılardan hangisi gelmelidir?

In the equations above, the functions of \blacktriangle , \blacksquare and \bullet are given. Accordingly, which of the following numbers does the question mark stand for in the fourth equation?

- A) 48 B) 49 C) 50 D) 51 E) 52

YÖS

7

9. I. $3(a \square b) = 2a + b$

II. $5 \square 8 = ?$

Yukarıdaki birinci eşitlikte \square işaretinin görevi verilmiştir. Buna göre, ikinci eşitlikteki soru işaretinin yerine aşağıdaki sayılardan hangisi gelmelidir?

In the first equation above, the function of \square is given.

Accordingly, which of the following numbers does the question mark stand for in the second equation?

- A) 5 B) 6 C) 7 D) 8 E) 9

11. I. $91 \square 84 = 18$

II. $82 \square 63 = 8$

III. $62 \square 11 = 3$

IV. $51 \square 99 = ?$

Yukarıdaki eşitliklerde \square işaretinin görevi verilmiştir. Buna göre, dördüncü eşitlikteki soru işaretinin yerine aşağıdaki sayılardan hangisi gelmelidir?

In the equations above, the function of \square is given.

Accordingly, which of the following numbers does the question mark stand for in the fourth equation?

- A) 5 B) 10 C) 20 D) 40 E) 45

K
U
A
R
K
Y
A
Y
I
N
L
A
R
IK
U
A
R
K
P
U
B
L
I
C
A
T
I
O
N
S

10. I. $x^2 \triangle (y - 2) = y(x - 2)$

II. $9 \triangle 5 = ?$

Yukarıdaki birinci eşitlikte \triangle işaretinin görevi verilmiştir. Buna göre, ikinci eşitlikteki soru işaretinin yerine aşağıdaki sayılardan hangisi gelmelidir?

In the first equation above, the function of \triangle is given. Accordingly, which of the following numbers does the question mark stand for in the second equation?

- A) 5 B) 6 C) 7 D) 8 E) 9

12.

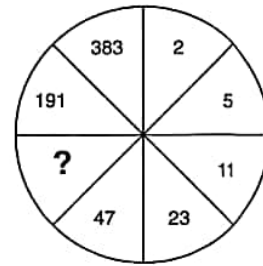

Yukarıdaki sayı-şekil dizisine göre soru işaretinin yerine aşağıdaki sayılardan hangisi gelmelidir?

Which of the following numbers does the question mark stand for, according to the number-figure sequence above?

- A) 89 B) 91 C) 93 D) 95 E) 97

13.

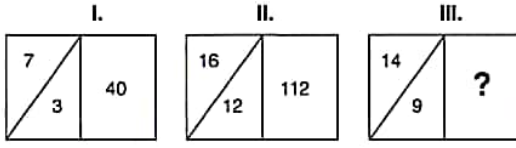

I. ve II. şekillerde verilen kurala göre, III. şekildeki soru işaretinin yerine aşağıdaki sayılardan hangisi gelmelidir?

Which of the following numbers does the question mark stand for in figure III, in accordance with the rule established in figures I and II?

- A) 99 B) 95 C) 92 D) 90 E) 89

14.

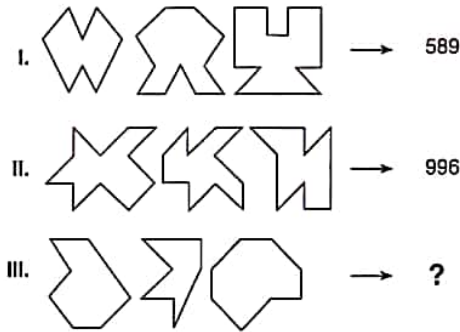

I. ve II. satırlarda belirlenen ilişkiye göre, III. satırı aşağıdaki sayılardan hangisi tamamlar?

Which of the following numbers completes III, in accordance with the relation established in I and II?

- A) 345 B) 454 C) 445 D) 443 E) 554

15.

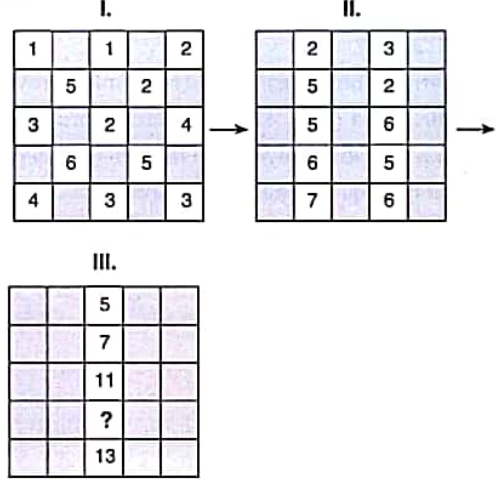

Yukarıdaki sayı-şekil dizisine göre soru işaretinin yerine aşağıdaki sayılardan hangisi gelmelidir?

Which of the following numbers does the question mark stand for, according to the number-figure sequence above?

- A) 11 B) 12 C) 13 D) 14 E) 15

16.

+	a	b	c
a			
b	18		17
c	15		

$$\Rightarrow a + b + c = ?$$

Yukarıdaki toplama tablosunda a, b ve c harfleri pozitif birer tam sayının yerine kullanılmıştır. Buna göre, $a + b + c$ kaçtır?

In the summation table above, the letters a, b and c each stands for a positive integer. Accordingly, what is the value of $a + b + c$?

- A) 25 B) 30 C) 35 D) 45 E) 50

17.

x	a	b	c
a			$\frac{b}{2}$
b	32-c		
c		8-a	

$$\Rightarrow b + c = ?$$

Yukarıdaki çarpma tablosunda a, b ve c harfleri pozitif birer tam sayının yerine kullanılmıştır. Buna göre, b + c kaçtır?

In the multiplication table above, the letters a, b and c each stands for a positive integer. Accordingly, what is the value of b + c?

- A) 6 B) 10 C) 14 D) 18 E) 22

18.

+	a	b	c
a			
b			25
c			2·(a + b)













$$\Rightarrow c = ?$$

Yukarıdaki toplama ve çarpma tablolarında a, b ve c harfleri pozitif birer tam sayının yerine kullanılmıştır. Buna göre, c kaçtır?

In the summation and multiplication tables above, the letters a, b and c each stands for a positive integer. Accordingly, what is the value of c?

- A) 5 B) 10 C) 15 D) 20 E) 25

19.

			
			
		4x + 1	4x
		Kx + L	3x + 2
		4x + 3	3x + 7
			K + 3L

$$\Rightarrow K + L = ?$$

Yukarıdaki tabloya göre K + L kaçtır?

According to the table above, what is the value of K + L ?

- A) 8 B) 9 C) 10 D) 11 E) 12

YÖS

7

20.

	I	II	III
□ ○ △ △ □ ○	□ ○ □ △ ○ □	△ □ △ □ △ ○	M
□ ○ △ ○ □ △	△ □ □ □ ○ ○	L	△ □ △ ○ ○ ○
△ ○ △ □ □ △	K	△ △ □ □ △ △	○ △ □ △ ○ △

⇒ K = ? ; L = ? ; M = ?

Yukarıdaki tabloda K, L ve M nedir?

In the table above, what is the value of K, L and M?

	K	L	M
A)	□ □ ○ □ △ △	□ △ ○ △ △ □	○ ○ △ △ □ ○
B)	□ □ ○ △ △ △	□ △ ○ ○ △ ○	△ ○ △ □ □ △
C)	○ □ □ □ △ △	△ △ ○ △ △ □	○ ○ △ △ □ ○
D)	□ □ ○ △ □ △	□ △ ○ ○ △ △	○ △ △ ○ □ △
E)	○ ○ ○ □ △ △	□ △ ○ △ △ ○	○ ○ △ □ □ △

21.

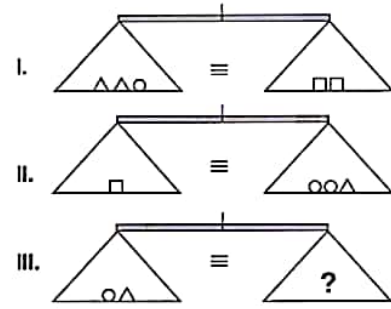

Yukarıdaki terazilerin üçü de dengededir. Buna göre, III. terazideki soru işaretini aşağıdakilerden hangisi göstermektedir?

All three scales above are in balance. Accordingly, which of the following does the question mark stand for in the third scale?

- A) □ □ B) △ △ C) △ □ D) □ □ E) □ ○ ○

22.

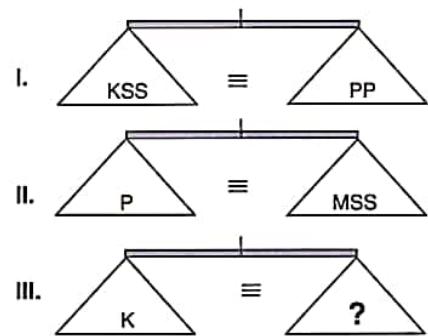

Yukarıdaki terazilerin üçü de dengededir. Buna göre, III. terazideki soru işaretini aşağıdakilerden hangisi göstermektedir?

All three scales above are in balance. Accordingly, which of the following does the question mark stand for in the third scale?

- A) MS B) MP C) P D) MSS E) MMS

K U A R K Y A Y I N L A R I

K U A R K P U B L I C A T I O N S

YÖS

7

23, 24 ve 25. sorularda, verilen her bir şekil matrisindeki soru işaretinin yerine hangi şeklin getirilmesi gerektiğini bulunuz.

In questions 23, 24 and 25, find the figure which should replace the question mark in each given figure matrix.

23.

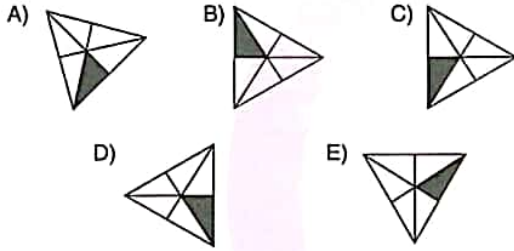
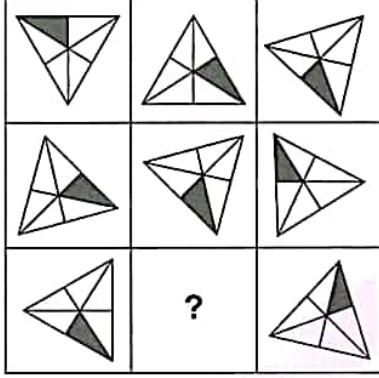

24.

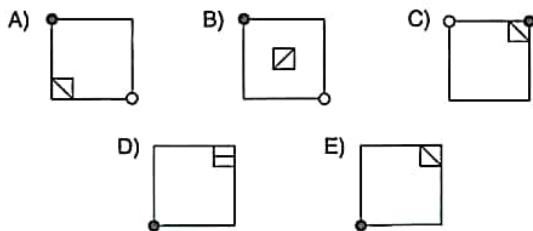
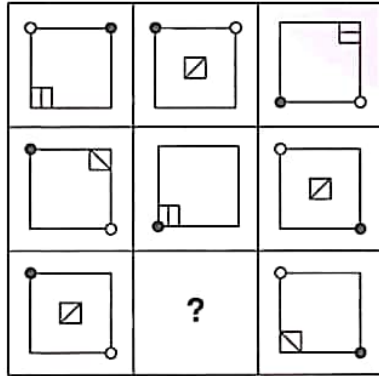

25.

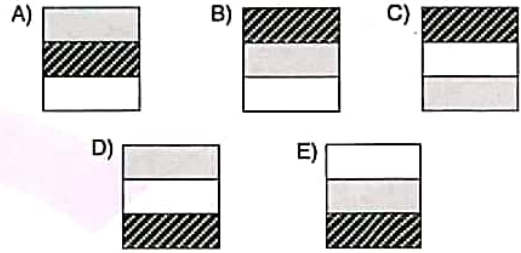
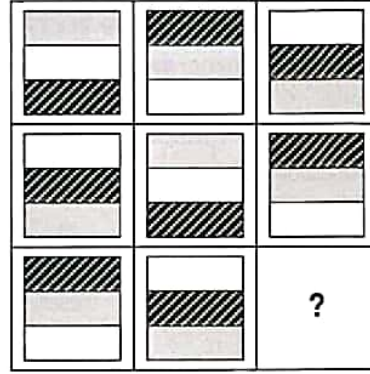

K U A R K Y A Y I N L A R I

K U A R K P U B L I C A T I O N S

YÖS

7

26 ve 27. sorularda, verilen her bir şekil dizisindeki soru işaretinin yerine hangi şeklin getirilmesi gerektiğini bulunuz.

In questions 26 and 27, find the figure which should replace the question mark in each given figure sequence.

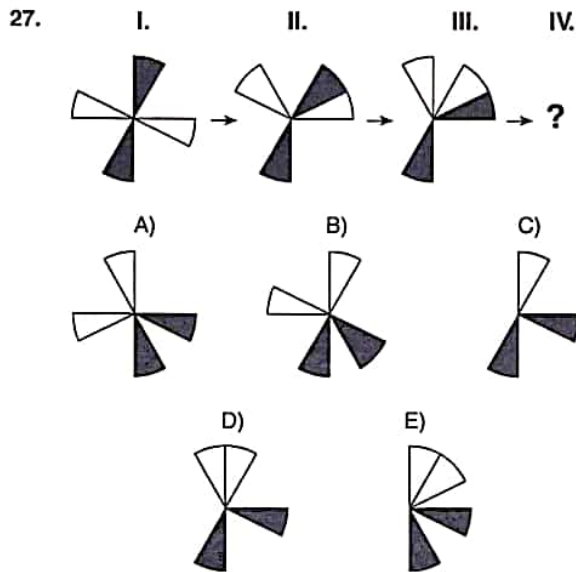
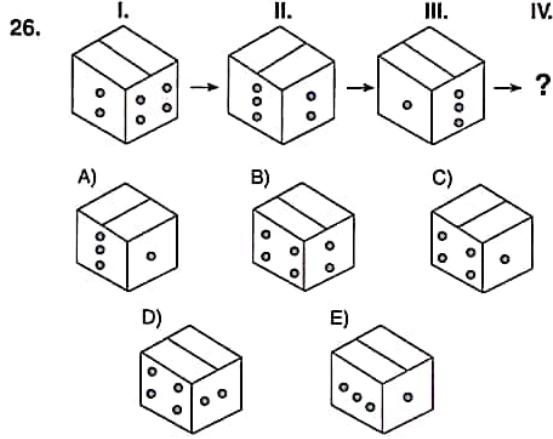

28, 29 ve 30. sorularda, I. satırda belirlenen ilişkiye göre II. satırı hangi şeklin tamamladığını bulunuz.

In questions 28, 29 and 30, find the figure which completes row II, in accordance with the relation in row I.

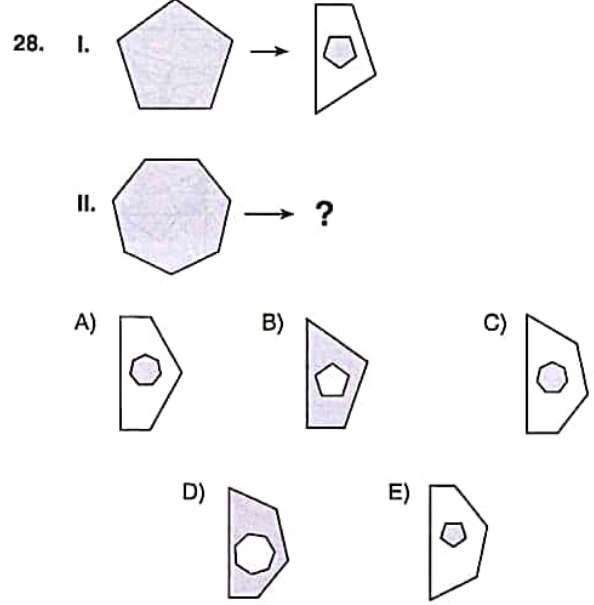

K U A R K Y A Y I N L A R I

K U A R K P U B L I C A T I O N S

YÖS

7

29.

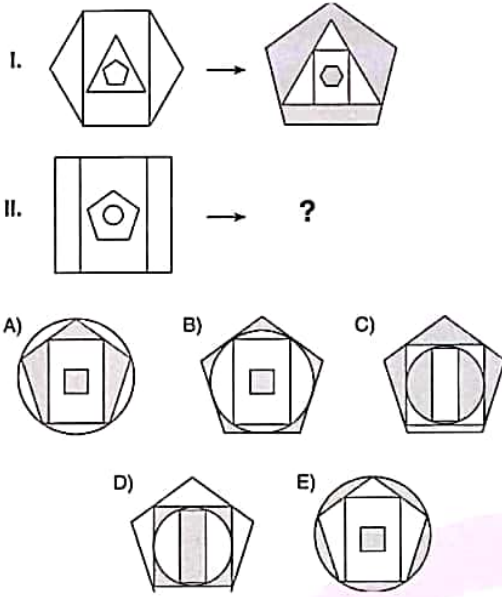

30.

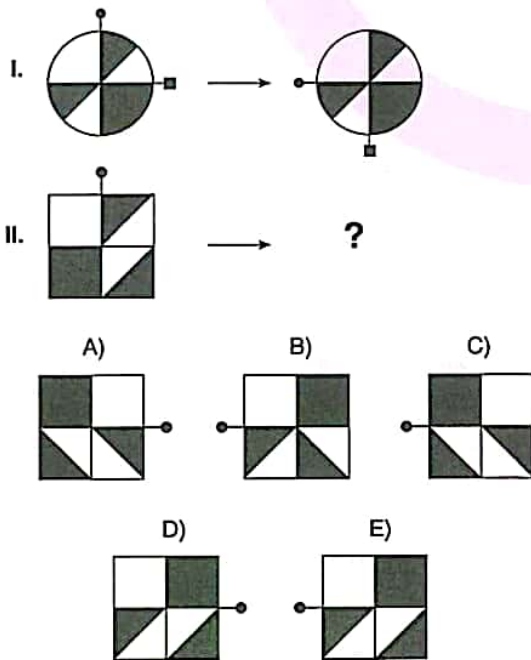

31 ve 32. soruları aşağıdaki örnekte verilen ilişkiye göre cevaplayınız.

Answer questions 31 and 32, in accordance with the relation established in the example below.

ÖRNEK / EXAMPLE:

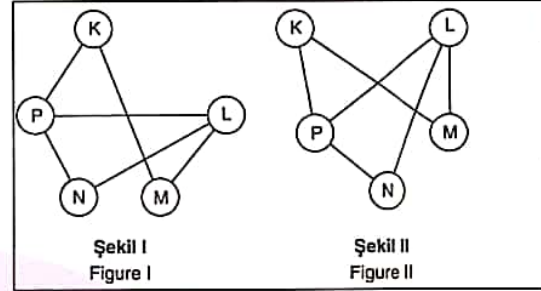

K, L, M, N ve P harfleri I. şekildeki gibi birbirine bağlanmıştır. I. şekildeki bağlantı sayıları ve birbirine bağlanan harfler değişmemek koşuluyla II. şekil elde edilmiştir.

The letters K, L, M, N and P are linked as in Figure I. Figure II has been constructed on condition that the number of links and letters connected in figure I do not change.

31.

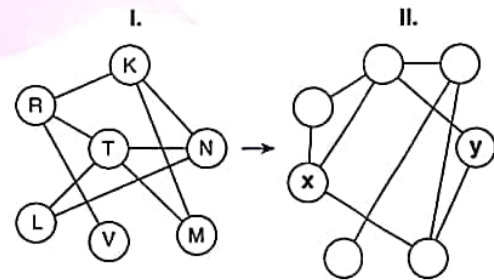

⇒ x ; y = ?

	x	y
A)	N	L
B)	N	M
C)	R	M
D)	K	L
E)	R	V

YÖS

7

32.

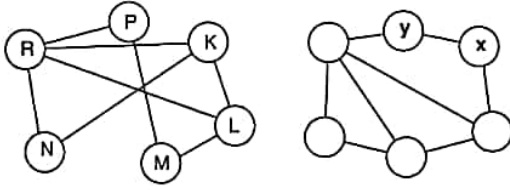
 $\Rightarrow x=?; y=?$

	x	y
A)	N	L
B)	N	M
C)	R	M
D)	K	L
E)	M	P

33.

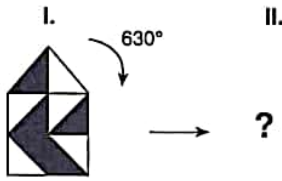

Yukarıdaki şekil aynı düzlem üzerinde ok yönünde 630° döndürülürse aşağıdaki şekillerden hangisi oluşur?

If the figure above is rotated through 630° in the direction of the arrow on the same plane, which of the following figures is obtained?

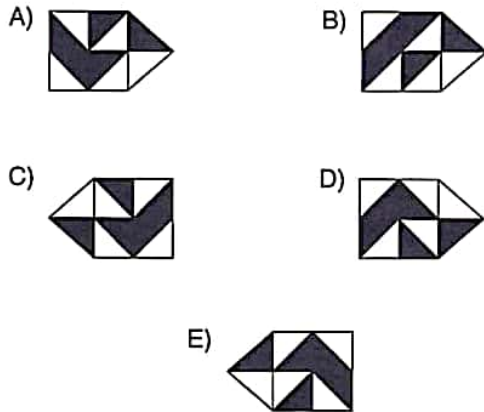

34.

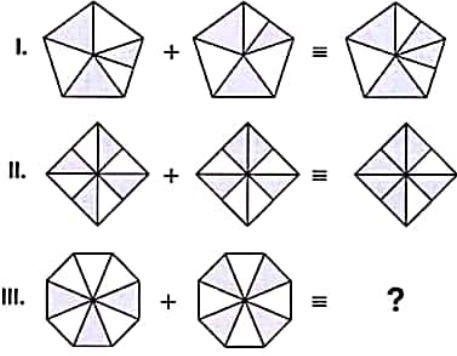

I ve II. satırda belirlenen ilişkiye göre III. satırı hangi şeklin tamamladığını bulunuz.

Find the figure which completes row III, in accordance with the relation established in rows I and II.

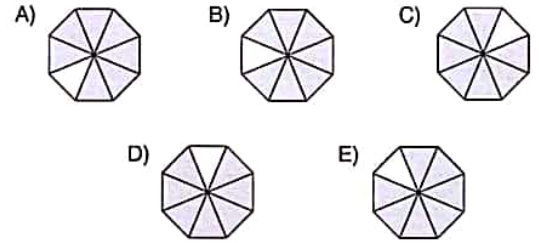

35.

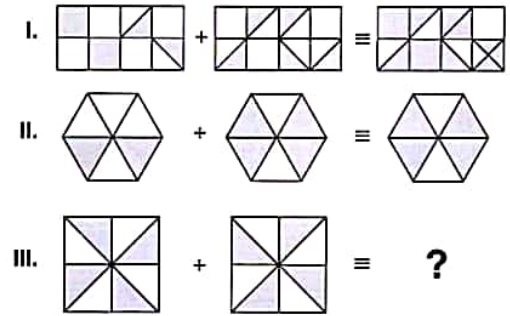

I ve II. satırda belirlenen ilişkiye göre III. satırı hangi şeklin tamamladığını bulunuz.

Find the figure which completes row III, in accordance with the relation established in row I and II.

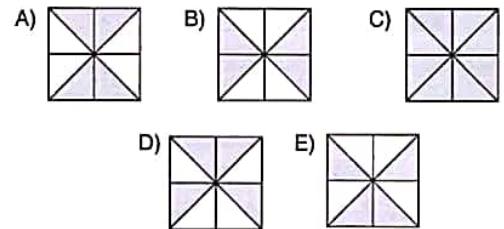

YÖS

7

36 ve 37. soruları aşağıdaki örnekte verilen ilişkiye göre cevaplayınız.

Answer questions 36 and 37, in accordance with the relation established in the example below.

ÖRNEK / EXAMPLE:

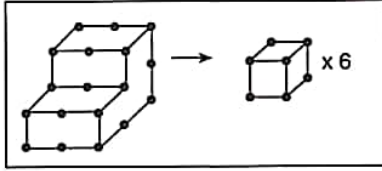

36.

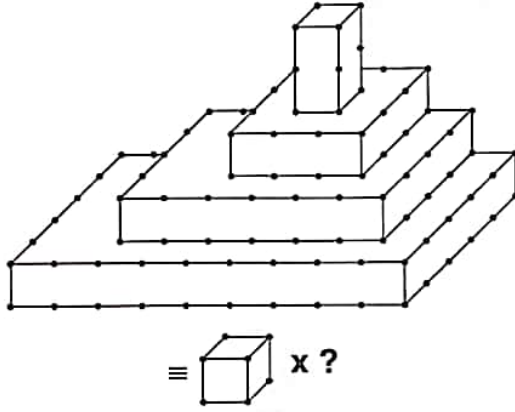

A) 79 B) 80 C) 81 D) 82 E) 83

37.

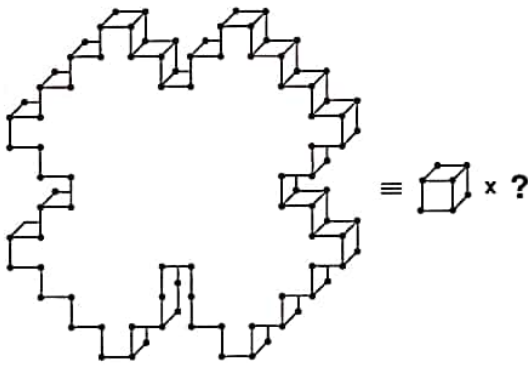

A) 76 B) 77 C) 78 D) 79 E) 80

38.

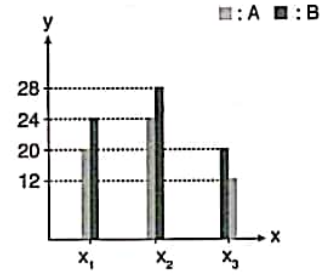

$$\Rightarrow x_1A + x_2B + x_3A + x_1B = ?$$

Yukarıdaki sütun grafikte verilen bilgilere göre, $x_1A + x_2B + x_3A + x_1B$ kaçtır?

According to the information in the column chart above, what is the value of $x_1A + x_2B + x_3A + x_1B$?

A) 72 B) 75 C) 78 D) 81 E) 84

39.

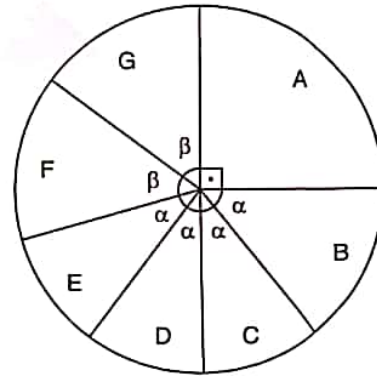

$$\Rightarrow F + E + D = ?$$

Yukarıdaki dairesel grafikte verilen bilgilere göre, $F + E + D$ kaç derecedir?

According to the information in the circular chart above, what is the degree of $F + E + D$?

A) 90° B) 105° C) 120° D) 135° E) 150°

K U A R K Y A Y I N L A R I

K U A R K P U B L I C A T I O N S

YÖS

7

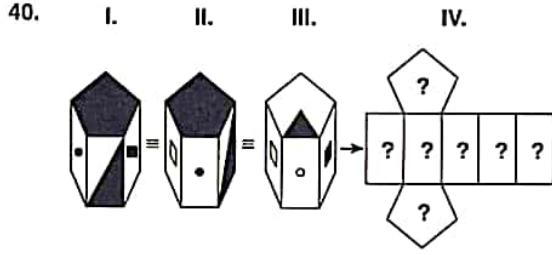

Yukarıdaki şekiller aynı nesneyi göstermektedir. Buna göre bu nesnenin açılmış hali aşağıdakilerden hangisidir?

The figures above represent the same object. Accordingly, which of the following represent the unfolded form of this object?

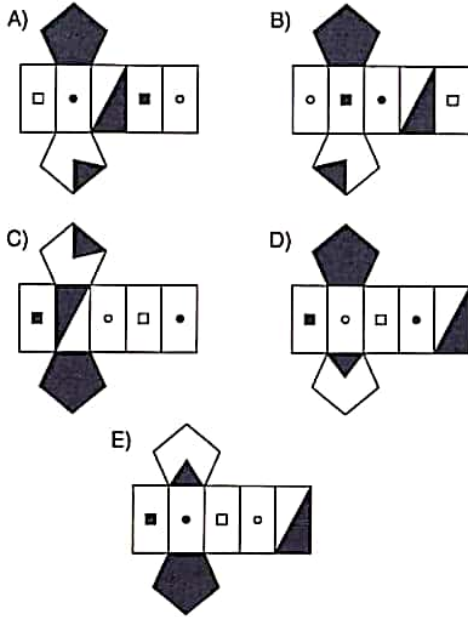

41. ABCD bir yamuktur.
ABCD is a trapezoid.
[AB] // [DC],
 $m(\widehat{ABD}) = m(\widehat{DBC})$,
IDBI = 10 cm,
IBCI = 13 cm
 $\Rightarrow A(\widehat{BDC}) = ? \text{ cm}^2$

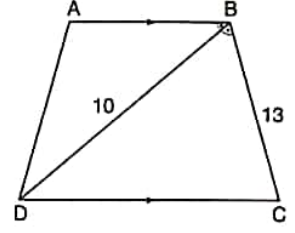

- A) 40 B) 45 C) 50 D) 55 E) 60

K U A R K Y A Y I N L A R I

K U A R K P U B L I C A T I O N S

42.

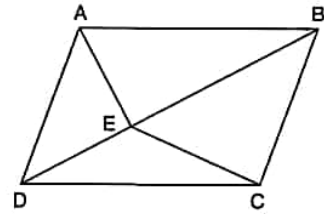

ABCD bir paralelkenardır. / ABCD is a parallelogram.

$$A(ABCD) = 56 \text{ cm}^2$$

\Rightarrow Taralı Alan / The Shaded Area = ? cm^2

- A) 14 B) 18 C) 28 D) 32 E) 40

YÖS

7

43.

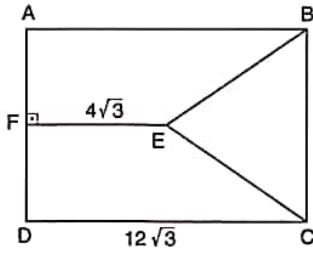

ABCD bir dikdörtgen, BEC eşkenar üçgendir.

ABCD is a rectangle, BEC is an equilateral triangle.

$[EF] \perp [AD] \Rightarrow A(ABCD) = ? \text{ cm}^2$

- A) 27 B) 36 C) $48\sqrt{3}$
D) $96\sqrt{3}$ E) $192\sqrt{3}$

45.

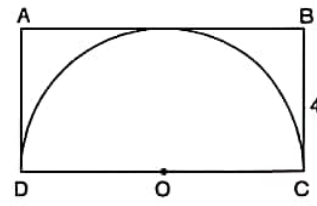

O noktası şekildeki yarım çemberin merkezidir.

The point O is center of the semicircle in the figure.

$IBCI = 4 \text{ cm} \Rightarrow \text{Taralı Alan / The Shaded Area} = ? \text{ cm}^2$

- A) $16 - 6\pi$ B) $32 - 4\pi$ C) $32 - 8\pi$
D) $32 - 16\pi$ E) $16 - 4\pi$

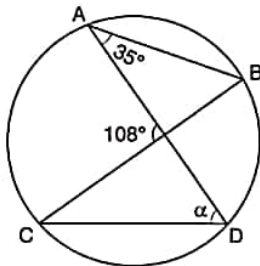
K
U
A
R
K
Y
A
Y
I
N
L
A
R
IK
U
A
R
K
P
U
B
L
I
C
A
T
I
O
N
S44. $\alpha = ?$ 

- A) 62° B) 64° C) 68° D) 70° E) 73°

46. $IDEI \parallel IACI$
 $IBEI = IBDI = IECI$
 $m(\widehat{ECA}) = 30^\circ$
 $\Rightarrow m(\widehat{ABD}) = ?$

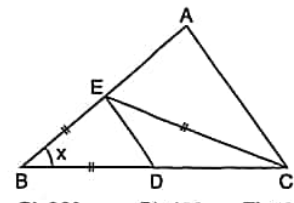

- A) 10° B) 20° C) 30° D) 40° E) 50°

YÖS

7

47. $\vec{A} = (-4, -2, x - 1)$

$\vec{B} = (-4, y + 1, 4)$

$\vec{A} = \vec{B} \Rightarrow x + y = ?$

- A) 1 B) 2 C) 3 D) 4 E) 5

49. $10 + 12 + 14 + 16 + \dots + K = 400$

$\Rightarrow K = ?$

- A) 20 B) 26 C) 32 D) 36 E) 40

K
U
A
R
K
Y
A
Y
I
N
L
A
R
IK
U
A
R
K
P
U
B
L
I
C
A
T
I
O
N
S

48. $x, y, z \in \mathbb{N}$,

$2x + 3y + z = 37$

$\Rightarrow \max(x) = ?$

- A) 10 B) 15 C) 16 D) 18 E) 19

50. $\frac{1\frac{2}{5} - 2\frac{1}{5} + 1}{5^{-1}} = ?$

- A) -1 B) 0 C) 1 D)
- $\frac{1}{5}$
- E) 25

YÖS

7

51. $A = \frac{2}{5} + \frac{1}{3} - \frac{3}{4} \Rightarrow \frac{3}{5} + \frac{2}{3} - \frac{1}{4} = ?$

- A) $-A$ B) $-1 - A$ C) $1 - A$
D) $1 + A$ E) $2A - 1$

53. $\frac{x^2 - xy^2 + x^2y - xy}{x + xy} = ?$

- A) x B) $y - x$ C) $x - y$
D) $x + y$ E) $x + xy$

K
U
A
R
K
Y
A
Y
I
N
L
A
R
IK
U
A
R
K
P
U
B
L
I
C
A
T
I
O
N
S

52. $A = \sqrt{93} - \sqrt{57}$
 $B = \sqrt{104} - \sqrt{46}$
 $C = \sqrt{79} - \sqrt{71}$
 $\Rightarrow ? < ? < ?$

- A) $B > A > C$ B) $C > A > B$ C) $A > B > C$
D) $C > B > A$ E) $A > C > B$

54. Dönüm Fiyatı (Price of Decare)

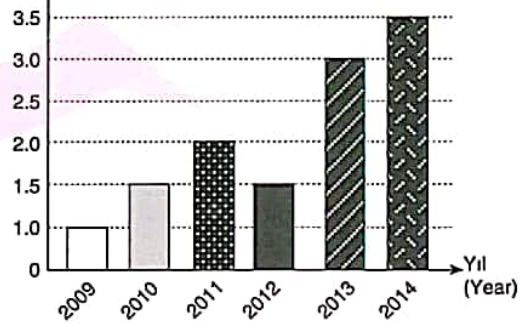

Yukarıdaki grafiğe göre; dönüm fiyatlarındaki en fazla değişim hangi yıllar arasında yaşanmıştır?

According to the graph above between which years was the greatest change in the price of decare?

- A) 2009 ve(and) 2010
B) 2010 ve(and) 2011
C) 2011 ve(and) 2012
D) 2012 ve(and) 2013
E) 2013 ve(and) 2014

55. $\sqrt{9+\sqrt{32}} \cdot (4\sqrt{2}-2) = ?$
 A) $2\sqrt{2}$ B) 8 C) $2\sqrt{7}$ D) 14 E) 16

58. $x \in \mathbb{Z}$,
 $2x - 1 \leq x + 4 < 3x + 2 \Rightarrow \sum x = ?$
 A) 5 B) 8 C) 0 D) 14 E) 15

K
U
A
R
K
Y
A
Y
I
N
L
A
R
I

56. $\frac{a}{4} = \frac{b}{5} = \frac{c}{7}$, $a+b+c=32 \Rightarrow a = ?$
 A) 4 B) 8 C) 10 D) 14 E) 20

59. $x \in \mathbb{Z}$
 $-2 < |x-3| \leq 5$
 $\Rightarrow \text{ÇK(SS)} = ?$
 A) (1,5) B) [-2,8] C) (-2,8]
 D) (1,8] E) [-2,5)

K
U
A
R
K
P
U
B
L
I
C
A
T
I
O
N
S

57. $\frac{6x-8}{3-x} + \frac{6-2x}{x-3} = 2 \Rightarrow x = ?$
 A) 2 B) 4 C) 6 D) 8 E) 10

60. $A \in \mathbb{N}$
 OBEB(GCF) (24, 84, A) = 12
 OKEK(LCM) (24, 84, A) = 840
 $\Rightarrow \min(A) = ?$
 A) 48 B) 52 C) 56 D) 60 E) 72

YÖS

7

61. Bir sınıfta 3'ü yeşil gözlü 8 kız ve 4'ü yeşil gözlü 10 erkek öğrenci vardır. Bu sınıftan seçilen bir öğrencinin kız veya yeşil gözlü olma olasılığı kaçtır?
There are 8 girls such that 3 of them have green eyes and 10 boys such that 4 of them have green eyes in a classroom. What is the probability of choosing a green-eyed student from among the classroom?

A) $\frac{1}{3}$ B) $\frac{2}{3}$ C) $\frac{5}{18}$ D) $\frac{7}{18}$ E) $\frac{5}{6}$

K U A R K Y A Y I N L A R I

63. $f(x) = \begin{cases} 1, & x \equiv 0 \pmod{5} \\ x+1, & x \equiv 1 \pmod{5} \\ 1-x, & x \equiv 2 \pmod{5} \end{cases} \Rightarrow (f \circ f)(6) + f(20) = ?$

A) -5 B) -3 C) 6 D) 12 E) 21

64. $P(x)$ bir polinom ise; / if $P(x)$ is a polynomial;

$$P(x) = (a-4)x^{\sqrt{2}} + (b-3)x^{\frac{1}{2}} + x^2 - x^{a-b}$$

$$\Rightarrow \text{der}[P(x)] = ?$$

A) $\frac{1}{2}$ B) $2\sqrt{2}$ C) 2 D) 4 E) 12

K U A R K P U B L I C A T I O N S

62.

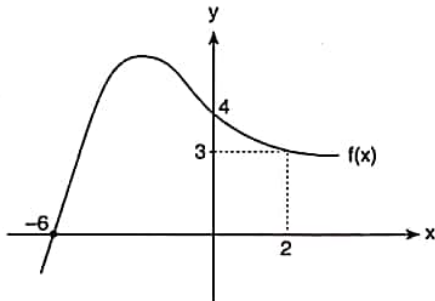

$$(f \circ f)(2x + 1) = 4 \Rightarrow x = ?$$

A) -4 B) $-\frac{7}{2}$ C) -3 D) 3 E) 4

65. $\sqrt{x+1} - 1 = x$, $\text{ÇK}(SS) = \{x_1, x_2\}$
 $\Rightarrow \sum x = ?$

A) -2 B) -1 C) 0 D) 1 E) 2

YÖS

7

66. $\log_x y = 2,$
 $\ln y^3 = 9 \Rightarrow x = ?$

- A) \sqrt{e} B) e C) $e\sqrt{e}$ D) e^2 E) e^3

67. $\log_4 [2 \cdot \log_3 (3 \cdot \log_2 (x-1))] = 1 \Rightarrow x = ?$

- A) 3 B) 6 C) 7 D) 9 E) 12

68. $i = \sqrt{-1},$

$$P(x) = 2x^{13} - 3x^{11} + 2x^5 + x$$

$$\Rightarrow P(i^7) = ?$$

- A) $-6 - 4i$ B) $-3 - i$ C) $-8i$
 D) $-6 - 7i$ E) $8 - 3i$

69. $\frac{\sin(750^\circ) + \cos(420^\circ)}{\tan(405^\circ) + \cot(150^\circ)} = A \Rightarrow 2A = ?$

- A) $\sqrt{3} + 3$ B) $\frac{\sqrt{3} + 1}{2}$ C) $\frac{\sqrt{3} - 1}{2}$
 D) $-\sqrt{3} - 1$ E) $\frac{-\sqrt{3} - 1}{2}$

K
U
A
R
K
Y
A
Y
I
N
L
A
R
IK
U
A
R
K
P
U
B
L
I
C
A
T
I
O
N
S

70. ABCD bir karedir.
 ABCD is a square.
 $|BE| = |EC|$
 $\Rightarrow \tan(\alpha) = ?$

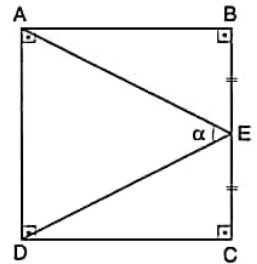

- A) $\frac{1}{2}$ B) $-\frac{4}{3}$ C) $-\frac{3}{4}$ D) $\frac{3}{4}$ E) $\frac{4}{3}$

YÖS

7

$$71. \left. \begin{aligned} A &= \sum_{k=0}^3 k \cdot k! \\ B &= \sum_{k=1}^4 \binom{k}{0} \end{aligned} \right\} \Rightarrow A+B=?$$

- A) 56 B) 48 C) 40 D) 27 E) 24

$$72. f: \mathbb{R} \rightarrow \mathbb{R}$$

$$f(x) = \begin{cases} 5x-8, & x=2 \\ 2x-4, & x \neq 2 \end{cases} \Rightarrow \lim_{x \rightarrow 2} (4+f(x)) = ?$$

- A) 2 B) 4 C) 6 D) 8 E) 10

$$73. \lim_{x \rightarrow 10^+} \left(\frac{|10-x|}{x-10} + x-9 \right) = ?$$

- A) 1 B) 2 C) 3 D) 4 E) 5

$$74. f(x) = \frac{d}{dx} \left(\frac{x^3}{3} - \frac{x^2}{2} - x + 1 \right) \Rightarrow f'(2) = ?$$

- A) 1 B) 3 C) 5 D) 7 E) 9

$$75. \begin{aligned} f(x) &= x^2 + 1, \\ g(x) &= 3x^2 - x - 1 \\ &\Rightarrow \left(\frac{f}{g} \right)'(1) = ? \end{aligned}$$

- A) -8 B) -6 C) -4 D) 2 E) 6

$$76. \int \frac{6x^4 - 2x}{x} dx = ?$$

- A) $6x^4 - 2x + C$
 B) $6x^3 - 2 + C$
 C) $3x^2 - 2x + C$
 D) $\frac{3}{2}x^4 - 2x + C$
 E) $\frac{4}{3}x^4 - x + C$

K
U
A
R
K
Y
A
Y
I
N
L
A
R
IK
U
A
R
K
P
U
B
L
I
C
A
T
I
O
N
S

77. $\int_{\pi/24}^{\pi/8} \cot 4x \, dx = ?$

- A) $-\ln \sqrt{3}$ B) $-\frac{1}{4} \ln 2$ C) $\ln \sqrt{2}$
D) $\frac{1}{4} \ln 2$ E) $\frac{1}{2}$

78.

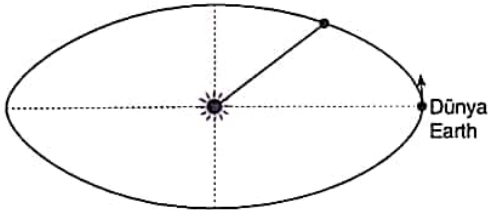

Dünyayı güneşe birleştiren doğru parçası eşit alanlar tarar. Dünya yörüngesini tamamladığında doğru parçasının taradığı alan hangi matematiksel işlem-işlemlerle hesaplanır?

The line segment that bonds the earth and the sun shades equal areas. When the earth finishes its orbit, which mathematical operations can be used to find the shaded region?

I. İntegral (Integral) (\int)

II. Toplam (Sum) ($\sum_{k=0}^n$)

III. Seri (Series) ($\sum_{k=0}^{\infty}$)

- A) Yalnız I B) Yalnız II C) Yalnız III
D) I ve(and) II E) II ve(and) III

79. $A = \begin{bmatrix} 3 & 1 & 2 \\ 4 & -2 & 0 \end{bmatrix}$, $B = \begin{bmatrix} 2 & 1 & 3 \\ 5 & 12 & 1 \end{bmatrix}$
 $B - 2A = C \Rightarrow C = ?$

A) $\begin{bmatrix} -4 & -1 & -1 \\ -3 & -16 & 1 \end{bmatrix}$

B) $\begin{bmatrix} -4 & -1 & -1 \\ -3 & 16 & 1 \end{bmatrix}$

C) $\begin{bmatrix} -4 & -1 & -1 \\ -3 & -16 & 0 \end{bmatrix}$

D) $\begin{bmatrix} 4 & 1 & 1 \\ 3 & -16 & -1 \end{bmatrix}$

E) $\begin{bmatrix} -3 & 16 & 0 \\ -4 & -1 & -1 \end{bmatrix}$

K
U
A
R
K
Y
A
Y
I
N
L
A
R
I

K
U
A
R
K
P
U
B
L
I
C
A
T
I
O
N
S

80. $A = \begin{bmatrix} a & b \\ c & d \end{bmatrix}$, $\det(A) = -5 \Rightarrow \det(A^{-1}) = ?$

- A) -5 B) $-\frac{1}{5}$ C) 0 D) $\frac{1}{5}$ E) 5

1, 2 ve 3. sorularda I. gruptaki her bir harf, rakam veya şekil, II. gruptaki farklı birer harf, rakam veya şekil ile gösterilmiştir. Buna göre, soru işaretiyle belirtilen harfleri, rakamları veya şekilleri bulunuz.

In questions 1, 2 and 3, each letter, numeral or figure in group I stand for a different letter, numeral or figure in group II. Accordingly, find the letters, numerals or figures which the questions mark stands for.

1.

I.	II.	
M U M	}	2 4 2
E L E		7 4 7
S U S		9 4 1
Ş U G		3 0 3
N A B		8 5 6

⇒ NAB = ?

- A) 242 B) 747 C) 941
D) 303 E) 856

2.

I.	II.	
B A N	}	★ ↗ △
Q A N		↗ ○ ★
N A L		↘ ↗ △
A N T		△ ↗ ○
A L Q		↗ △ □

⇒ NAL = ?

- A) ↗ △ □ B) ↗ ○ ★ C) ★ ↗ △
D) ↘ ↗ △ E) △ ↗ ○

3.

I.	II.	
A T R U M K	}	2 7 8 9 4 1
İ U R T N K		1 6 7 4 5 9
A E T U R İ		3 4 7 6 8 9
İ E M T R N		1 2 6 4 7 3
E R N K U A		3 2 5 6 7 8

⇒ KMURTA = ?

- A) 149872 B) 954761 C) 986743
D) 374621 E) 876523

4, 5 ve 6. sorulardaki verilen işlemlerde her harf sıfırdan ve birbirinden farklı birer rakamı göstermektedir. Buna göre, soru işareti ile belirtilen harf ya da işlemin değerini bulunuz.

In the operations which are given in questions 4, 5 and 6 each letter stands for a different non-zero numeral. Accordingly, find the value of the letter or operation indicated by the questions mark.

$\begin{array}{r} KLM \\ -MLK \\ \hline 297 \end{array}$	$\begin{array}{r} KM \\ +MK \\ \hline 121 \end{array}$	⇒ K x M = ?
--	--	-------------

- A) 14 B) 21 C) 28 D) 35 E) 42

YÖS

8

$$5. \begin{array}{r} A B C \\ + B 7 \\ \hline B 2 8 \end{array} \Rightarrow A + B + C = ?$$

- A) 5 B) 6 C) 7 D) 9 E) 12

$$6. \begin{array}{r} K K \\ \times K \\ \hline L L \end{array} + \begin{array}{r} K K \\ + L L \\ \hline M M \end{array} \Rightarrow K + L + M = ?$$

- A) 12 B) 11 C) 10 D) 9 E) 8

7. I. $6 * 7 = 49$
II. $4 * 3 = 15$
III. $5 * 6 = 36$
IV. $4 * 2 = ?$

Yukarıdaki eşitliklerde * işaretinin görevi verilmiştir. Buna göre, dördüncü eşitlikteki soru işaretinin yerine aşağıdaki sayılardan hangisi gelmelidir?

In the equations above, the function of * is given. Accordingly, which of the following numbers does the question mark stand for in the fourth equation?

- A) 6 B) 8 C) 10 D) 12 E) 14

$$8. \text{ I. } a \circ b = 2 \cdot a + b - 1$$

$$\text{II. } a \square b = a + \frac{b}{3}$$

$$\text{III. } (4 \square 9) \circ (6 \square 3) = ?$$

Yukarıdaki eşitliklerde \circ ve \square işaretlerinin görevleri verilmiştir. Buna göre, üçüncü eşitlikteki soru işaretinin yerine aşağıdaki sayılardan hangisi gelmelidir?

In the equations above, the functions of \circ and \square are given. Accordingly, which of the following numbers does the question mark stand for in the third equation?

- A) 20 B) 21 C) 22 D) 23 E) 24

K
U
A
R
K
Y
A
Y
I
N
L
A
R
IK
U
A
R
K
P
U
B
L
I
C
A
T
I
O
N
S

$$9. \text{ I. } a \blacktriangledown b = \frac{a}{b} \circ b^2$$

$$\text{II. } a \circ b = 2a \square \frac{b}{3}$$

$$\text{III. } a \square b = b^a$$

$$\text{IV. } (6 \blacktriangledown 3) + (4 \circ 6) = ?$$

Yukarıdaki eşitliklerde \circ , \square ve \blacktriangledown işaretlerinin görevleri verilmiştir. Buna göre, dördüncü eşitlikteki soru işaretinin yerine aşağıdaki sayılardan hangisi gelmelidir?

In the equations above, the functions of \circ , \square and \blacktriangledown are given. Accordingly, which of the following numbers does the question mark stand for in the fourth equation?

- A) 240 B) 289 C) 337 D) 361 E) 400

YÖS

8

10.

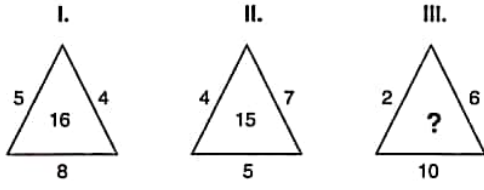

I. ve II. şekillerde verilen kurala göre, III. şekildeki soru işaretinin yerine aşağıdaki sayılardan hangisi gelmelidir?

Which of the following numbers does the question mark stand for in figure III, in accordance with the rule established in figure I and II?

- A) 8 B) 11 C) 12 D) 14 E) 17

11.

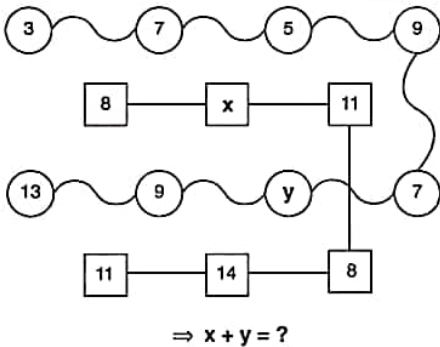

Yukarıdaki sayı-şekil dizilerine göre $x + y$ kaçtır?
What is the value of $x + y$, according to the number-figure sequences above?

- A) 14 B) 15 C) 16 D) 17 E) 18

12.

+	a	b	c
a		c+4	
b			2-a
c	b+4		

$$\Rightarrow a = ?$$

Yukarıdaki toplama tablosunda a, b ve c harfleri pozitif birer tam sayının yerine kullanılmıştır. Buna göre, a kaçtır?

In the summation table above, the letters a, b and c each stands for a positive integer. Accordingly, what is the value of a?

- A) 2 B) 3 C) 4 D) 5 E) 6

13.

☆	8	16	24
4	3	5	B
2	A	9	13
6	—	—	5

$$\Rightarrow A; B = ? ; ?$$

Yukarıdaki tablo ☆ işlemine göre düzenlenmiştir. Buna göre, A ve B nedir?

The tablo above is organized according to the ☆ operation. Accordingly, what is the value of A and B?

- A) — ; 7 B) 3 ; 7 C) 5 ; —
D) 5 ; 7 E) 7 ; 5

K U A R K Y A Y I N L A R I

K U A R K P U B L I C A T I O N S

YÖS

8

14. I. 2 4 6 12 14
 II. 40 20 18 9 7
 III. 3 9 12 36 39
 IV. ? ? ? ? ?

Yukarıdaki I. sayı dizisi ile II. sayı dizisi arasında belli bir ilişki vardır. Buna göre, III. sayı dizisi ile aşağıdaki sayı dizilerinden hangisi arasında benzer bir ilişki vardır?

Number series I and II are related to each other. Accordingly, which of the following number series represent a similar relation to the number series III?

- A) 90 30 27 9 12
 B) 24 21 7 4 7
 C) 63 21 18 6 3
 D) 21 7 13 4 6
 E) 6 10 24 28 42

15.

K	L	M	N
M	R	P	T
P	K	T	P
T	N	L	M

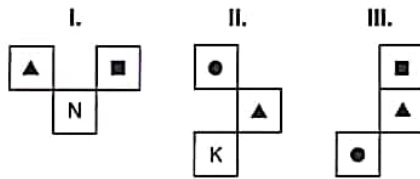

= \triangle ; \square ; \bullet = ?

I, II ve III yukarıdaki tablonun farklı birer parçasıdır.

Buna göre, \triangle , \square ve \bullet aşağıdakilerden hangisidir?

I, II and III are three different parts of the table above.

Accordingly, which of the following does \triangle , \square and \bullet stand for?

- A) R; T; P B) P; T; L C) L; P; T
 D) L; N; R E) T; P; N

16 ve 17. soruları aşağıdaki şekle göre cevaplayınız.
 Answer questions 16 and 17 in accordance with the figure given below.

Her soru birbirinden bağımsız olarak cevaplanacaktır.
 Each question is to be answered independently.

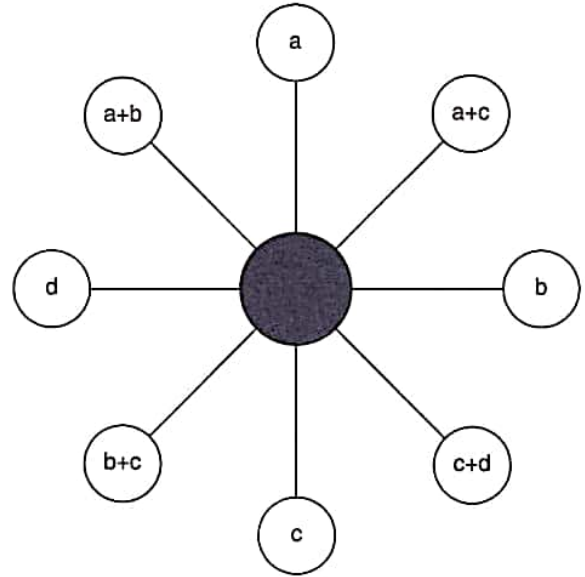

Yukarıdaki şekil a, b, c ve d harfleriyle gösterilen dört pozitif tam sayıyı içeren bazı işlemlere göre düzenlenmiştir. Harflerin gösterdiği sayılar her soruda farklı olabilir; fakat yapılacak işlemler her soruda aynıdır.

The figure above has been organized according to various operations using four positive integers represented by the letters a, b, c and d. The integers represented by the letters may change from question to question, but the operations to be done remain the same.

K U A R K Y A Y I N L A R I

K U A R K P U B L I C A T I O N S

16.

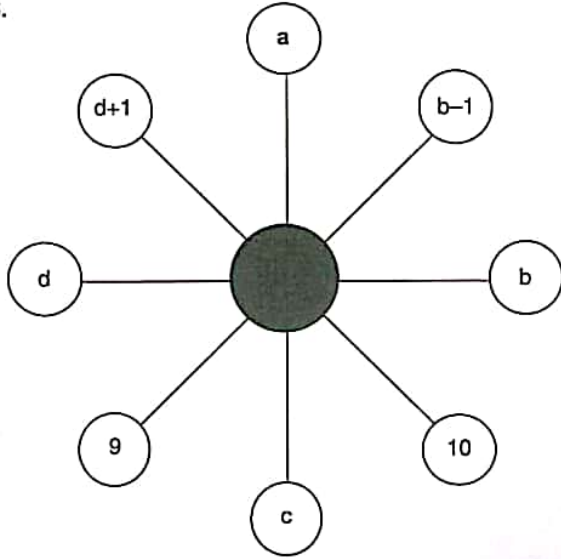

$$\Rightarrow a = ?$$

- A) 2 B) 3 C) 6 D) 7 E) 8

17.

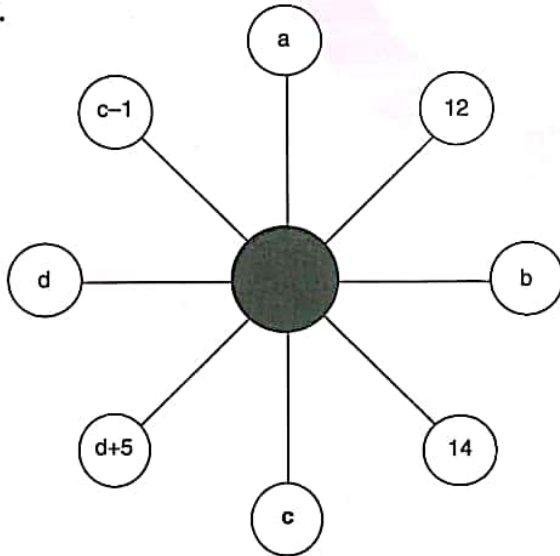

$$\Rightarrow c = ?$$

- A) 3 B) 4 C) 6 D) 7 E) 8

18.

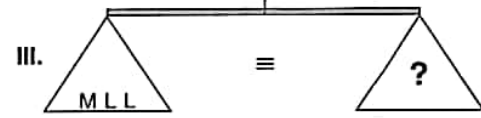
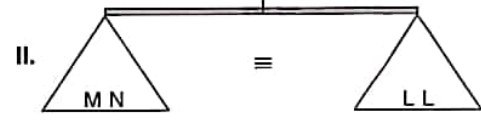
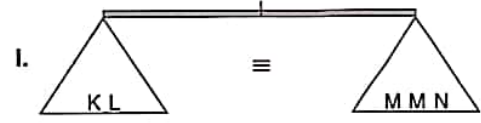

Yukarıdaki terazilerin üçü de dengededir. Buna göre, III. terazideki soru işaretini aşağıdakilerden hangisi göstermektedir?

All three scales above are in balance. Accordingly, which of the following does the question mark stand for in the third scale?

- A) K B) MN C) MM
D) MMN E) NNK

YÖS

8

19.

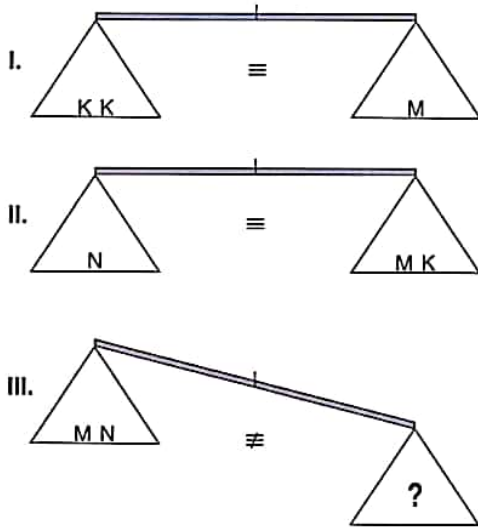

Yukarıdaki terazilerin ilk ikisi dengede olup, üçüncüsü dengede değildir. Buna göre, III. terazideki soru işaretini aşağıdakilerden hangisi göstermektedir?

First two scales above are in balance, the third scale is not in balance. Accordingly, which of the following does the question mark stand for in the third scale?

- A) MM B) KKM C) NK
D) NKK E) MMM

20.

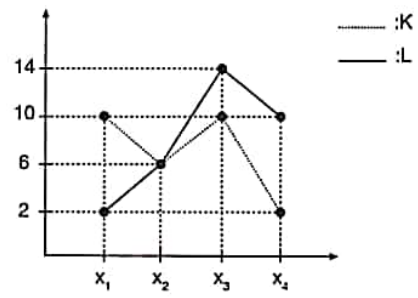

$$\Rightarrow x_1 K - x_2 L - x_3 L + x_4 K = ?$$

Yukarıdaki çizgi grafikte verilen bilgilere göre,

$x_1 K - x_2 L - x_3 L + x_4 K$ kaçtır?

According to the information in the line chart above, what is the value of $x_1 K - x_2 L - x_3 L + x_4 K$?

- A) -8 B) -6 C) -4 D) -2 E) -10

21, 22 ve 23. sorularda, verilen her bir şekil matrisindeki soru işaretinin yerine hangi şeklin getirilmesi gerektiğini bulunuz.

In questions 21, 22 and 23, find the figure which should replace the question mark in each given figure matrix.

21.

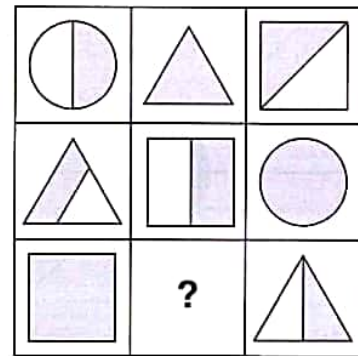

- A)
- B)
- C)
- D)
- E)

YÖS

8

22.

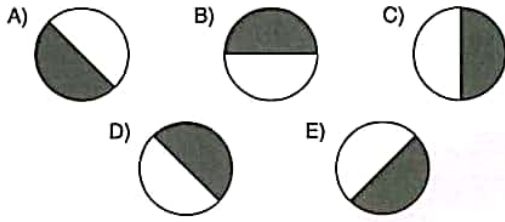
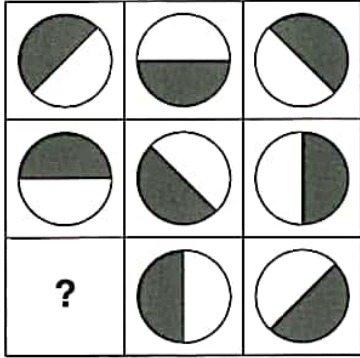

23.

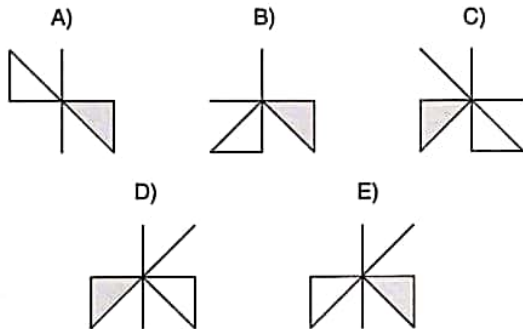
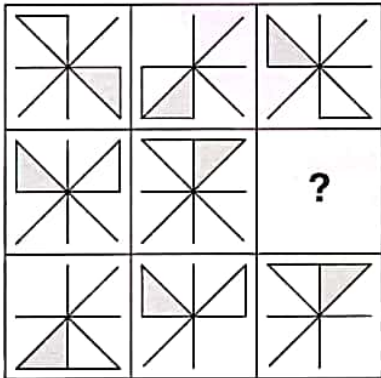

24 ve 25. sorularda, verilen her bir şekil dizisindeki soru işaretinin yerine hangi şeklin getirilmesi gerektiğini bulunuz.

In questions 24 and 25 find the figure which should replace the question mark in each given figure sequence.

24.

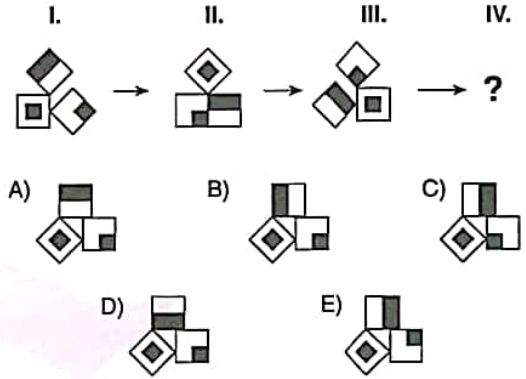

25.

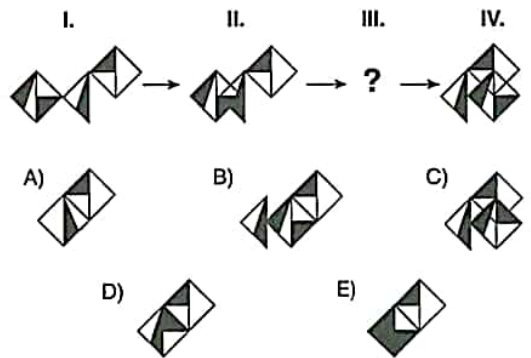

K U A R K Y A Y I N L A R I

K U A R K P U B L I C A T I O N S

26, 27 ve 28. sorularda, I. satırda belirlenen ilişkiye göre II. satırı hangi şeklin tamamladığını bulunuz.

In questions 26, 27 and 28, find the figure which completes row II, in accordance with the relation in row I.

26.

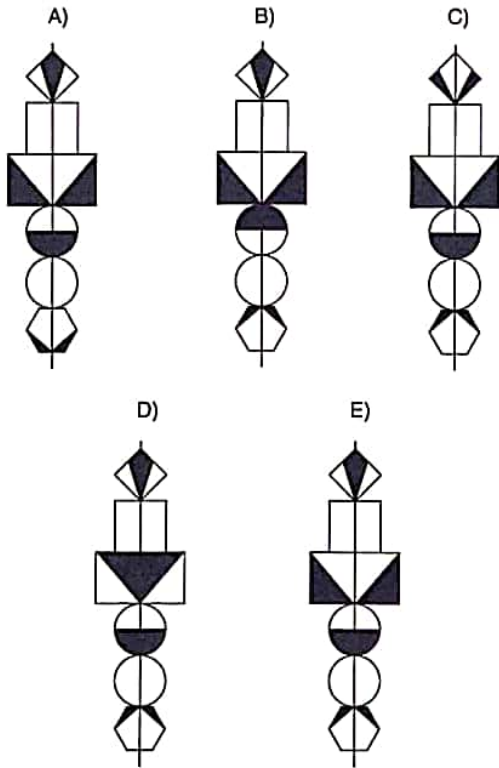
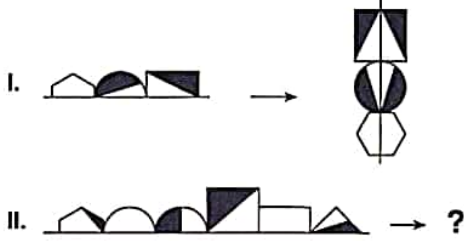

27.

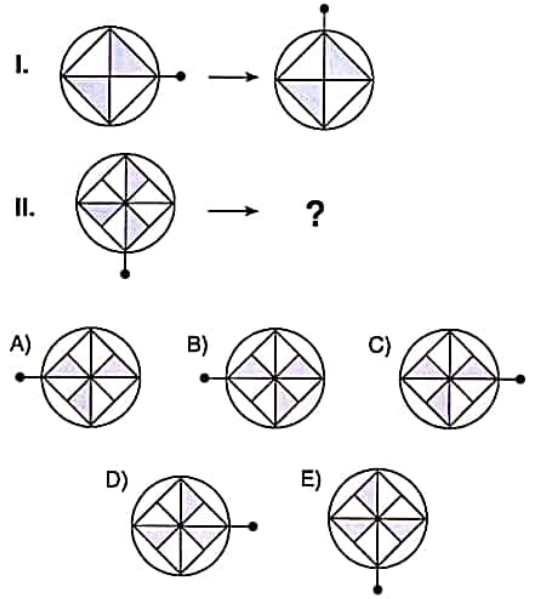

28.

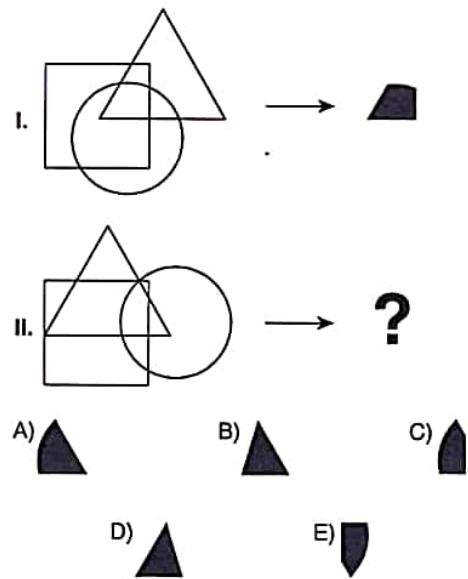

YÖS

8

29. soruyu aşağıdaki örnekte verilen ilişkiye göre cevaplayınız.

Answer question 29, in accordance with the relation established in the example below.

ÖRNEK / EXAMPLE:

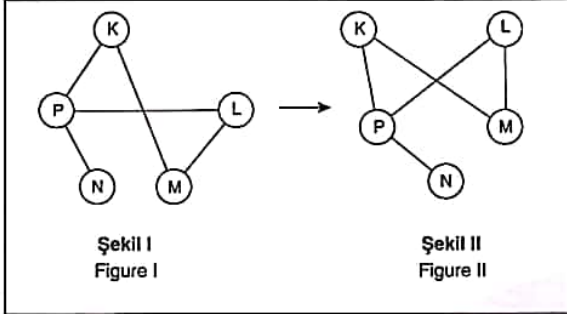

K, L, M, N ve P harfleri I. şekildeki gibi birbirine bağlanmıştır. I. şekildeki bağlantı sayıları ve birbirine bağlanan harfler değişmemek koşuluyla II. şekil elde edilmiştir.

The letters K, L, M, N and P are linked as in figure I. figure II. has been constructed so as not to change the number of links and the letters that are linked to each other in figure I.

29.

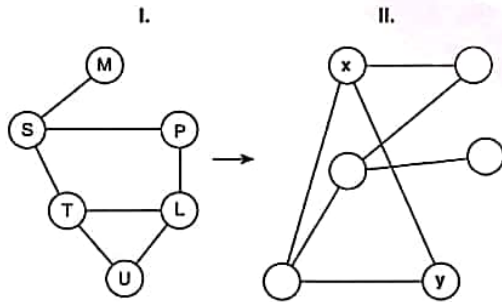

⇒ x ; y = ?

	x	y
A)	S	P
B)	L	U
C)	L	P
D)	T	U
E)	T	L

30. Aşağıdaki şekillerden hangisi diğerlerinden farklıdır?

Which of the following figures is different than the others?

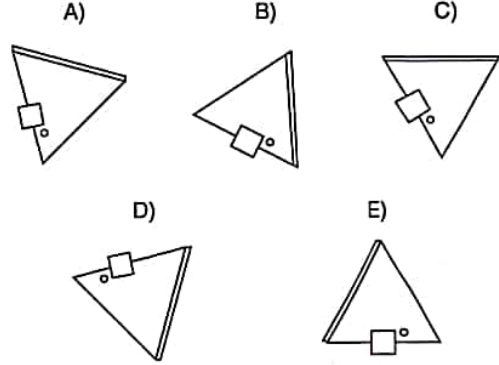

31. soruda, soru işaretinin yerine getirilmesi gereken şekli bulunuz.

In question 31, find the figure to replace the question mark.

31.

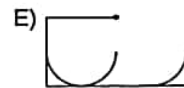
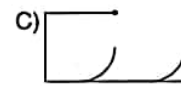
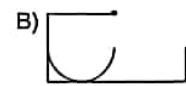
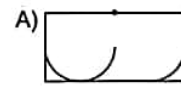
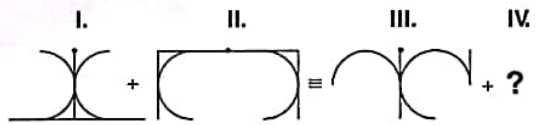

32. soruyu aşağıdaki örnekte verilen ilişkiye göre cevaplayınız.

Answer question 32, in accordance with the relation established in the example below.

ÖRNEK / EXAMPLE:

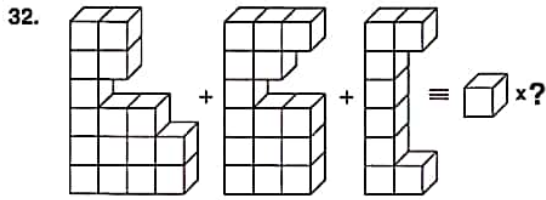
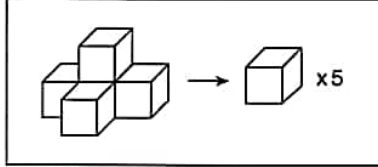

- A) 37 B) 38 C) 39 D) 40 E) 41

33.

I.

II.

III.

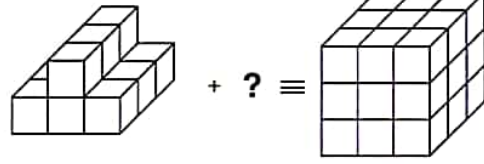

Yukarıdaki birinci satırdaki cisim aşağıdakilerden hangisiyle tamamlanırsa üçüncü satırdaki cisim elde edilir?

The object in the third line is formed when the one in the first line is completed with which of the following?

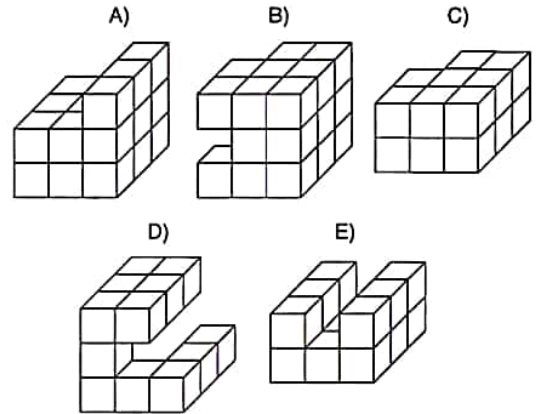

YÖS

8

34.

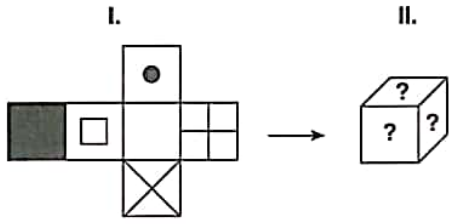

Aşağıdakilerden hangisi I. şekildeki küpün kapalı halidir?

Which of the following corresponds to the folded form of the cube in figure I above?

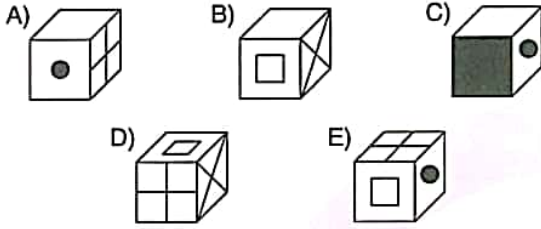

35.

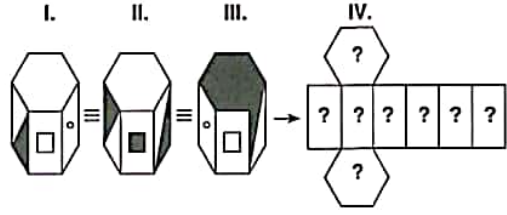

Yukarıdaki şekiller aynı nesneyi göstermektedir. Buna göre bu nesnenin açılmış hali aşağıdakilerden hangisidir?

The figures above represent the same object. Accordingly, which of the following represent the unfolded form of this object?

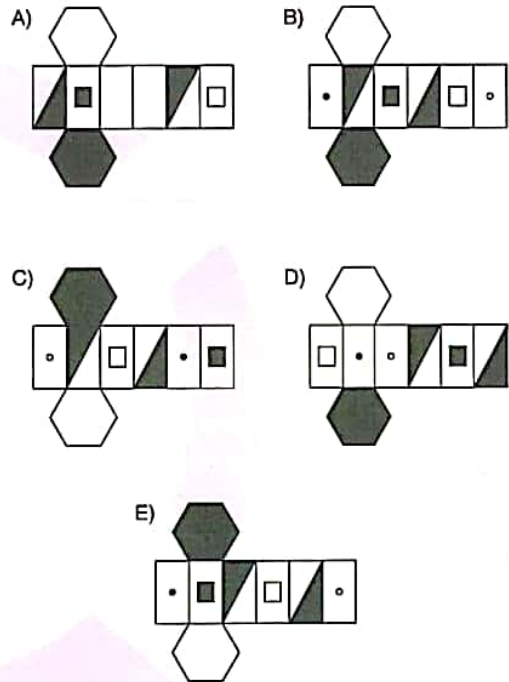

K U A R K Y A Y I N L A R I

K U A R K P U B L I C A T I O N S

YÖS

8

36. $a, b, c \in \mathbb{Z}^+$
 $a - b = 10$
 $a - c = 9$
 $\Rightarrow \min(a + b + c) = ?$
- A) 12 B) 14 C) 15 D) 17 E) 18

37. $(46)_x = (53)_y$
 $\Rightarrow \min(x + y) = ?$
- A) 6 B) 9 C) 12 D) 15 E) 24

38. $(2 - 1\frac{2}{3}) : (1\frac{1}{3} - 1) = ?$
- A) $-\frac{1}{3}$ B) -1 C) 1 D) $\frac{1}{3}$ E) $\frac{2}{3}$

39. $\frac{(3,7)^2 - (2,3)^2}{14} = ?$

- A) $\frac{1}{7}$ B) $\frac{3}{14}$ C) $\frac{3}{5}$ D) $\frac{2}{5}$ E) $\frac{1}{2}$

40.



Şekildeki grafik dünyanın zirai işgücünün 1968 yılındaki dağılımını gösteriyor. Şekilde verilen ülkelerden hangisi yaklaşık olarak dağılımın 1/4'üne sahiptir?

The circle graph above shows the distribution of world's agricultural labor force in the year 1968. Which of these countries had approximately 1/4 of the world's agricultural labor force?

- A) Arjantin / Argentine
 B) Brezilya / Brasil
 C) Hindistan / India
 D) Fas / Morocco
 E) Dünyanın geri kalanı / Rest of the world

K U A R K Y A Y I N L A R I

K U A R K P U B L I C A T I O N S

YÖS

8

41. $a^x = 3,$
 $a^y = 2 \Rightarrow a^{2x-y} = ?$

- A) 1 B) $\frac{2}{3}$ C) $\frac{3}{2}$ D) $\frac{4}{3}$ E) $\frac{9}{2}$

44. $\left. \begin{array}{l} \frac{a}{2} = \frac{b}{4} = \frac{c}{8} \\ \frac{c}{b} + a = 12 \end{array} \right\} \Rightarrow \frac{b}{a} + c = ?$

- A) 10 B) 12 C) 22 D) 42 E) 54

42. $[\sqrt{5-2\sqrt{6}} + \sqrt{2}] \cdot \sqrt{3} = ?$

- A) 1 B) $\sqrt{2}$ C) $\sqrt{3}$ D) 2 E) 3

45. $2 \cdot (x-2) + 3x = 3(x-1) + 9 \Rightarrow x = ?$

- A) 1 B) 2 C) 3 D) 4 E) 5

43. $\frac{\sqrt{6} + \sqrt{3}}{\sqrt{6} + \sqrt{3} - 2 - \sqrt{2}} - \sqrt{6} = ?$

- A) 1 B) $\sqrt{2}$ C) $\sqrt{3}$ D) 3 E) $\sqrt{6}$

46. $x < y < 0 < z$
 $\Rightarrow |x-y| - |y-z| + |x-z| = ?$

- A) $2x - 2y$ B) $x - y + z$ C) $2y - 2x$
D) $2z - 2x$ E) $2y - 2z$

K U A R K Y A Y I N L A R I

K U A R K P U B L I C A T I O N S

YÖS

8

47. $f(x) = \frac{2 \cdot f(x) + 3x}{5} \Rightarrow f^{-1}(5) = ?$

- A) -5 B) $-\frac{1}{5}$ C) 0 D) $\frac{1}{5}$ E) 5

48. $f[f^{-1}(4)] + f[f(x)] = 3x + 4 \Rightarrow (f \circ f)(4) = ?$

- A) 2 B) 4 C) 8 D) 12 E) 16

49. $x \blacktriangle y = x^3 - 3x^2y + 3xy^2 - y^3$

$x \bullet y = x^3 + 3x^2y + 3xy^2 + y^3$

$\Rightarrow (2001 \blacktriangle 2000) \bullet (2000 \blacktriangle 2001) = ?$

- A) -8 B) -4 C) 0 D) 4 E) 8

50. $P(x) = 4x^7 - 2x^4 + 3x^2 + x + 1$

$\Rightarrow d[P(2x^2) + P(-x)] = ?$

- A) -7 B) 0 C) 7 D) 10 E) 14

51. $\frac{x^2 - 4}{x^4} < 0 \Rightarrow \text{ÇK(SS)} = ?$

A) $(-\infty, -2) \cup (0, 2)$

B) $\{-2, 2\}$

C) $\{0\}$

D) $(-2, 2) \setminus \{0\}$

E) $[-2, 2]$

52. $x^2 - 4x = 21 \Rightarrow \text{ÇK(SS)} = ?$

A) $\{-3, 7\}$

B) $\{3, 7\}$

C) \emptyset

D) $\{-7, 3\}$

E) $\{-7, 7\}$

K
U
A
R
K
Y
A
Y
I
N
L
A
R
IK
U
A
R
K
P
U
B
L
I
C
A
T
I
O
N
S

YÖS

8

53. $f(x) = \begin{cases} x^2, & x < 0 \\ x-1, & x \geq 0 \end{cases} \Rightarrow \text{Grafik / Graph} = ?$

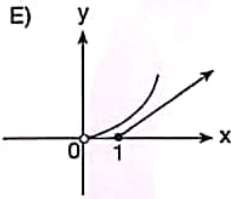
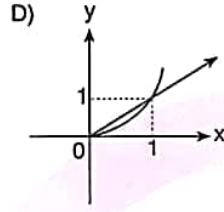
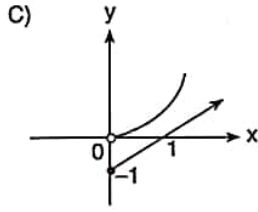
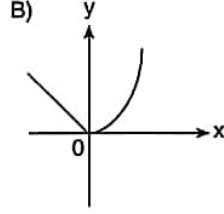
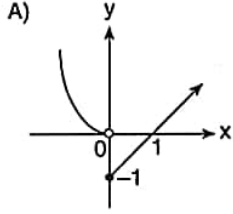

54. $\log_3 2 = x \Rightarrow \log_3 \frac{5}{2} + \log_3 \frac{7}{5} + \log_3 \frac{8}{7} = ?$

- A) $-x$ B) $\frac{x}{2}$ C) x D) $2x$ E) $3x$

55. $i^2 = -1 \Rightarrow i^{4n} + i^{4n-1} - i^{12n} = ?$

- A) $-i$ B) -1 C) 1 D) i E) 2

56. $\frac{\sin 305^\circ}{\cos 35^\circ} + \frac{\tan 50^\circ}{\cot 40^\circ} = ?$

- A) $-\frac{1}{2}$ B) -1 C) 0 D) 1 E) 2

57. $f(x) = x + \frac{3}{x}$,

$f(a) + f\left(\frac{1}{a}\right) = 8 \Rightarrow f(3a) = ?$

- A) 2 B) 3 C) 4 D) 9 E) 16

K U A R K Y A Y I N L A R I

K U A R K P U B L I C A T I O N S

YÖS

8

58. $\lim_{x \rightarrow \infty} (\sqrt{x^2 - 6x + 1} - \sqrt{x^2 - 10x + 4}) = ?$

- A) 1 B) 2 C) 3 D) 4 E) 5

59. $\lim_{x \rightarrow 2} \frac{\sin(x-2)}{x^2-4} = ?$

- A) $\frac{1}{4}$ B) $\frac{1}{2}$ C) 1 D) 2 E) 3

60. $f(x) = 3x \cdot \ln x^2 \Rightarrow f'''(1) = ?$

- A) 6 B) 3 C) -3 D) -6 E) -9

61. $4x^2 - xy - y^3 = 6 \Rightarrow \left. \frac{dy}{dx} \right|_{(x=1, y=-1)} = ?$

- A) $\frac{9}{4}$ B) $\frac{3}{2}$ C) $-\frac{7}{4}$ D) -2 E) $-\frac{9}{4}$

62. $\int \frac{\sin(e^{-x})}{e^x} dx = ?$

- A) $-\sin(e^{-x}) + C$ B) $-\cos(e^{-x}) + C$
 C) $\cos(e^{-x}) + C$ D) $\sin(e^x) + C$
 E) $\cos(e^x) + C$

63.

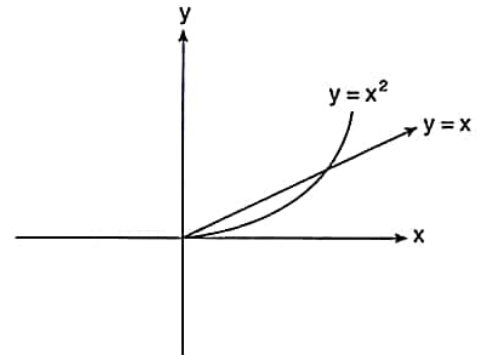

Taralı Alan / Shaded Area = ? cm²

- A) $\frac{1}{6}$ B) $\frac{1}{4}$ C) $\frac{1}{2}$ D) 1 E) 4

K
U
A
R
K
Y
A
Y
I
N
L
A
R
IK
U
A
R
K
P
U
B
L
I
C
A
T
I
O
N
S

$$64. f(x) = \begin{cases} x^2 - mx + 2 & x > 1 \\ 3 & x = 1 \\ 3nx + 6 & x < 1 \end{cases}$$

$f(x)$ \mathbb{R} de süreklilise $m - n = ?$
If $f(x)$ is continuous in \mathbb{R} , $m - n = ?$

- A) 1 B) 2 C) 3 D) 4 E) 5

66.

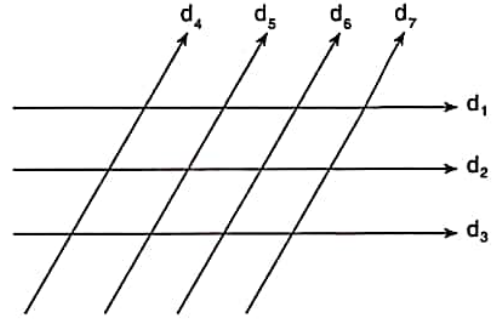

$$d_1 \parallel d_2 \parallel d_3, \quad d_4 \parallel d_5 \parallel d_6 \parallel d_7$$

Şekilde kaç paralelkenar vardır?

How many different parallelograms exist in the figure?

- A) 12 B) 14 C) 16 D) 18 E) 20

K U A R K Y A Y I N L A R I

K U A R K P U B L I C A T I O N S

$$65. a^2 = b^2 + c^2 + bc \\ \Rightarrow m(\hat{A}) = ?$$

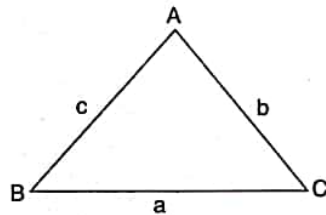

- A) 30° B) 45° C) 60° D) 90° E) 120°

$$67. A = \begin{bmatrix} 3 & 4 \\ 4 & 5 \end{bmatrix} \Rightarrow A^{-1} = ?$$

- A) $\begin{bmatrix} 3 & 4 \\ 4 & 5 \end{bmatrix}$ B) $\begin{bmatrix} -5 & 4 \\ 4 & -3 \end{bmatrix}$ C) $\begin{bmatrix} 3 & -4 \\ -4 & 5 \end{bmatrix}$
D) $\begin{bmatrix} -3 & 4 \\ 4 & -5 \end{bmatrix}$ E) $\begin{bmatrix} -5 & -4 \\ -4 & -3 \end{bmatrix}$

YÖS

8

68. $(ab) \in \mathbb{N}$
 $\left. \begin{array}{l} ab \equiv 2 \pmod{3} \\ ab \equiv 2 \pmod{5} \end{array} \right\} \Rightarrow \max(ab) + \min(ab) = ?$
 A) 92 B) 109 C) 124 D) 154 E) 169

69. $x^2 - (x_1 + 3) \cdot x + 5x_2 = 0,$
 $\text{ÇK(SS)} = \{x_1, x_2\}$
 $\Rightarrow x_1 - x_2 = ?$
 A) -4 B) -2 C) 0 D) 2 E) 4

- 70 $\sin 17^\circ \cdot \cos 13^\circ + \cos 17^\circ \cdot \sin 13^\circ = ?$
 A) $\frac{\sqrt{3}}{2}$ B) $\frac{\sqrt{3}}{3}$ C) $\frac{\sqrt{2}}{2}$ D) 1 E) $\frac{1}{2}$

71.

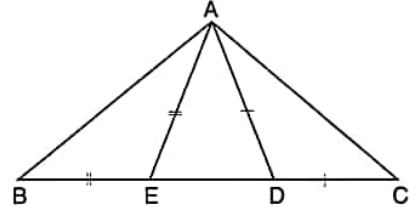

$$|AE| = |BE|, |AD| = |DC|,$$

$$m(\widehat{AED}) = 50^\circ, m(\widehat{ADE}) = 60^\circ \Rightarrow m(\widehat{BAC}) = ?$$

- A) 100° B) 105° C) 110° D) 120° E) 125°

72.

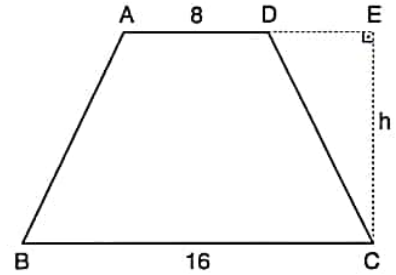

ABCD bir yamuktur. / ABCD is a trapezoid.

$$|AD| = 8 \text{ cm}, |BC| = 16 \text{ cm}, A(ABCD) = 144 \text{ cm}^2$$

$$\Rightarrow |EC| = h = ? \text{ cm}$$

- A) 10 B) 12 C) 13 D) 14 E) 16

YÖS

8

73.

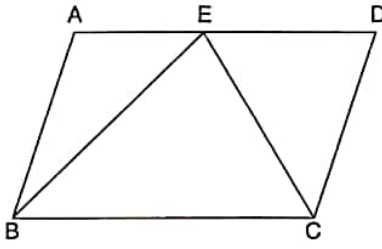

ABCD bir paralelkenardır. / ABCD is a parallelogram.

$A(ABCD) = 48 \text{ cm}^2$

\Rightarrow Taralı Alan / Shaded Area = ? cm^2

A) 12 B) 18 C) 24 D) 28 E) 23

75. $d_1 : 2x - ay + 7 = 0$

$d_2 : -3x + 6y + 8 = 0$

$d_1 \perp d_2 \Rightarrow a = ?$

A) -2 B) -1 C) $-\frac{1}{2}$ D) 1 E) 2

K U A R K Y A Y I N L A R I

76.

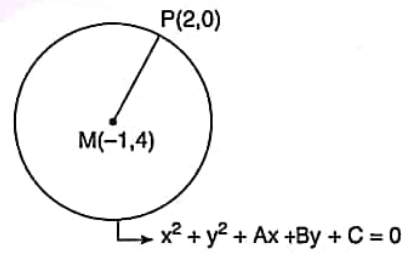

74. $m(\widehat{AKC}) = 30^\circ$,
 $m(\widehat{AC}) = 20^\circ$
 $\Rightarrow m(\widehat{BD}) = ?$

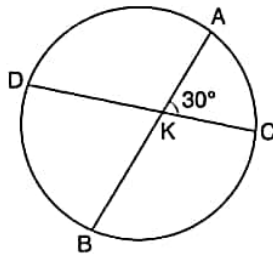

A) 20° B) 30° C) 40° D) 50° E) 60°

K U A R K P U B L I C A T I O N S

$M(-1, 4)$ noktası şekildeki çemberin merkezidir. $P(2, 0)$ çember üzerinde bir nokta ise $A + B + C$ kaçtır?

$M(-1, 4)$ is the center of the circle in the figure. If $P(2, 0)$ is a point that located on the circle, what is the value of $A + B + C$?

A) -14 B) -12 C) 2 D) 12 E) 14

YÖS

8

77.

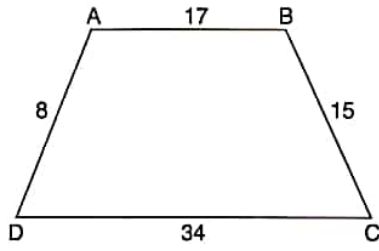

ABCD bir yamuktur. / ABCD is a trapezoid.

$|AB| = 17$ cm,

$|AD| = 8$ cm,

$|BC| = 15$ cm,

$|DC| = 34$ cm

$\Rightarrow A(ABCD) = ? \text{ cm}^2$

- A) 60 B) 80 C) 100 D) 120 E) 180

78.

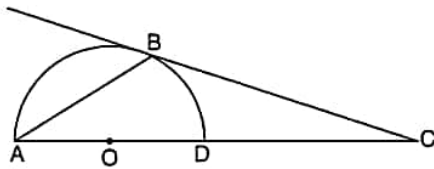

O merkezi yarım çemberde,

In the semi-circle with center of O,

$m(\widehat{BAC}) = \alpha$

$m(\widehat{BCA}) = 40^\circ$

$\Rightarrow \alpha = ?$

- A) 20° B) 25° C) 30° D) 40° E) 50°

79.

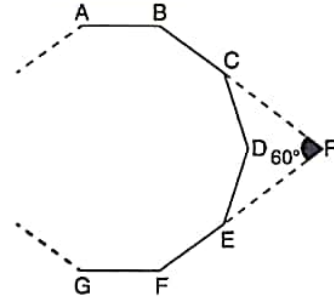

Yukarıdaki düzgün çokgende $m(\widehat{BTE}) = 60^\circ$ olduğuna göre; çokgen kaç kenarlıdır?

If $m(\widehat{BTE}) = 60^\circ$ in the polygon above, how many sides does the polygon have?

- A) 8 B) 9 C) 10 D) 12 E) 14

K U A R K Y A Y I N L A R I

K U A R K P U B L I C A T I O N S

80.

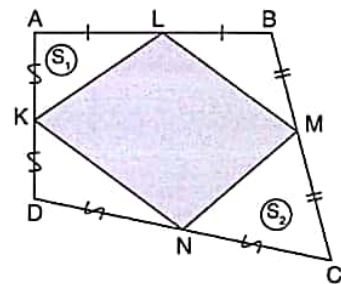

$S_1 + S_2 = 32 br^2 (u^2)$

$\Rightarrow A(KLMN) = ? br^2 (u^2)$

- A) 16 B) 32 C) 48 D) 64 E) 82

1. $[(2005 - 1905) - 500]^0 \cdot (-1) - (-1) = ?$

- A) -500 B) -499 C) -2 D) 0 E) 2

3. $\frac{(y+1)!}{(x-1)!} = 24 \Rightarrow \min(x+y) = ?$

- A) 4 B) 5 C) 6 D) 7 E) 8

K
U
A
R
K
Y
A
Y
I
N
L
A
R
I

4. $\frac{9x^2 + y^2 - 6xy - 1}{3x - y + 1} + 1 = ?$

- A) -1 B) 0 C) 1
-
- D)
- $3x + y$
- E)
- $3x - y$

K
U
A
R
K
P
U
B
L
I
C
A
T
I
O
N
S

2. 4 kişilik domates çorbası yapmak için 5 domates kullanılmıştır. Bu durumda 20 kişilik domates çorbası yapmak için kaç domates kullanılır?

A recipe for tomato soup for 4 people requires 5 tomatoes. At this rate how many tomatoes are required to make tomato soup for 20 people?

- A) 16 B) 20 C) 25 D) 28 E) 32

5. $\left. \begin{array}{l} 4^x = 9^{-1} \\ 8^y = 27 \end{array} \right\} \Rightarrow \frac{2x-y}{2x+y} = ?$

- A) -2 B) -1 C) 1 D) 2 E) 3

YÖS

9

6. $\sqrt{1000 \cdot 1001 - 1000 \cdot 999} = ?$

- A) 10 B) $5\sqrt{2}$ C) 20
D) $20\sqrt{5}$ E) $15\sqrt{2}$

8. $x \cdot y = 8, z \cdot x = 6,$
 $y - z = 3 \Rightarrow 3x = ?$

- A) 1 B) 2 C) 3 D) 4 E) 5

K
U
A
R
K
Y
A
Y
I
N
L
A
R
IK
U
A
R
K
P
U
B
L
I
C
A
T
I
O
N
S

7. $\frac{a}{b} = \frac{2x}{3y} = \frac{m}{n} = \frac{1}{2} \Rightarrow \frac{3a - 6x + 3m}{3b - 9y + 3n} = ?$

- A) $-\frac{1}{2}$ B) -1 C) $\frac{1}{2}$ D) 1 E) $\frac{3}{2}$

9. $A = \{1, 2, 3, 4\},$
 $f: A \rightarrow A, g: A \rightarrow A$

$$f = \begin{pmatrix} 1 & 2 & 3 & 4 \\ 4 & 3 & 2 & 1 \end{pmatrix}, g = \begin{pmatrix} 1 & 2 & 3 & 4 \\ 2 & 3 & 1 & 4 \end{pmatrix} \Rightarrow (f \circ g^{-1}) = ?$$

- A) $\begin{pmatrix} 1 & 2 & 3 & 4 \\ 2 & 4 & 3 & 1 \end{pmatrix}$ B) $\begin{pmatrix} 1 & 2 & 3 & 4 \\ 4 & 2 & 3 & 1 \end{pmatrix}$
C) $\begin{pmatrix} 1 & 2 & 3 & 4 \\ 2 & 4 & 1 & 3 \end{pmatrix}$ D) $\begin{pmatrix} 1 & 2 & 3 & 4 \\ 3 & 2 & 4 & 1 \end{pmatrix}$
E) $\begin{pmatrix} 1 & 2 & 3 & 4 \\ 1 & 2 & 4 & 3 \end{pmatrix}$

10.

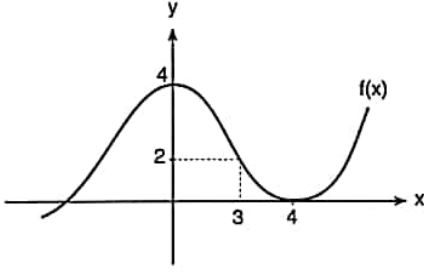

$$\Rightarrow f^{-1}(4) + f(4) + f(3) = ?$$

- A) 1 B) 2 C) 3 D) 4 E) 5

11. $x, y \in \mathbb{Z}$,

$$\left. \begin{array}{l} -3 < x \leq 8 \\ -7 \leq y < 12 \end{array} \right\} \Rightarrow \max(2x - y) = ?$$

- A) 18 B) 21 C) 23 D) 26 E) 30

12. $|6 - 5x| + |10x - 12| = 12 \Rightarrow \prod x = ?$

- A) 1 B) $\frac{2}{5}$ C) $\frac{4}{5}$ D) 2 E) $\frac{5}{2}$

13. $x \in \mathbb{Z}$,

$$193^x \equiv 2 \pmod{5},$$

$$10 < x < 20 \Rightarrow \sum x = ?$$

- A) 11 B) 15 C) 19 D) 34 E) 45

14. $\frac{7x+5}{2x^2+3x+1} = \frac{A}{x+1} + \frac{B}{2x+1} \Rightarrow A+B = ?$

- A) 3 B) 5 C) 6 D) 9 E) 11

15. $x^2 - |2x| - 8 = 0$, $\text{ÇK(SS)} = \{x_1, x_2\}$
 $\Rightarrow \text{ÇK(SS)} = ?$

- A) $\{-2, 2\}$ B) $\{-4, 4\}$ C) $\{-4, -2\}$
D) $\{2, 4\}$ E) $\{-4, -2, 2, 4\}$

YÖS

9

16. $\begin{cases} 3x - 6 \leq 0 \\ x^2 - 9 \leq 0 \end{cases} \Rightarrow \text{ÇK(SS)} = ?$

- A) $[-2, 3]$
 B) $[-3, 2]$
 C) $(-3, 3)$
 D) $[-3, 3]$
 E) $[2, \infty]$

18. $\frac{\sin x - 2\cos x}{2\sin x - \cos x} = \frac{3}{5} \Rightarrow \cot x = ?$

- A) $-\frac{1}{7}$ B) $-\frac{2}{5}$ C) $-\frac{1}{5}$ D) $\frac{3}{5}$ E) $\frac{3}{7}$

K
U
A
R
K
Y
A
Y
I
N
L
A
R
I

19. $\sin 10^\circ = x \Rightarrow \frac{\sin 170^\circ + \sin 80^\circ}{\cos(-10^\circ)} = ?$

- A) $x + \sqrt{1-x^2}$ B) $-x + \sqrt{1-x^2}$
 C) $\frac{\sqrt{1-x^2}}{x}$ D) $\frac{x + \sqrt{1-x^2}}{\sqrt{1-x^2}}$
 E) $\frac{x + \sqrt{1-x^2}}{x\sqrt{1-x^2}}$

K
U
A
R
K
P
U
B
L
I
C
A
T
I
O
N
S

17.

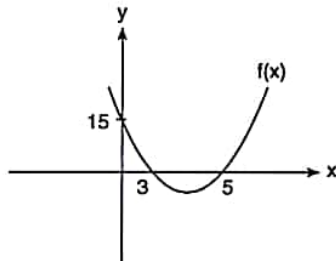

$\Rightarrow \frac{f(10)}{f(7)} = ?$

- A) $\frac{313}{9}$ B) $\frac{33}{17}$ C) $\frac{35}{8}$ D) $\frac{39}{4}$ E) $\frac{40}{3}$

20. $(2x - y)^6 = \dots + A \cdot x^5y + \dots \Rightarrow A = ?$

- A) -211 B) -192 C) 48 D) 192 E) 211

21. $5^{\log_5 x} + 6^{\log_6 2} = \log_3 81 \Rightarrow x = ?$

- A) 2 B) -4 C) -1 D) 1 E) 3

24. $\lim_{x \rightarrow \infty} \left(\frac{2x+1}{x-1} \right)^x = ?$

- A) e B) e² C) e³ D) 0 E) ∞

K U A R K Y A Y I N L A R I

22. $i = \sqrt{-1}$,
 $x^2 + 9 = 0 \Rightarrow \text{ÇK(SS)} = ?$

- A) $\{-3, 3\}$ B) $\{-i, i\}$ C) $\{-2i, 2i\}$
D) $\{-3i, 3i\}$ E) $\{-\sqrt{3}, \sqrt{3}\}$

25. $f(x) = \tan(e^x) \Rightarrow f(\ln(\pi)) = ?$

- A) $-\pi$ B) $-\frac{\pi}{2}$ C) 1 D) e^π E) π

K U A R K P U B L I C A T I O N S

23. $f(x) = x^2 - 2x + 3$, $g(x) = 2x - 1$

$\Rightarrow \lim_{x \rightarrow 2} \left(\frac{f(x)}{g(x)} + \frac{x}{2} \right) = ?$

- A) 1 B) 2 C) 3 D) 4 E) 5

26. $y = \sin 2x + e^{2x} + x^9 \Rightarrow \frac{d^{10}y}{dx^{10}} = ?$

- A) $\sin 2x + e^{2x}$
B) $2^{10} \sin 2x + e^{2x} + 9!$
C) $2^{10}(e^{2x} - \sin 2x)$
D) $2^{10}(e^{2x} + \sin 2x + 9!)$
E) $2^{10}(\cos 2x - e^{2x})$

YÖS

9

27. $\int \frac{\arctan x}{2+2x^2} dx = ?$

- A) $\arctan x + C$ B) $\frac{\tan x}{2} + C$ C) $\frac{\tan x}{4} + C$
 D) $\frac{\arctan x}{2} + C$ E) $\frac{\arctan^2 x}{4} + C$

28.

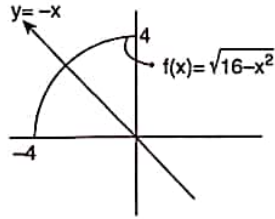

$f: [-4, 0] \Rightarrow \mathbb{R}$

$\Rightarrow \int_{-2\sqrt{2}}^0 (\sqrt{16-x^2} + x) dx = ?$

- A) 2π B) $\frac{3\pi}{2}$ C) π D) $\frac{\pi}{2}$ E) $\frac{\pi}{4}$

29. $A = \begin{bmatrix} 4 & 3 \\ 9 & 7 \end{bmatrix}$, $I_{2 \times 2} = \begin{bmatrix} 1 & 0 \\ 0 & 1 \end{bmatrix}$, $A \cdot B = I_{2 \times 2} \Rightarrow B = ?$

- A) $\begin{bmatrix} 7 & -3 \\ -9 & 4 \end{bmatrix}$ B) $\begin{bmatrix} 4 & 3 \\ 9 & 7 \end{bmatrix}$ C) $\begin{bmatrix} -4 & 3 \\ 3 & -7 \end{bmatrix}$
 D) $\begin{bmatrix} -3 & 7 \\ 4 & -9 \end{bmatrix}$ E) $\begin{bmatrix} -7 & 3 \\ 9 & -4 \end{bmatrix}$

30.

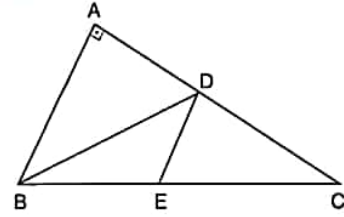

$2 \cdot |BE| = |EC|$, $|AB| = 16 \text{ cm}$, $|DC| = 12 \text{ cm}$

\Rightarrow Taralı Alan / The Shaded Area = ? cm^2

- A) 14 B) 28 C) 32 D) 36 E) 48

31.

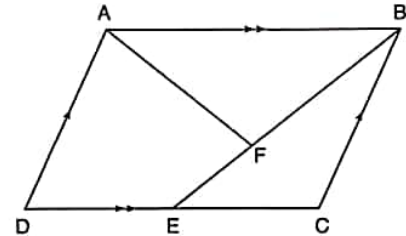

$[AB] \parallel [DC]$, $[AD] \parallel [BC]$, $5 \cdot |EF| = |FB|$, $T_A/S_A = 25 \text{ cm}^2$

$\Rightarrow A(ABCD) = ? \text{ cm}^2$

- A) 50 B) 55 C) 60 D) 70 E) 80

32.

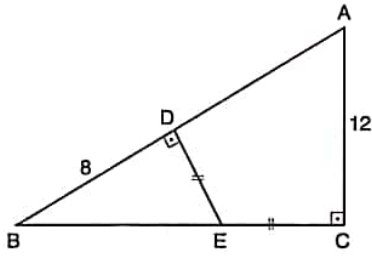

$[AC] \perp [BC]$, $[ED] \perp [AB]$, $|AC| = 12 \text{ cm}$, $|ID| = 8 \text{ cm}$
 $\Rightarrow |DE| = ? \text{ cm}$

- A) 4 B) 5 C) 6 D) 7 E) 8

34.

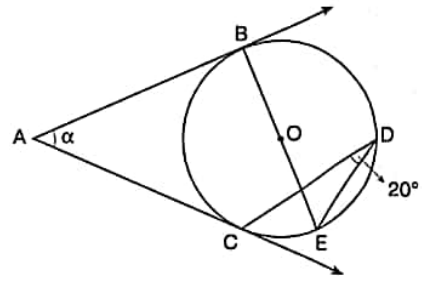

O noktası şekildeki çemberin merkezidir.
 The point O is center of the circle in the figure.

$\Rightarrow \alpha = ?$

- A) 20° B) 30° C) 40° D) 50° E) 60°

33.

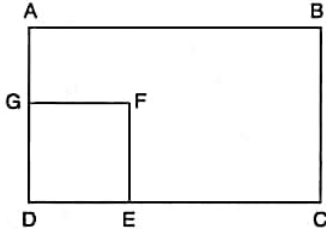

ABCD bir dikdörtgen, DEFG bir karedir.

ABCD is a rectangle, DEFG is a square.

$|EC| = 2 \cdot |DE|$, $|AG| = |GD|$, $T_A/SA = 50 \text{ cm}^2$

$\Rightarrow A(\text{DEFG}) = ? \text{ cm}^2$

- A) 10 B) 20 C) 25 D) 30 E) 35

35. $\vec{A} = (-4, 3)$ $\vec{B} = (-2, -1)$ $\Rightarrow \vec{A} \cdot \vec{B} = ?$

- A) 1 B) 2 C) 3 D) 4 E) 5

36, 37, 38 ve 39. sorularda I. gruptaki her bir harf, rakam veya şekil, II. gruptaki farklı birer harf, rakam veya şekil ile gösterilmiştir. Buna göre, soru işaretleriyle belirtilen harfleri, rakamları veya şekilleri bulunuz. In questions 36, 37, 38 and 39 each letter, numeral or figure in group I stand for a different letter, numeral or figure in group II. Accordingly, find the letters, numerals or figures which the questions mark stands for.

36.

I.	II.
K L M	4 5 6
M N R	6 5 7
T K Y	7 5 9
R N T	7 9 1
T N K	9 2 4

⇒ MNR = ?

- A) 924 B) 791 C) 759 D) 657 E) 456

37.

I.	II.
A R E N	9 4 5 2
T İ M U	1 7 2 8
K A R E	2 5 2 9
K U M E	6 3 5 4
E M E K	9 1 7 2

⇒ KARE = ?

- A) 9452 B) 1728 C) 2529
D) 6354 E) 9172

38.

I.	II.
S İ N E M	7 6 3 5 9
K A F E S	4 3 0 5 7
İ M S E L	9 0 4 5 2
A S K E R	0 2 9 5 1
N F İ E K	6 9 7 5 8

⇒ SİNEM = ?

- A) 76359 B) 43057 C) 90452
D) 02951 E) 69758

39.

I.	II.
9 3 2 0 4	▲ ⊃ □ ✓ →
8 3 2 9 7	+ ⊃ ⊗ × →
7 6 4 6 2	✓ ⊃ ⊗ × □
0 3 4 6 7	→ × ⊗ × □
9 3 4 6 2	✓ ⊃ □ + ⊗

⇒ 23489 = ?

- A) □ ⊃ ⊗ ▲ ✓ B) → □ ⊗ ▲ ✓
C) □ → ▲ ⊗ ✓ D) ✓ × + → □
E) ✓ ⊗ ▲ → □

K U A R K Y A Y I N L A R I

K U A R K P U B L İ C A T İ O N S

40. I. $3 \square 7 = 27$

II. $2 \square 3 = 13$

III. $5 \square 1 = 13$

IV. $4 \square 4 = ?$

Yukarıdaki eşitliklerde \square işaretinin görevi verilmiştir. Buna göre, dördüncü eşitlikteki soru işaretinin yerine aşağıdaki sayılardan hangisi gelmelidir?

In the equations above, the function of \square is given. Accordingly, which of the following numbers does the question mark stand for in the fourth equation?

- A) 17 B) 18 C) 19 D) 20 E) 21

41. I. $a * b = 3a + b$

II. $a \blacktriangle b = 4a - 3b$

III. $(4 * 5) \blacktriangle (4 * 4) = ?$

Yukarıdaki eşitliklerde $*$ ve \blacktriangle işaretlerinin görevleri verilmiştir. Buna göre, üçüncü eşitlikteki soru işaretinin yerine aşağıdaki sayılardan hangisi gelmelidir?

In the equations above, the functions of $*$ and \blacktriangle are given. Accordingly, which of the following numbers does the question mark stand for in the third equation?

- A) 10 B) 20 C) 30 D) 40 E) 50

42. I. $a \circ b = 3 \cdot (b \circ a) - a \cdot b$

II. $3 \circ 4 = ?$

Yukarıdaki birinci eşitlikte \circ işaretinin görevi verilmiştir. Buna göre, ikinci eşitlikteki soru işaretinin yerine aşağıdaki sayılardan hangisi gelmelidir?

In the first equation above, the function of \circ is given. Accordingly, which of the following numbers does the question mark stand for in the second equation?

- A) 6 B) 8 C) 10 D) 12 E) 14

43. I. $x \square y = 2(x \Delta y)$

II. $x \Delta y = x \nabla (y - 2)$

III. $x \nabla y = x + y$

IV. $5 \square 4 = ?$

Yukarıdaki eşitliklerde \square , Δ ve ∇ işaretlerinin görevleri verilmiştir. Buna göre, dördüncü eşitlikteki soru işaretinin yerine aşağıdaki sayılardan hangisi gelmelidir?

In the equations above, the functions of \square , Δ and ∇ are given. Accordingly, which of the following numbers does the question mark stand for in the fourth equation?

- A) 8 B) 10 C) 12 D) 14 E) 16

44, 45 ve 46. sorulardaki verilen işlemlerde her harf sıfırdan ve birbirinden farklı birer rakamı göstermektedir. Buna göre, soru işareti ile belirtilen harf ya da işlemin değerini bulunuz.

In the operations which are given in questions 44, 45 and 46 each letter stands for a different non-zero numeral. Accordingly, find the value of the letter or operation indicated by the questions mark.

$$44. \begin{array}{r} AB \\ + BA \\ \hline 88 \end{array} \Rightarrow \max(A \cdot B) - \min(A \cdot B) = ?$$

- A) 16 B) 15 C) 9 D) 8 E) 7

$$45. \begin{array}{r} KLM \\ - MLK \\ \hline NR7 \end{array} \Rightarrow N = ?$$

- A) 2 B) 3 C) 4 D) 5 E) 6

$$46. \begin{array}{r} 4AB \\ + CBA \\ \hline 721 \end{array} \quad \begin{array}{r} BA \\ - AB \\ \hline 27 \end{array} \Rightarrow ABC = ?$$

- A) 247 B) 286 C) 427 D) 682 E) 472

47, 48 ve 49. soruları aşağıdaki şekle göre cevaplayınız.
Answer questions 47, 48 and 49 in accordance with the figure given below.

Her soru birbirinden bağımsız olarak cevaplanacaktır.
Each question is to be answered independently.

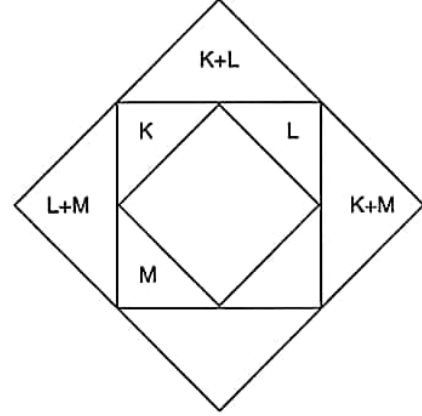

Yukarıdaki şekil K, L ve M harfleriyle gösterilen üç pozitif tamsayıyı içeren bazı işlemlere göre düzenlenmiştir. Harflerin gösterdiği sayılar her soruda farklı olabilir; fakat yapılacak işlemler her soruda aynıdır.

The figure above has been organized according to various operations using three positive integers represented by the letters K, L and M. The integers represented by the letters may change from question to question, but the operations to be done remain the same.

47.

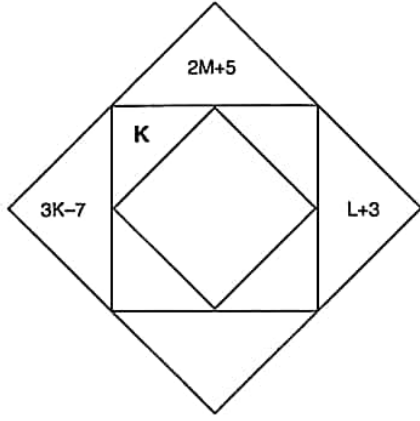

$$\Rightarrow K = ?$$

- A) 1 B) 2 C) 4 D) 6 E) 8

48.

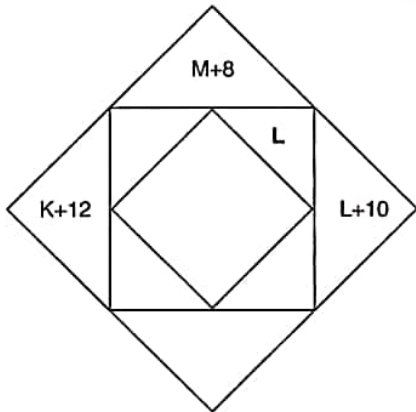

$$\Rightarrow L = ?$$

- A) 8 B) 10 C) 12 D) 14 E) 16

49.

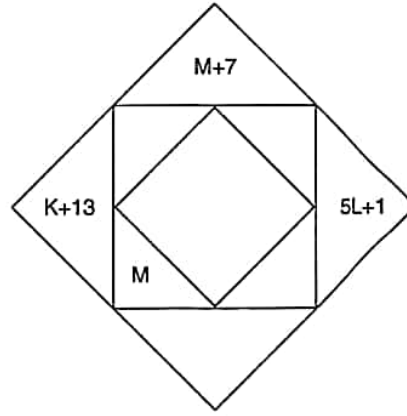

$$\Rightarrow M = ?$$

- A) 24 B) 27 C) 30 D) 33 E) 36

50.

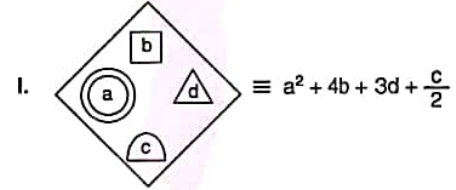

I. ve II. satırlarda belirlenen ilişkiye göre, III. satırı aşağıdaki sayılardan hangisi tamamlar?
Which of the following numbers completes III. in accordance with the relation established in I and II?

- A) 54 B) 52 C) 50 D) 48 E) 46

YÖS

9

51.

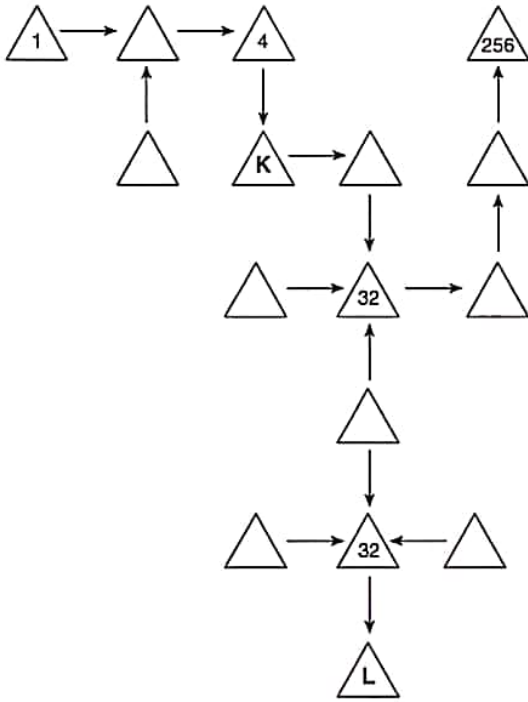

$$\Rightarrow K + L = ?$$

Yukarıdaki sayı-şekil dizisine göre $K + L$ kaçtır?

What is the value of $K + L$, according to the number-figure sequence above?

- A) 70 B) 71 C) 72 D) 73 E) 74

52.

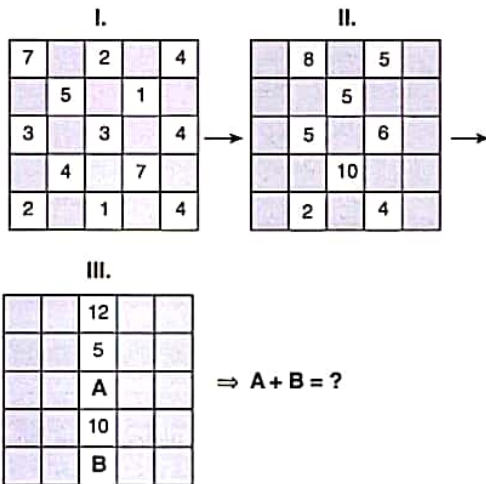

$$\Rightarrow A + B = ?$$

Yukarıdaki sayı-şekil dizisine göre $A + B$ kaçtır?

What is the value of $A + B$, according to the number-figure sequence above?

- A) 9 B) 11 C) 13 D) 15 E) 17

53.

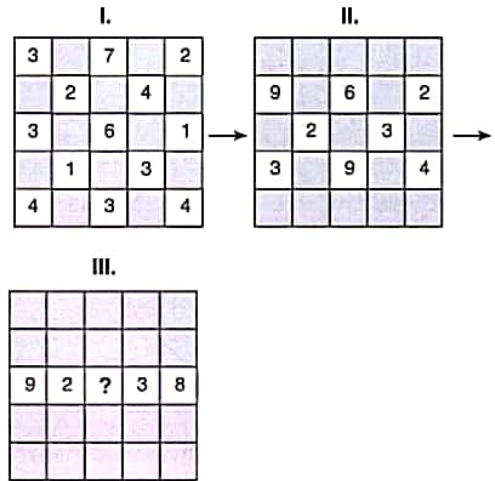

Yukarıdaki sayı-şekil dizisine göre soru işaretinin yerine aşağıdaki sayılardan hangisi gelmelidir?

Which of the following numbers does the question mark stand for, according to the number-figure sequence above?

- A) 6 B) 7 C) 8 D) 9 E) 10

54.

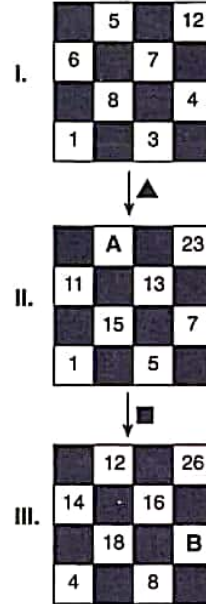

$$\Rightarrow A + B = ?$$

Yukarıdaki sayı-şekil dizisine göre $A + B$ kaçtır?

What is the value of $A + B$, according to the number-figure sequence above?

- A) 19 B) 20 C) 21 D) 22 E) 23

K U A R K Y A Y I N L A R I

K U A R K P U B L I C A T I O N S

55.

+	a	b	c
a		c+7	
b			2a+5
c	3b-1		

$$\Rightarrow c - a = ?$$

Yukarıdaki toplama tablosunda a, b ve c harfleri pozitif birer tam sayının yerine kullanılmıştır. Buna göre, $c - a$ kaçtır?

In the summation table above, the letters a, b and c each stands for a positive integer. Accordingly, what is the value of $c - a$?

- A) 8 B) 7 C) 6 D) 5 E) 4

56.

x	a	b	c
a		18	
b			
c	b^2		144

$$\Rightarrow a = ?$$

Yukarıdaki çarpma tablosunda a, b ve c harfleri pozitif birer tam sayının yerine kullanılmıştır. Buna göre, a kaçtır?

In the multiplication table above, the letters a, b and c each stands for a positive integer. Accordingly, what is the value of a?

- A) 3 B) 6 C) 9 D) 12 E) 15

57.

x	a	b	c
a	196		
b			
c			225

$$\Rightarrow d = ?$$

Yukarıdaki toplama ve çarpma tablolarında a, b ve c harfleri pozitif birer tam sayının yerine kullanılmıştır. Buna göre, d kaçtır?

In the summation and multiplication tables above, the letters a, b and c each stands for a positive integer.

Accordingly, what is the value of d?

- A) 21 B) 20 C) 19 D) 18 E) 17

58.

x	a	b	c
a			100
b	140		
c			

$$\Rightarrow a = ?$$

Yukarıdaki toplama ve çarpma tablolarında a, b ve c harfleri pozitif birer tam sayının yerine kullanılmıştır. Buna göre, a kaçtır?

In the summation and multiplication tables above, the letters a, b and c each stands for a positive integer.

Accordingly, what is the value of a?

- A) 16 B) 17 C) 18 D) 19 E) 20

YÖS

9

59.

	I	II	III
	K	3	1
	3	L	4
	2	3	M

$$\Rightarrow K = ? ; L = ? ; M = ?$$

Yukarıdaki tabloya göre K, L ve M kaçtır?

According to the table above, what are the value of K, L and M, respectively?

- A) 4; 3; 2 B) 3; 4; 2 C) 2; 3; 4
D) 3; 3; 2 E) 3; 2; 2

60.

★	★	○	◆
★	□	☉	★
☉	○	○	▲
▲	□	☉	☉

I	II
M	T
K	L
K	M

$$\Rightarrow T ; L = ?$$

I ve II yukarıdaki tablonun farklı birer parçasıdır.

Buna göre, T ve L aşağıdakilerden hangisidir?

I and II are different parts of the table above.

Accordingly, which of the following does T and L stand for?

- A) ☉ ; ○ B) ★ ; □ C) ○ ; □
D) ☉ ; ★ E) □ ; ▲

61.

	I	II	III
	K	1	1
	2	L	2
	1	2	M

$$\Rightarrow K = ? ; L = ? ; M = ?$$

Yukarıdaki tabloya göre K, L ve M kaçtır?

According to the table above, what are the value of K, L and M, respectively?

- A) 3 ; 2 ; 4 B) 2 ; 3 ; 2 C) 3 ; 2 ; 2
D) 2 ; 1 ; 2 E) 3 ; 2 ; 1

K U A R K Y A Y I N L A R I

K U A R K P U B L I C A T I O N S

YÖS

9

62.

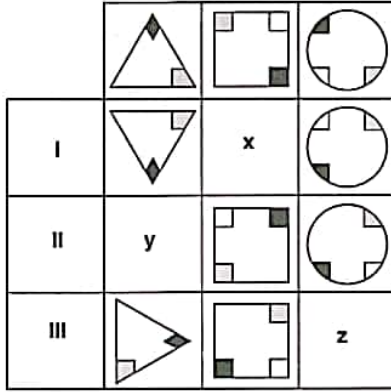
 $\Rightarrow x = ? ; y = ? ; z = ?$

Yukarıdaki tabloya göre x, y ve z yerine aşağıdaki şekillerden hangisi gelmelidir?

According to the table above, which of the following figures does x, y and z stand for?

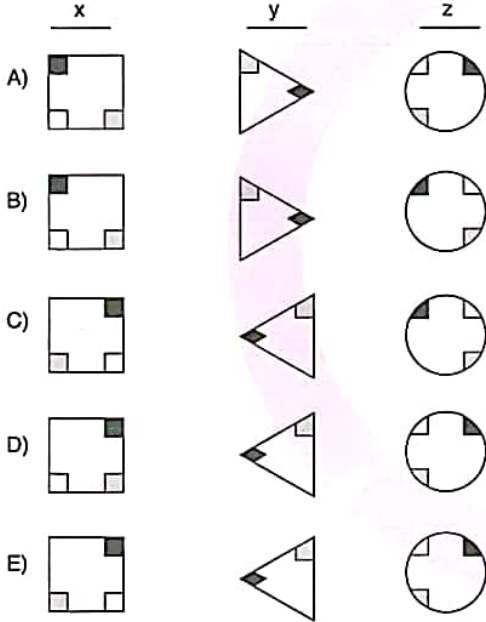

63. Aşağıdaki şekillerden hangisi bir özelliğine göre diğerlerinden farklıdır?

Which of the following figures is different than the others according to a certain property?

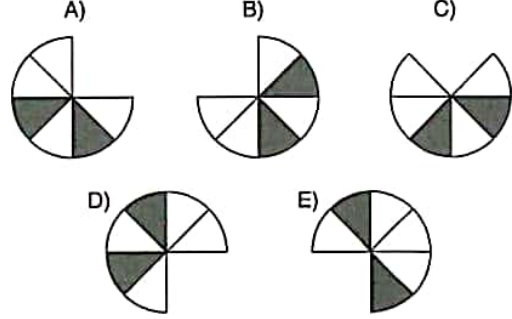

64, 65 ve 66. sorularda, verilen her bir şekil dizisindeki soru işaretinin yerine hangi şeklin getirilmesi gerektiğini bulunuz.

In questions 64, 65 and 66 find the figure which should replace the question mark in each given figure sequence.

64.

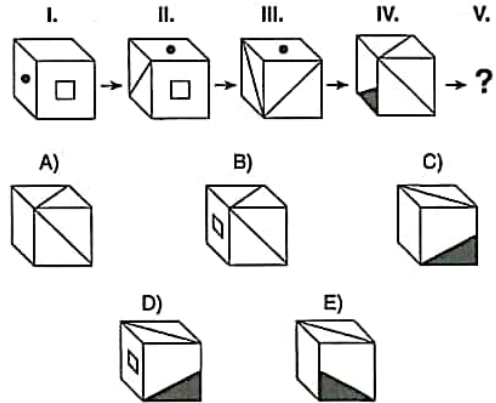

YÖS

9

65.

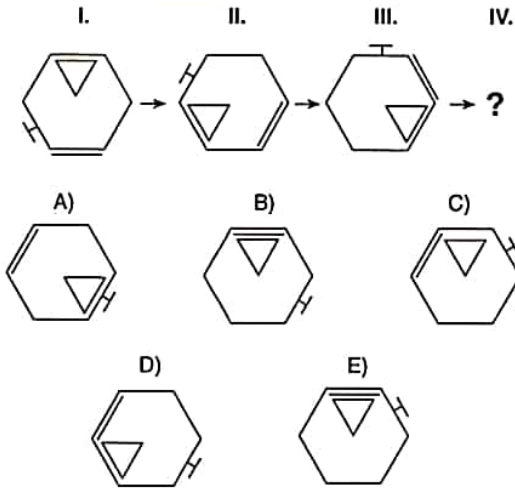

67, 68, 69 ve 70. sorularda, verilen her bir şekil matrisindeki soru işaretinin yerine hangi şeklin getirilmesi gerektiğini bulunuz.

In questions 67, 68, 69 and 70, find the figure which should replace the question mark in each given figure matrix.

67.

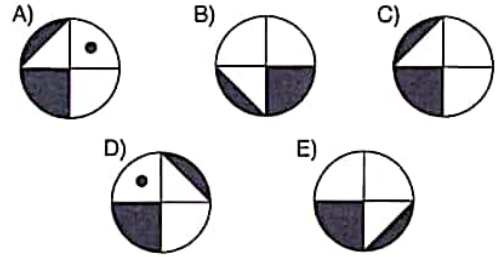
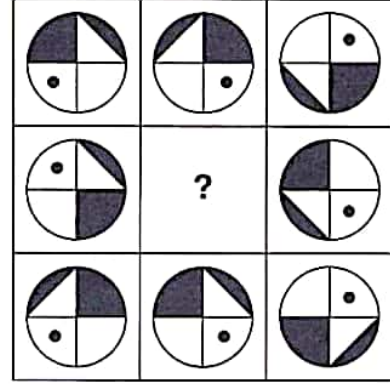

66.

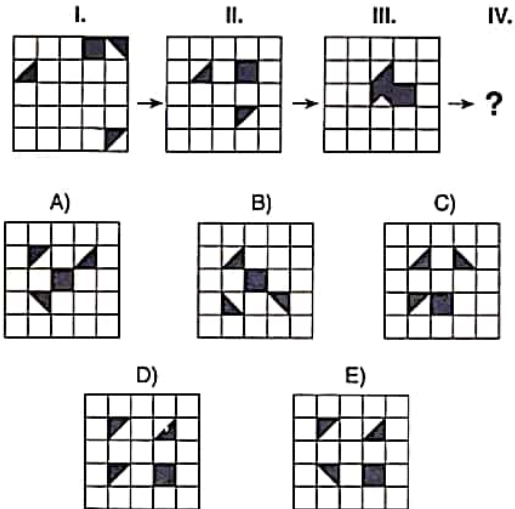

K U A R K Y A Y I N L A R I

K U A R K P U B L I C A T I O N S

YÖS

9

68.

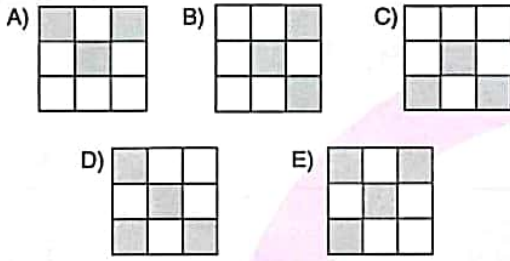
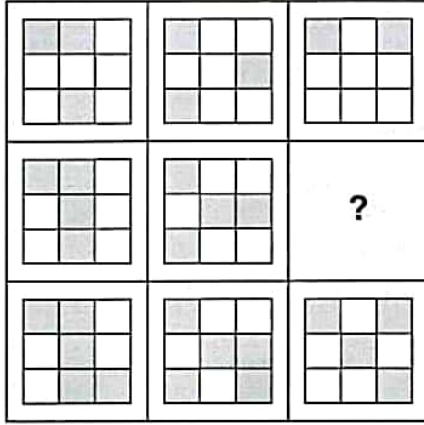

69.

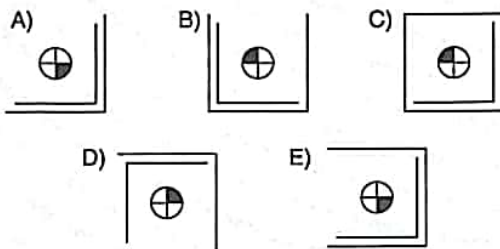
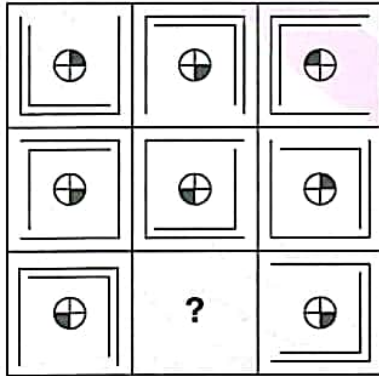

70.

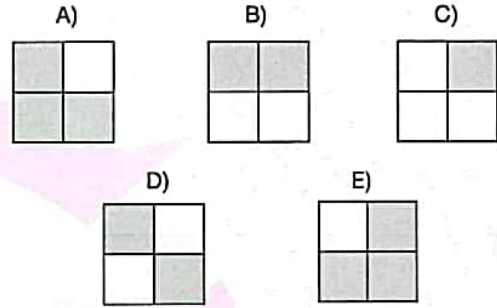
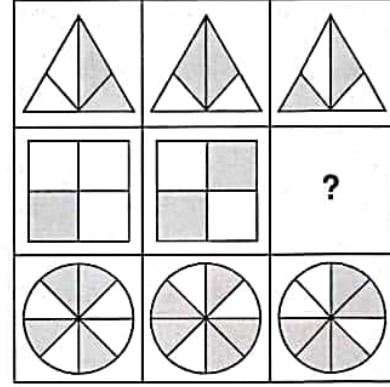

71, 72 ve 73. sorularda, I. satırda belirlenen ilişkiye göre II. satırı hangi şeklin tamamladığını bulunuz.

In questions 71, 72 and 73, find the figure which completes row II, in accordance with the relation established in row I.

71.

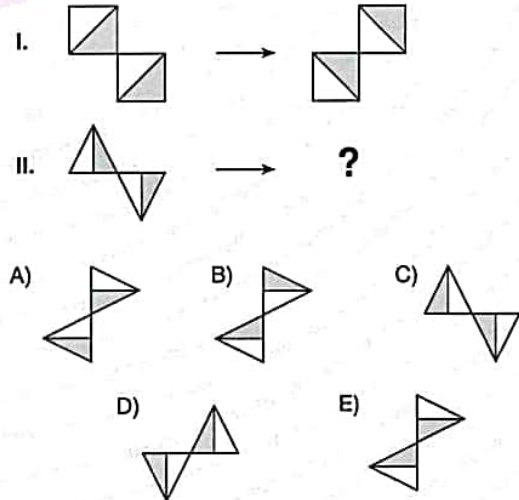

YÖS

9

72.

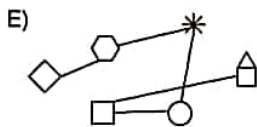
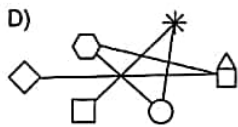
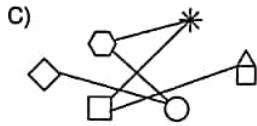
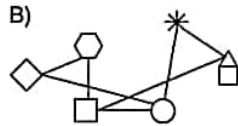
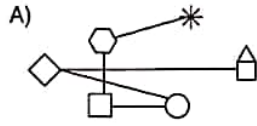
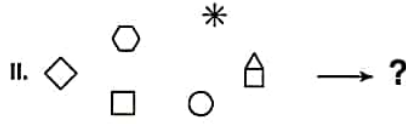
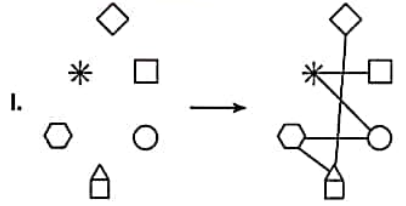

73.

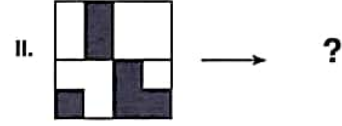
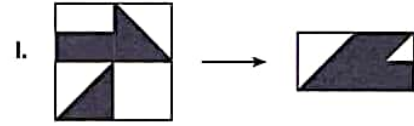

74.

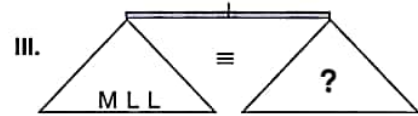
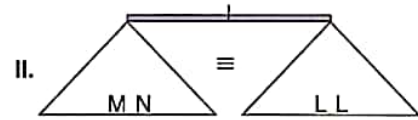
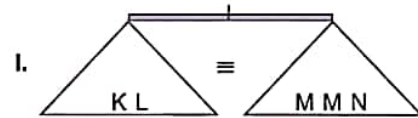

Yukarıdaki terazilerin üçü de dengededir. Buna göre, III. terazideki soru işaretini aşağıdakilerden hangisi göstermektedir?

All three scales above are in balance. Accordingly, which of the following does the question mark stand for in the third scale?

- A) K B) MN C) MM D) MMN E) NNK

K U A R K Y A Y I N L A R I

K U A R K P U B L I C A T I O N S

YÖS

9

75.

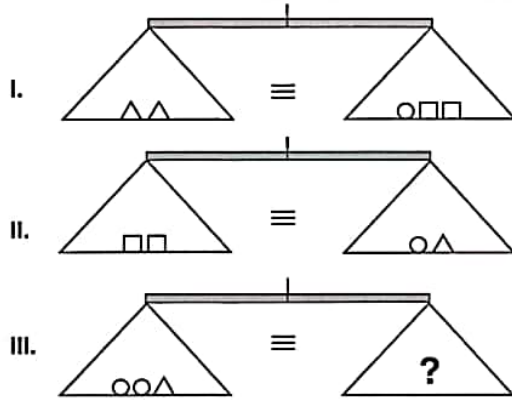

Yukarıdaki terazilerin üçü de dengededir. Buna göre, III. terazideki soru işaretini aşağıdakilerden hangisi göstermektedir?

All three scales above are in balance. Accordingly, which of the following does the question mark stand for in the third scale?

- A) Δ B) $\Delta\Delta$ C) $\Delta\Delta\Delta$
 D) $\Delta\Delta\Delta\Delta$ E) $\Delta\Delta\Delta\Delta\Delta$

76 ve 77. soruları aşağıdaki örnekte verilen ilişkiye göre cevaplayınız.

Answer questions 76 and 77, in accordance with the relation established in the example below.

ÖRNEK / EXAMPLE:

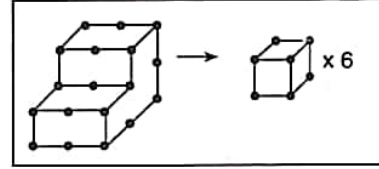

76.

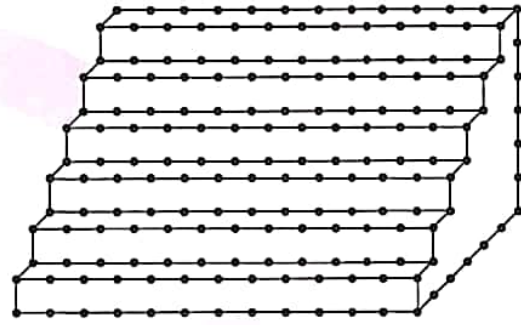

- A) 250 B) 251 C) 252 D) 253 E) 254

77.

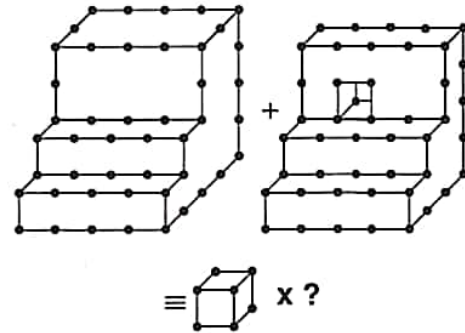

- A) 70 B) 71 C) 72 D) 73 E) 74

K U A R K Y A Y I N L A R I

K U A R K P U B L I C A T I O N S

78.

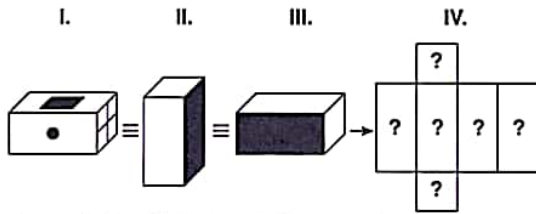

Yukarıdaki şekillerin tümü aynı prizmayı göstermektedir. Buna göre, aşağıdakilerden hangisi bu prizmanın açılmış halidir?

The figures above represent the same prism.

Accordingly, which of the following represents the unfolded form of this prism?

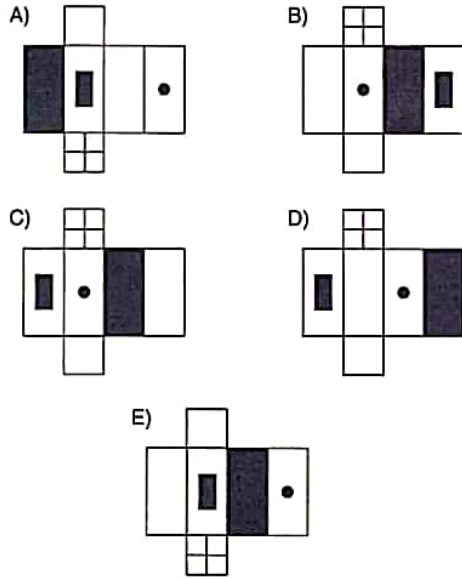

79.

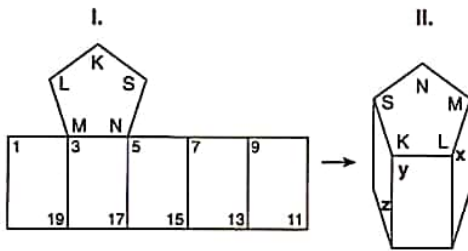

$$\Rightarrow x; y; z = ?$$

II. şekildeki cisim, I. şeklin kapalı halidir. Buna göre, II. şekildeki x, y ve z aşağıdakilerden hangisidir?

The object in figure II is the closed form of figure I.

Accordingly, which of the following stands for x, y and z in figure II?

- A) 7 ; 5 ; 11 B) 5 ; 3 ; 17 C) 7 ; 9 ; 13
D) 1 ; 9 ; 13 E) 1 ; 7 ; 11

80.

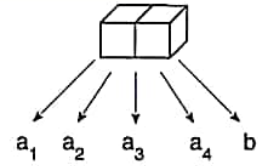

$$a_1 = a_2 = a_3 = a_4 \neq b \Rightarrow b = ?$$

Aşağıdakilerden hangisi yukarıda verilen nesnenin açılımlarından biri değildir?

Which of the following does not represent the unfolded form of the object given above?

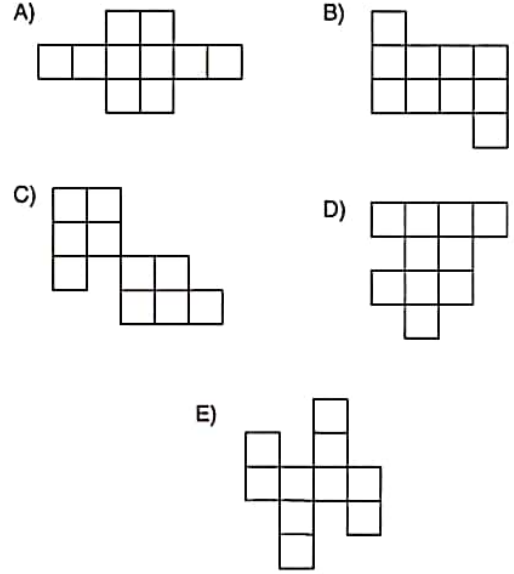

1. $m(\widehat{BAC}) = m(\widehat{BDE})$,
 $IEBI = 3 \text{ br}(u)$,
 $IBDI = 4 \text{ br}(u)$,
 $IDCI = 5 \text{ br}(u)$,
 $IACI = 12 \text{ br}(u)$
 $\Rightarrow IEDI = x = ? \text{ br}(u)$

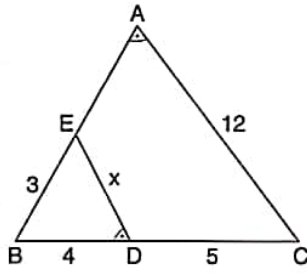

- A) 3 B) 4 C) 5 D) 6 E) 7

3.

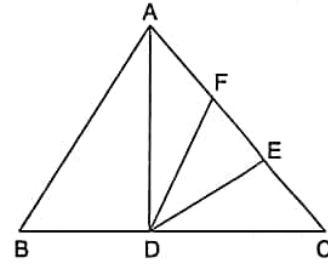

$IAFI = 2 \cdot IFEI = 2 \cdot IEIC$,
 Taralı alan / The shaded area = 12 cm^2

$\Rightarrow A(\widehat{ABC}) = ? \text{ br}^2(u^2)$

- A) 48 B) 54 C) 60 D) 72 E) 80

2.

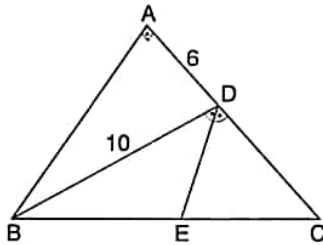

$m(\widehat{BDE}) = m(\widehat{EDC})$, $IABI = IACI$, $[BA] \perp [AC]$,
 $IADI = 6 \text{ br}(u)$, $IBDI = 10 \text{ br}(u)$
 \Rightarrow Taralı alan / The shaded area = $? \text{ br}^2(u^2)$

- A) 6 B) $\frac{19}{3}$ C) $\frac{20}{3}$ D) 7 E) $\frac{22}{3}$

4.

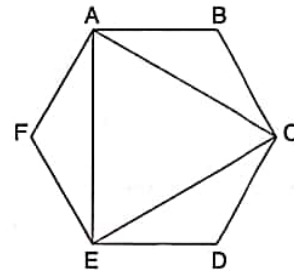

ABCDEF düzgün bir altgendir. / ABCDEF is a regular hexagon.

Taralı alan / The shaded area = $36\sqrt{3} \text{ cm}^2$

\Rightarrow Çevre / The perimeter (ABCDEF) = $? \text{ cm}$

- A) $4\sqrt{3}$ B) 24 C) $24\sqrt{3}$
 D) 36 E) 72

YÖS

10

5.

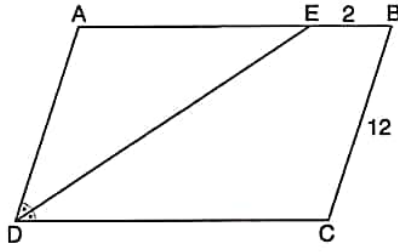

[AB] // [DC],

[AD] // [BC],

 $m(\widehat{ADE}) = m(\widehat{EDC})$,

|EB| = 2 cm,

|BC| = 12 cm

⇒ Çevre / The perimeter (ABCD) = ? cm

A) 48 B) 50 C) 52 D) 54 E) 56

6.

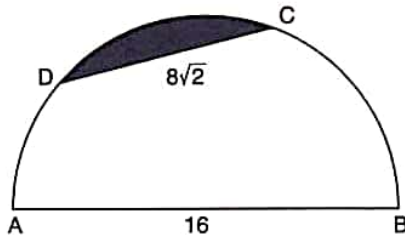

Yukarıdaki yarım dairenin çapı 16 br (u),

|DC| = $8\sqrt{2}$ br (u) olduğuna göre taralı alan kaç br^2 (u^2) dir?

If the diameter of the semi-circle above is 16 u,

|DC| = $8\sqrt{2}$ u, how many u^2 is the area of the shaded region?A) $16\pi - 32$ B) $16\pi - 16$ C) $8\pi - 48$ D) $32\pi - 48$ E) $16\pi - 24$ 7. $(AB), (BA) \in \mathbb{N}$, $AB - 2 \cdot BA = 21$ ⇒ $A + B = ?$

A) 6 B) 7 C) 8 D) 9 E) 12

K
U
A
R
K
Y
A
Y
I
N
L
A
R
I

$$8. \quad \frac{7A4B}{2} \Big| \frac{5}{1} \quad \frac{7A4B}{1} \Big| \frac{9}{1} \Rightarrow \sum A = ?$$

A) 5 B) 7 C) 9 D) 12 E) 14

K
U
A
R
K
P
U
B
L
I
C
A
T
I
O
N
S

$$9. \quad 1 + \frac{3}{\frac{2}{x+1} - 1} = 4 \Rightarrow x = ?$$

A) -2 B) -1 C) 0 D) 1 E) 2

YÖS

10

10. $(0, \overline{23} + \frac{2}{33}) : \frac{29}{11} = ?$

- A) $\frac{1}{3}$ B) $\frac{1}{6}$ C) $\frac{5}{6}$ D) $\frac{2}{3}$ E) $\frac{1}{9}$

11. $2^{2x-1} = \frac{1}{4}$,

$A = 2^{\frac{1}{2-x}} \Rightarrow A = ?$

- A) -2 B) $-\frac{1}{4}$ C) $\frac{1}{4}$ D) 2 E) 4

12. $f(x+y) = 2 \cdot f(x) \cdot f(y)$,
 $f(2) = 4 \Rightarrow f(8) = ?$

- A) 2^{13} B) 2^{12} C) 2^{11} D) 2^{10} E) 2^9

13. Köşeleri şekilde görülen 7 nokta üzerinde olan üçgenler çiziliyor.

Rastgele seçilen bir üçgenin üç kenarının da kiriş olma olasılığı kaçtır?

7 points are given as described in the figure.

Triangles are to be drawn through these points as the vertices. A triangle is chosen among them randomly. What is the probability that all of the three sides of this triangle are chords?

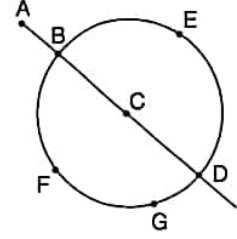

- A) $\frac{2}{7}$ B) $\frac{10}{31}$ C) $\frac{1}{3}$ D) $\frac{12}{31}$ E) $\frac{5}{7}$

14. $\frac{3x^2y^2 + 3xy^2}{x^2 - 1} : \frac{3y^2 + xy^2}{x^2 + 2x - 3} = ?$

- A) 2 B) 3 C) x D) 2x E) 3x

K U A R K Y A Y I N L A R I

K U A R K P U B L I C A T I O N S

YÖS

10

15. $\frac{a}{b} = \frac{c}{4} = \frac{3}{d}$,
 $\frac{a^2+c^2}{b^2+16} = \frac{1}{121} \Rightarrow d = ?$
 A) 30 B) 33 C) 36 D) 42 E) 45

17.

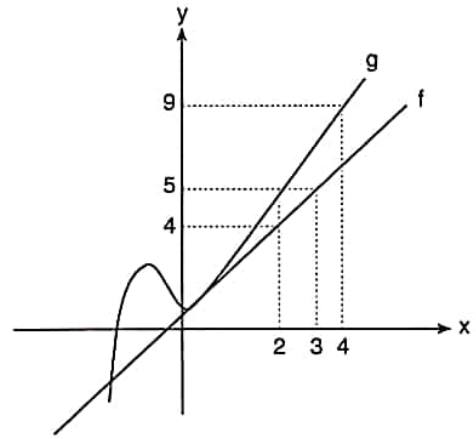

$$(g \circ f)^{-1}(x-2) = (g^{-1} \circ f)(3) \Rightarrow x = ?$$

- A) 7 B) 8 C) 9 D) 10 E) 11

K U A R K Y A Y I N L A R I

K U A R K P U B L I C A T I O N S

16. $x < 0$
 $\Rightarrow |2x| - 3|x| + |4-x| - 6|x| = ?$
 A) 4 B) x C) 2x D) 3x E) 4x

18. $n(A \cup B) + n(A \cap B) = 23$,
 $n(A) = 15 \Rightarrow n(B) = ?$
 A) 3 B) 4 C) 6 D) 8 E) 10

YÖS

10

19.

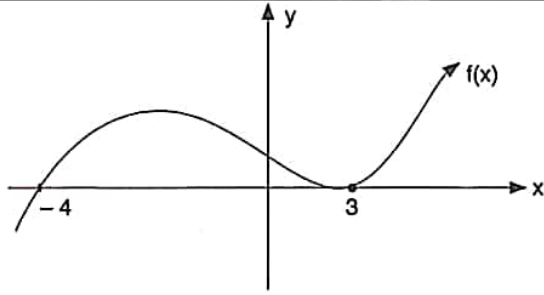

$$f(x) \cdot (x+3) \leq 0 \Rightarrow \text{ÇK(SS)} = ?$$

- A) \mathbb{R} B) $[-4, -3]$ C) $(-4, -3)$
D) $[-4, -3] \cup \{3\}$ E) \emptyset

20.

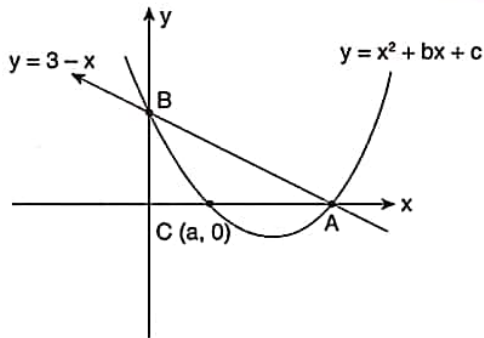

$$C(a, 0) \\ \Rightarrow a = ?$$

- A) 1 B) 2 C) $2\sqrt{2}$ D) 3 E) $3\sqrt{2}$

$$21. \left(\frac{2}{x} - x^2\right)^7 = \dots + Ax^8 + \dots \Rightarrow A = ?$$

- A) -84 B) -48 C) 18 D) 48 E) 84

$$22. x \in \mathbb{Z},$$

$$\frac{(x+3)^{57} \cdot (x-5)^{62}}{(2-x)^{55}} \geq 0 \Rightarrow \sum x = ?$$

- A) -3 B) -2 C) 0 D) 2 E) 3

$$23. O \text{ noktası çemberin merkezidir.}$$

The point O is the center of the circle.

$$|OC| = 16,$$

$$\sin(\hat{A}) + \sin(\hat{B}) + \sin(\hat{C}) = \frac{3}{2}$$

$$\Rightarrow \text{Çevre / The perimeter}(\hat{ABC}) = ?$$

- A) 16 B) 24 C) 32 D) 48 E) 64

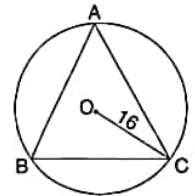

YÖS

10

24. ABCD bir karedir.
ABCD is a square.
 $2 \cdot |AE| = |EB|$,
 $m(\widehat{EFB}) = \alpha$
 $\Rightarrow \tan \alpha = ?$

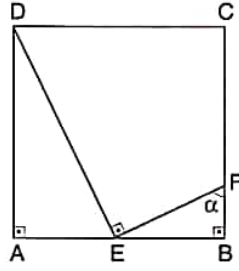

- A) $\frac{1}{3}$ B) $\frac{1}{2}$ C) 1 D) 2 E) 3

25. $f(x) = \log_3^{(x+1)} + 4$
 $\Rightarrow f^{-1}(x) = ?$

- A) $3^{x-2} + 1$ B) $3^{x-3} - 1$ C) $3^{x+3} + 1$
D) $3^{x-4} - 1$ E) $3^{x+2} + 1$

26. $\sum_{k=1}^{\infty} 2^{-k+1} = ?$

- A) $\frac{1}{2}$ B) $\frac{1}{3}$ C) $\frac{2}{3}$ D) 1 E) 2

27. $f(x) = \begin{cases} x^2 + 2, & x \neq 2 \\ x, & x = 2 \end{cases} \Rightarrow \lim_{x \rightarrow 2} = ?$

- A) 2 B) 4 C) 6 D) 8 E) 10

- 28.

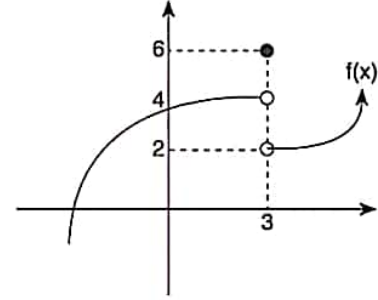

$$\Rightarrow \lim_{x \rightarrow 2^+} f(x+1) + f(3) = ?$$

- A) 2 B) 6 C) 8 D) 10 E) 11

29. $f(x) = \cos^2(5x) - \sin^2(5x)$

$$\Rightarrow f'\left(\frac{\pi}{5}\right) = ?$$

- A) -10 B) -5 C) 0 D) 5 E) 10

K U A R K Y A Y I N L A R I

K U A R K P U B L I C A T I O N S

YÖS

10

30.

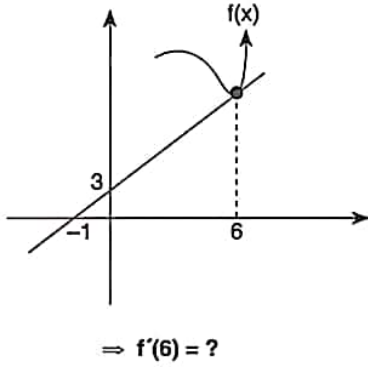

- A) $-\frac{1}{3}$ B) $-\frac{2}{3}$ C) 0 D) 2 E) 3

31. $f(x) = x^3 + 2x - 1$ olmak üzere,If $f(x) = x^3 + 2x - 1$,

$$\lim_{x \rightarrow 1} \frac{f(x) - f(1)}{1 - x} = ?$$

- A) -5 B) -3 C) 3 D) 5 E) 6

32. $\int \left[\frac{d}{dx} (\ln x) \right] dx = ?$

- A) 0 B) $\frac{x^2}{2}$ C) $\ln x + c$ D) $\frac{1}{x}$ E) $\ln x$

33.

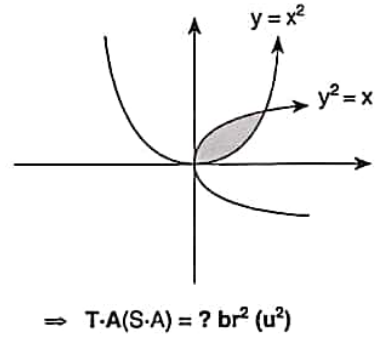

- A) $\frac{1}{6}$ B) $\frac{1}{4}$ C) $\frac{1}{3}$ D) 1 E) $\frac{2}{3}$

34. $\int_{-4}^0 \sqrt{16 - x^2} dx = ?$

- A) π B) 2π C) 3π D) 4π E) 6π

35. $A = \begin{bmatrix} 3 & 4 \\ 6 & 2 \end{bmatrix} \Rightarrow A + A^T = ?$

- A) $\begin{bmatrix} 6 & 10 \\ 10 & 4 \end{bmatrix}$ B) $\begin{bmatrix} 6 & 8 \\ 8 & 6 \end{bmatrix}$ C) $\begin{bmatrix} 6 & 10 \\ 8 & 4 \end{bmatrix}$
D) $\begin{bmatrix} 8 & 10 \\ 8 & 6 \end{bmatrix}$ E) $\begin{bmatrix} 6 & 10 \\ 10 & 12 \end{bmatrix}$

YÖS

10

36, 37, 38 ve 39. sorularda I. gruptaki her bir harf, rakam veya şekil, II. gruptaki farklı birer harf, rakam veya şekil ile gösterilmiştir.

Buna göre, soru işaretiyle belirtilen harfleri, rakamları veya şekilleri bulunuz.

In questions 36, 37, 38 and 39 each letter, numeral or figure in group I stand for a different letter, numeral or figure in group II. Accordingly, find the letters, numerals or figures which the questions mark stands for.

36.

I.	II.
K İ A	▲ ● ■
R A S	□ △ ●
İ K A	● ■ △
R O S	△ □ ●
O S İ	▲ ● ■

⇒ İ K A = ?

- A) ▲ ● ■ B) ● ■ □ C) ▲ ● ■
D) □ △ ● E) △ □ ●

37.

I.	II.
■ ● ▲ ■	5 7 4 3
▼ ■ ● ▲	7 5 4 5
● ▲ ● ▼	7 4 3 7
■ ▼ ● ▼	4 3 4 5
▲ ■ ▼ ●	3 7 5 4

⇒ 3754 = ?

- A) ▲ ■ ▼ ● B) ■ ▼ ● ▼ C) ● ▲ ■ ▼
D) ▼ ■ ● ▲ E) ■ ● ▲ ■

38.

I.	II.
B D A C	5 7 3 1
F B E A	2 5 4 3
C E B D	3 1 2 5
A C F B	1 4 5 7
D F C E	4 3 7 2

⇒ CEBD = ?

- A) 5731 B) 2543 C) 3125
D) 1457 E) 4372

39.

I.	II.
A B C D E	2 4 6 7 1
F B C D G	8 4 6 7 5
A B D F K	8 4 3 4 2
A B C F D	2 4 6 8 7
F B L B A	2 4 7 8 9

⇒ ABDFK = ?

- A) 84675 B) 84342 C) 24671
D) 24687 E) 24789

K U A R K Y A Y I N L A R I

K U A R K P U B L I C A T I O N S

40, 41 ve 42. sorulardaki verilen işlemlerde her harf sıfırdan ve birbirinden farklı birer rakamı göstermektedir.

Buna göre, soru işareti ile belirtilen harf ya da işlemin değerini bulunuz.

In the operations which are given in questions 40, 41 and 42, each letter stands for a different non-zero numeral. Accordingly, find the value of the letter or operation indicated by the questions mark.

$$40. \quad \begin{array}{r} K 6 L \\ - 7 L K \\ \hline 1 1 6 \end{array} \quad \begin{array}{r} K M \\ + M L \\ \hline 1 1 N \end{array} \Rightarrow M + N = ?$$

- A) 8 B) 9 C) 10 D) 11 E) 12

$$41. \quad \begin{array}{r} L \\ M \\ + N \\ \hline L M \end{array} \quad \begin{array}{r} L M \\ \times M \\ \hline L L N \end{array} \Rightarrow M = ?$$

- A) 3 B) 4 C) 5 D) 6 E) 7

$$42. \quad \begin{array}{r} K L \\ + N K \\ \hline M N T \end{array} \quad \begin{array}{r} L T \\ - T L \\ \hline ? \end{array}$$

- A) 9 B) 18 C) 27 D) 36 E) 45

43. I. ■ 214 = 7
II. ■ 420 = 22
III. ■ 649 = 15
IV. ■ 715 = ?

Yukarıdaki eşitliklerde ■ işaretinin görevi verilmiştir. Buna göre, dördüncü eşitlikteki soru işaretinin yerine aşağıdaki sayılardan hangisi gelmelidir?

In the equations above, the function of is ■ given. Accordingly, which of the following numbers does the question mark stand for in the fourth equation?

- A) 54 B) 55 C) 56 D) 57 E) 58

44. I. a ♥ b = 2 · (a ♥ b) + (a · b) - (a + b)
II. 8 ♥ 6 = ?

Yukarıdaki ilk eşitlikte ♥ işaretinin görevi verilmiştir. Buna göre, ikinci eşitlikteki soru işaretinin yerine aşağıdaki sayılardan hangisi gelmelidir?

In the equations above, the function of ♥ is given. Accordingly, which of the following numbers does the question mark stand for in the second equation?

- A) -36 B) -34 C) -32 D) -30 E) -28

45. I. $a \bullet b = a^2 + b$
 II. $a \blacktriangle b = b^3 + a$
 III. $a \circ b = \sqrt{a+b}$
 IV. $(12 \blacktriangle 3) \circ (4 \bullet 9) = ?$

Yukarıdaki ilk üç eşitlikte \circ , \blacktriangle ve \bullet işaretlerinin görevleri verilmiştir. Buna göre, dördüncü eşitlikteki soru işaretinin yerine aşağıdaki sayılardan hangisi gelmelidir?

In the equations above, the functions of \circ , \blacktriangle and \bullet are given. Accordingly, which of the following numbers does the question mark stand for in the fourth equation?

- A) 5 B) 6 C) 7 D) 8 E) 9

46. I. $\frac{4+2 \cdot (a \Delta b)}{(a \Delta b)+2} = \frac{a+2}{b-2}$
 II. $(4 \Delta 10) = ?$

Yukarıdaki ilk eşitlikte Δ işaretinin görevi verilmiştir. Buna göre, ikinci eşitlikteki soru işaretinin yerine aşağıdakilerden hangisi gelmelidir?

In the equations above, the function of Δ is given. Accordingly, which of the following numbers does the question mark stand for in the second equation?

- A) -2 B) -1 C) 1 D) 2 E) 4

47, 48 ve 49. soruları aşağıdaki şekle göre cevaplayınız.

Answer questions 47, 48 and 49 in accordance with the figure given below.

Her soru birbirinden bağımsız olarak cevaplanacaktır. Each question is to be answered independently.

ÖRNEK / EXAMPLE:

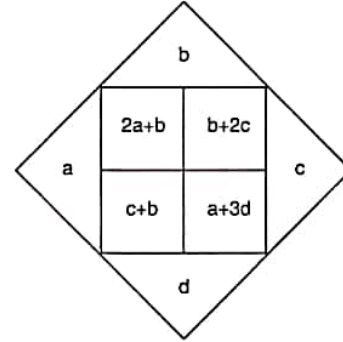

Yukarıdaki şekil a, b, c ve d harfleriyle gösterilen dört pozitif tamsayıyı içeren bazı işlemlere göre düzenlenmiştir. Harflerin gösterdiği sayılar her soruda farklı olabilir; fakat yapılacak işlemler her soruda aynıdır.

The figure above has been organized according to various operations using four positive integers represented by the letters a, b, c and d. The integers represented by the letters may change from question to question, but the operations to be done remain the same.

47.

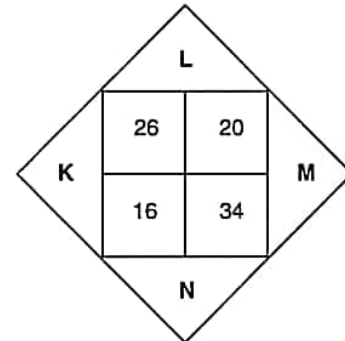

$$\Rightarrow K + L + M + N = ?$$

- A) 28 B) 30 C) 32 D) 34 E) 36

48.

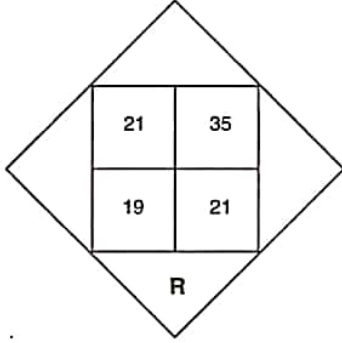

$$\Rightarrow R = ?$$

- A) 3 B) 4 C) 6 D) 14 E) 16

49.

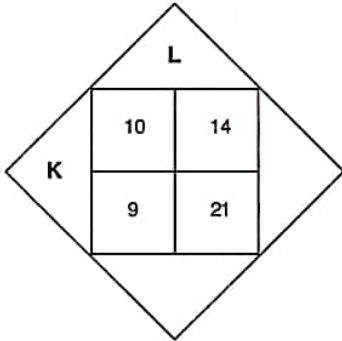

$$\Rightarrow K + L = ?$$

- A) 7 B) 8 C) 9 D) 10 E) 11

50.

+	a	b	c
a		c+1	
b			a+23
c	b+13		

$$\Rightarrow a + b + c = ?$$

Yukarıdaki toplama tablosunda a, b ve c harfleri pozitif birer tamsayının yerine kullanılmıştır. Buna göre, $a + b + c$ kaçtır?

In the summation table above, the letters a, b and c each stands for a positive integer. Accordingly, what is the value of $a + b + c$?

- A) 35 B) 36 C) 37 D) 38 E) 39

51.

x	a	b	c
a	b^3		
b	$2-c$	c	
c			

$$\Rightarrow a + c = ?$$

Yukarıdaki çarpma tablosunda a, b ve c harfleri pozitif birer tamsayının yerine kullanılmıştır. Buna göre, $a + c$ kaçtır?

In the multiplication table above, the letters a, b and c each stands for a positive integer. Accordingly, what is the value of $a + c$?

- A) 16 B) 18 C) 20 D) 22 E) 24

YÖS

10

52.

x	K	L	M
K		64	96
L			24

$$\Rightarrow K + L + M = ?$$

Yukarıdaki çarpma tablosunda K, L ve M harfleri pozitif birer tamsayının yerine kullanılmıştır. Buna göre, $K + L + M$ kaçtır?

In the multiplication table above, the letters K, L and M each stand for a positive integer. Accordingly, what is the value of $K + L + M$?

- A) 20 B) 22 C) 24 D) 26 E) 28

53.

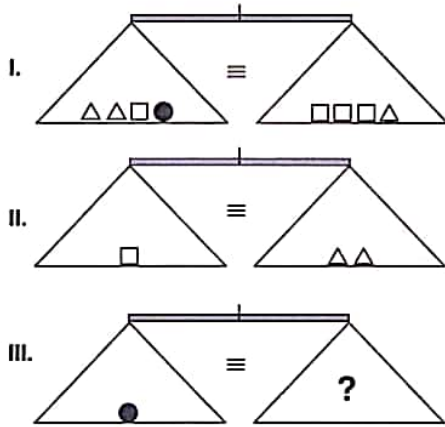

Yukarıdaki terazilerin üçü de dengede olduğuna göre, III. terazideki soru işaretini aşağıdakilerden hangisi göstermektedir?

All three scales above are in balance. Accordingly, which of the following does the question mark stand for in the third scale?

- A) Δ B) \square C) $\Delta\Delta\Delta$
D) $\square\Delta\Delta$ E) $\square\square\square$

54.

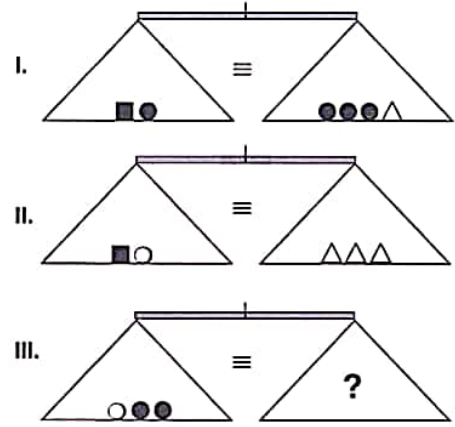

Yukarıdaki terazilerin üçü de dengede olduğuna göre, III. terazide soru işaretini aşağıdakilerden hangisi göstermektedir?

All three scales above are in balance. Accordingly, which of the following does the question mark stand for in the third scale?

- A) \square B) $\square\square$ C) $\Delta\Delta$
D) $\square\square\Delta$ E) $\square\square\square$

55.

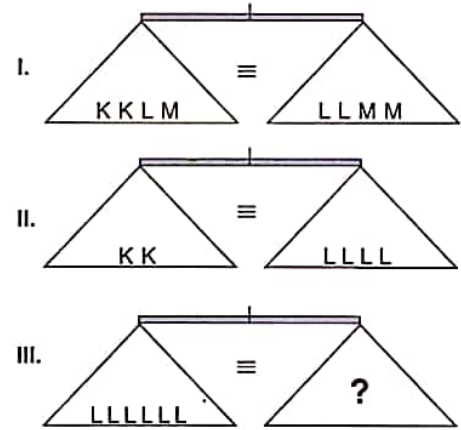

Yukarıdaki terazilerin üçü de dengede olduğuna göre, III. terazideki soru işaretini aşağıdakilerden hangisi göstermektedir?

All three scales above are in balance. Accordingly, which of the following does the question mark stand for in the third scale?

- A) M B) MM C) MMM
D) MMMM E) MMMMM

K U A R K Y A Y I N L A R I

K U A R K P U B L I C A T I O N S

YÖS

10

56.

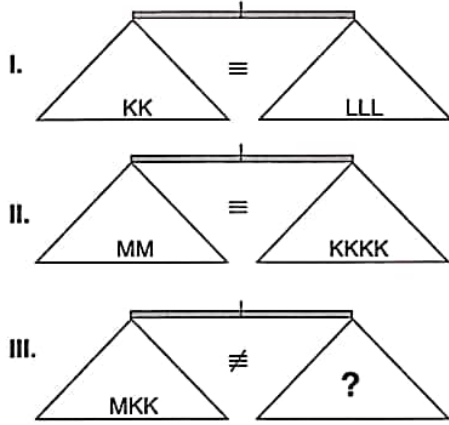

Yukarıdaki terazilerin ilk ikisi dengede olup, üçüncüsü dengede değildir. Buna göre, III. terazi-deki soru işaretini aşağıdakilerden hangisi göstermektedir?

First two scales above are in balance, the third scale is not in balance. Accordingly, which of the following does the question mark stand for in the third scale?

- A) KKKLL B) MM C) LLLKK
D) LLLLLL E) MLLL

57.

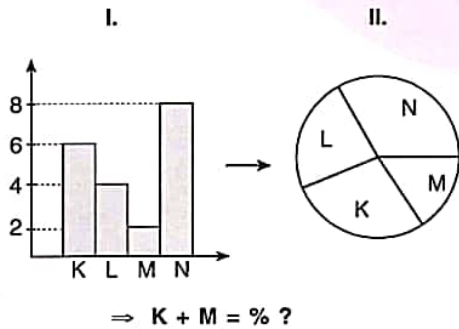

II. şekildeki dairesel grafik, I. sütun grafikte verilen bilgilere göre düzenlenmiştir. Buna göre K + M yüzde kaçtır?

The circular chart in figure II is organised according to the information in the column chart in figure I. Accordingly, what is the percentage of K + M?

- A) 25 B) 30 C) 35 D) 40 E) 45

58.

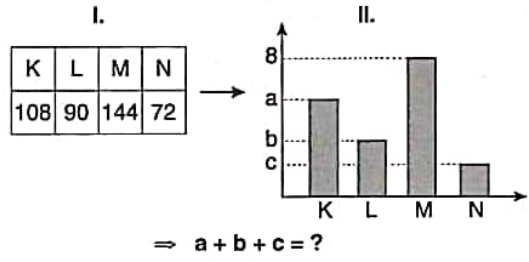

II. şekildeki sütun grafik, I. şekildeki tabloya göre düzenlenmiştir. Buna göre $a + b + c$ kaçtır?

The column chart in figure II is organised according to the table in figure I. Accordingly, what is the value of $a + b + c$?

- A) 14 B) 15 C) 16 D) 17 E) 18

K U A R K Y A Y I N L A R I

K U A R K P U B L I C A T I O N S

YÖS

10

59.

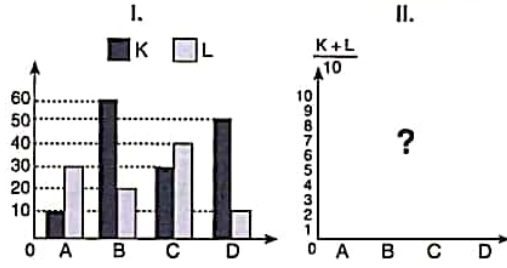

Yukarıdaki birinci sütun grafikte verilen bilgilere göre, ikinci grafik aşağıdakilerden hangisidir?

According to the information in the first column chart above, which of the following does the second chart stand for?

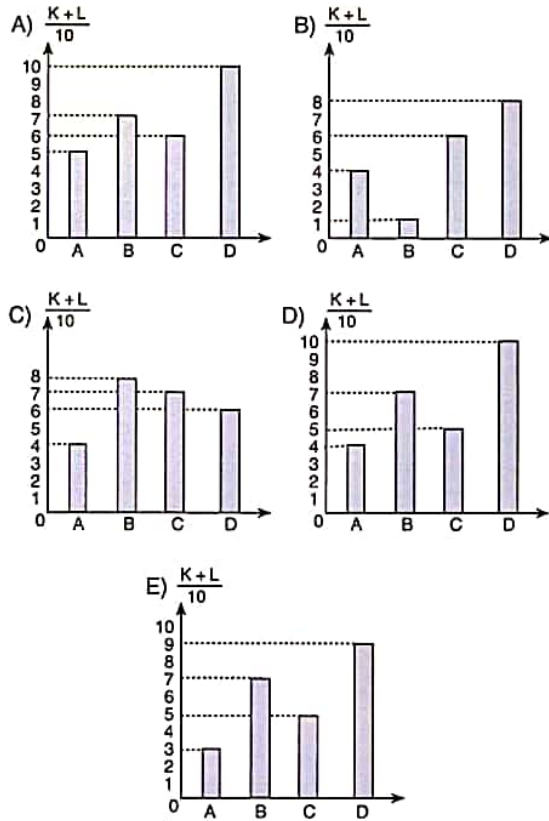

60.

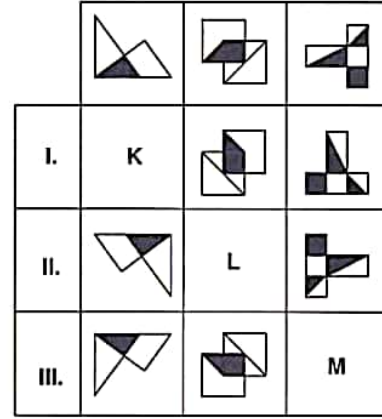

$\Rightarrow K = ?; L = ?; M = ?$

Yukarıdaki tabloya göre K, L ve M aşağıdakilerden hangisidir?

According to the table above which of the following stands for K, L and M?

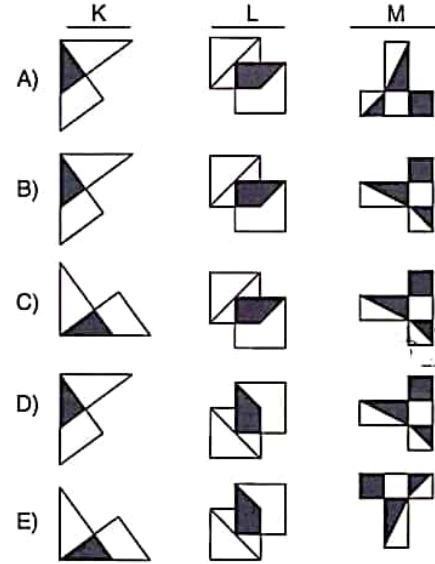

YÖS

10

61.

I.	2	K	3
II.	4	2	L
III.	M	4	6

 $\Rightarrow K = ?; L = ?; M = ?$

Yukarıdaki tabloya göre K, L ve M kaçtır?

According to the table above, what are the value of K, L and M?

	K	L	M
A)	2	3	4
B)	3	1	2
C)	4	2	2
D)	6	3	2
E)	2	2	2

62, 63 ve 64. sorularda, verilen her bir şekil matrisindeki soru işaretinin yerine hangi şeklin getirilmesi gerektiğini bulunuz.

In questions 62, 63 and 64 find the figure which should replace the question mark in each given figure matrix.

62.

		?

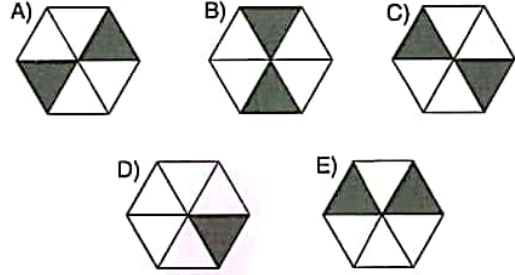

63.

13	29	18
58	36	23
82	66	?

- A) 20 B) 21 C) 22
- D) 23 E) 24

K U A R K Y A Y I N L A R I

K U A R K P U B L I C A T I O N S

YÖS

10

64.

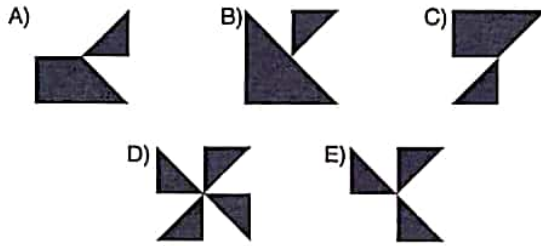
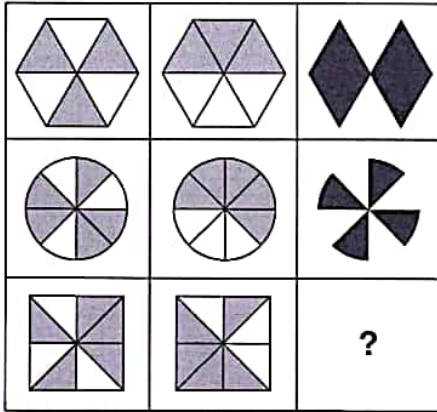

65, 66 ve 67. sorularda, I. ve II. satırda belirlenen ilişkiye göre III. satırı hangi şeklin tamamladığını bulunuz.

In questions 65, 66 and 67 find the figure which completes row III, in accordance with the relation established in row I and II.

65.

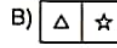
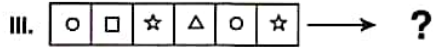
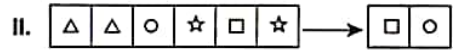
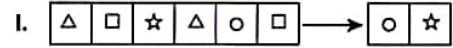

66.

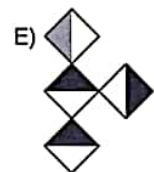
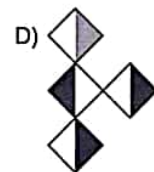
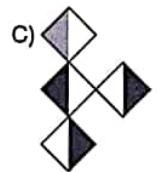
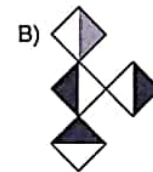
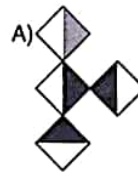
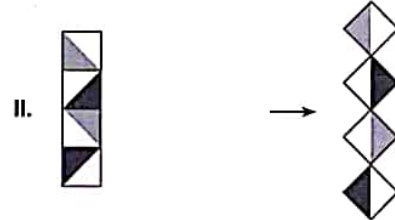
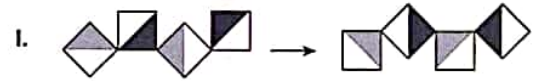

YÖS

10

67.

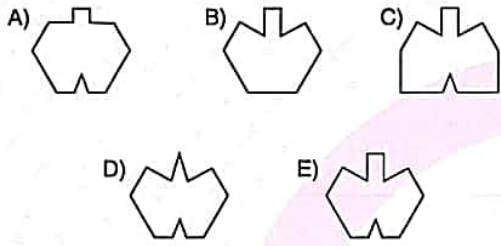
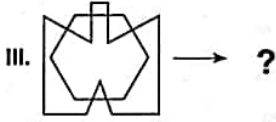
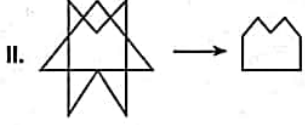
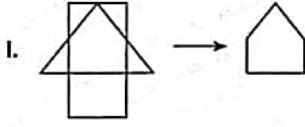

68 ve 69. sorularda, I. satırda belirlenen ilişkiye göre II. satırı hangi şeklin tamamladığını bulunuz.

In questions 68 and 69 find the figure which completes row II, in accordance with the relation established in row I.

68.

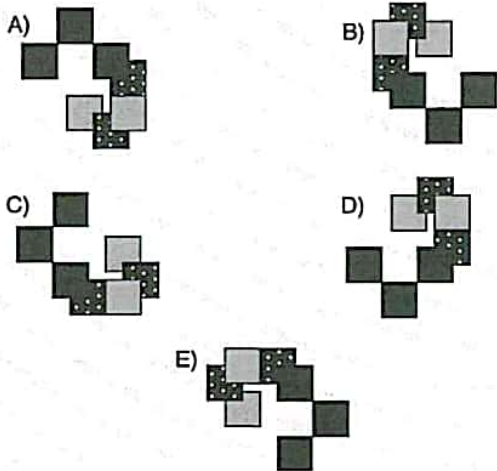
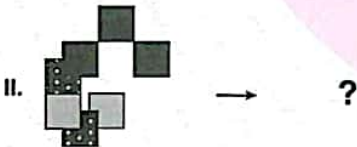
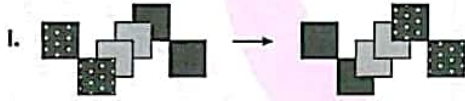

69.

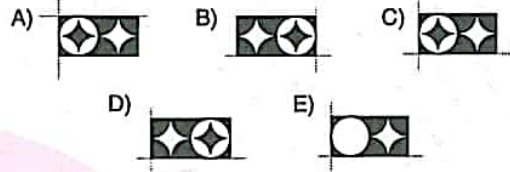
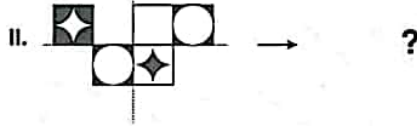
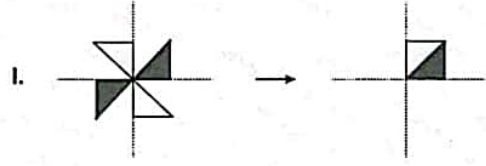

70 ve 71. sorularda, soru işaretinin yerine getirilmesi gereken şekli bulunuz.

In question 70 and 71 find the figure to replace the question mark.

70.

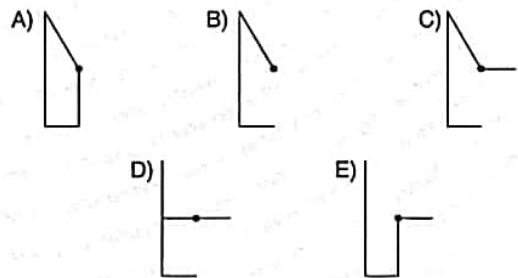
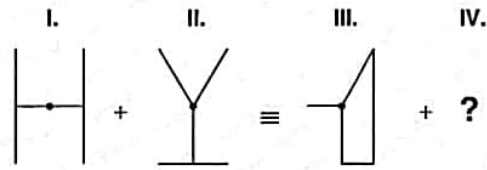

YÖS

10

71. I. II. III. IV.

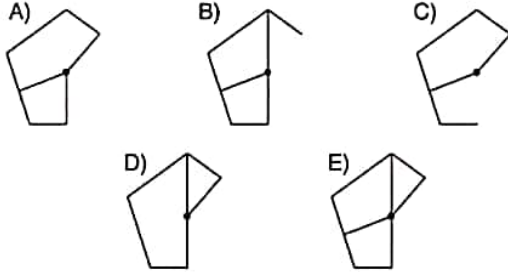
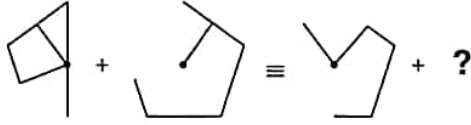

73. I. II. III. IV.

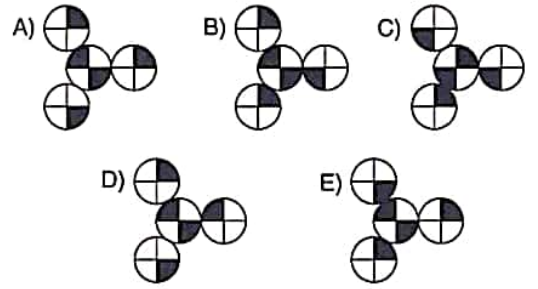
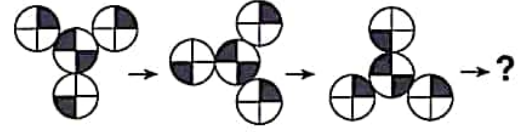

72, 73 ve 74. sorularda, verilen her bir şekil dizisindeki soru işaretinin yerine hangi şeklin getirilmesi gerektiğini bulunuz.

In questions 72, 73 and 74, find the figure which should replace the question mark in each given figure sequence.

72. I. II. III. IV.

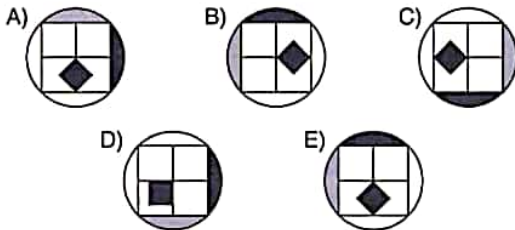
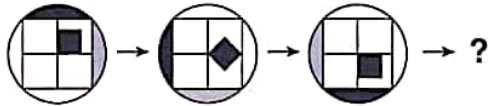

74.

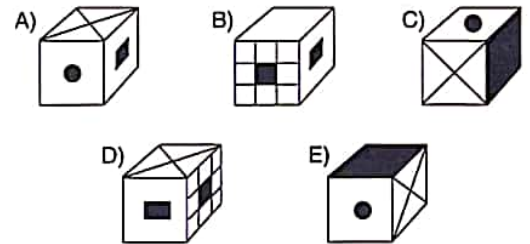
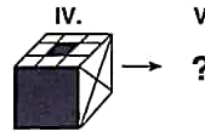
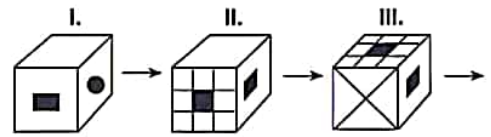

K U A R K Y A Y I N L A R I

K U A R K P U B L I C A T I O N S

YÖS

10

75.

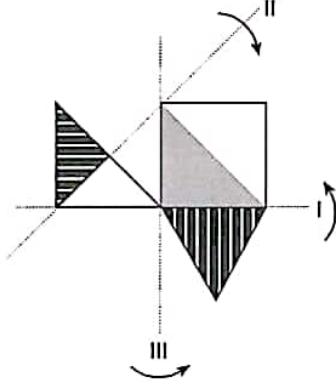

Yukarıdaki şekil sırayla önce I, sonra II, ardından da III ekseninden katlandığında aşağıdaki şekillerden hangisi oluşur?

Which of the following figures is formed when the figure is folded firstly by axis I, secondly by axis II and lastly by axis III?

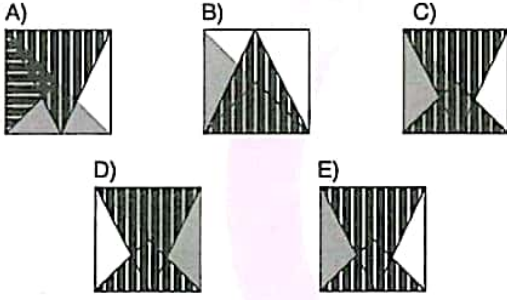

76. Aşağıdaki şekillerden hangisi belirgin bir özelliğine göre diğerlerinden farklıdır?

Which of the following figure is different then the others accordingly to its certain property?

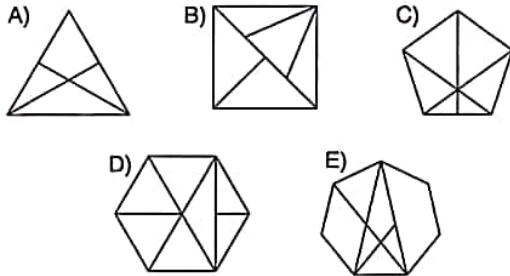

77 ve 78. soruları aşağıdaki örnekte verilen ilişkiye göre cevaplayınız.

Answer questions 77 and 78, in accordance with the relation established in the example below.

ÖRNEK / EXAMPLE:

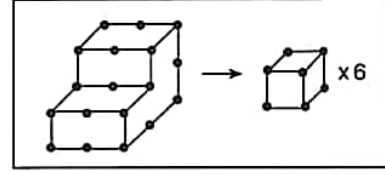

77.

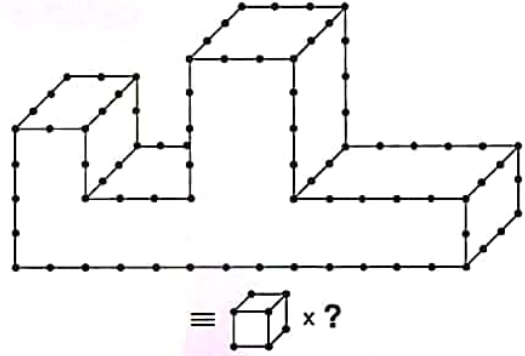

A) 124 B) 125 C) 126 D) 127 E) 128

78.

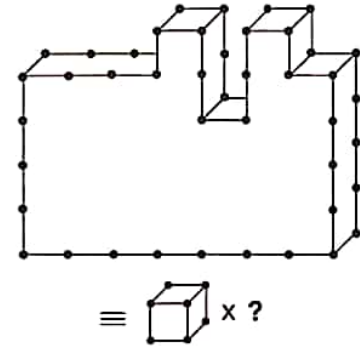

A) 27 B) 28 C) 29 D) 30 E) 31

K U A R K Y A Y I N L A R I

K U A R K P U B L I C A T I O N S

79. soruyu aşağıdaki örnekte verilen ilişkiye göre cevaplayınız.

Answer question 79 in accordance with the relation established in the example below.

ÖRNEK / EXAMPLE:

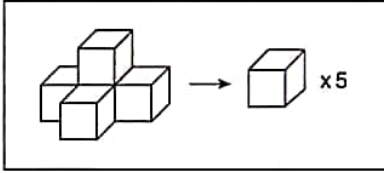

79.

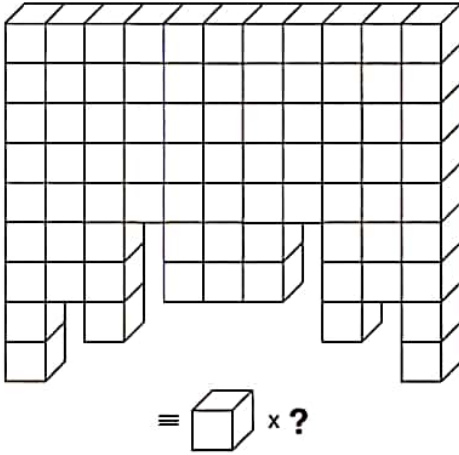

- A) 75 B) 76 C) 77 D) 78 E) 79

80.

I.

II.

III.

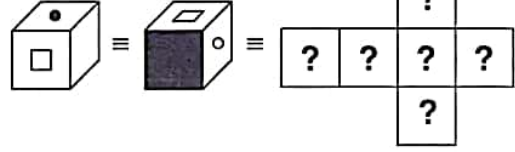

Yukarıdaki şekillerin tümü aynı küpü göstermektedir. Buna göre, aşağıdakilerden hangisi bu küpün açılmış halidir?

The figures above represent the same cube.

Accordingly, which of the following represents the unfolded form of this cube?

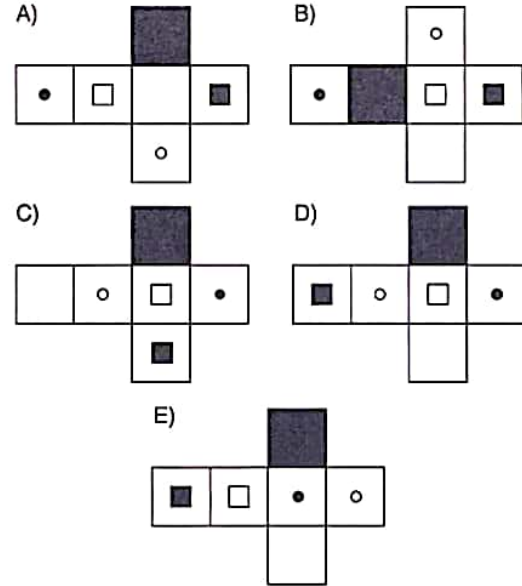

1. $\frac{-3 - (-2) + (-7)}{3 \cdot (-4)} = ?$

- A) $-\frac{2}{3}$ B) $-\frac{1}{4}$ C) $-\frac{1}{2}$ D) $\frac{1}{4}$ E) $\frac{2}{3}$

2. $\frac{A}{5} \Big| \frac{7}{x} \quad \frac{4A+3}{x} \Big| \frac{7}{x} \Rightarrow x = ?$

- A) 0 B) 1 C) 2 D) 3 E) 4

3. $\left(1 - \frac{1}{2^2}\right) \cdot \left(1 - \frac{1}{3^2}\right) \cdot \left(1 - \frac{1}{4^2}\right) \cdot \left(1 - \frac{1}{5^2}\right) = ?$

- A) $\frac{1}{5}$ B) $\frac{2}{5}$ C) $\frac{3}{5}$ D) $\frac{4}{5}$ E) 1

4. $\left(\frac{0,2-0,02}{0,9}\right) \cdot \left(\frac{2}{0,04}\right) = ?$

- A) $\frac{1}{2}$ B) $\frac{5}{2}$ C) 5 D) 10 E) 50

5. $\left. \begin{array}{l} x+y=15 \\ y+z=6 \end{array} \right\} \Rightarrow \frac{y^2 + x \cdot (y+z) + y \cdot z}{x-z} = ?$

- A) 9 B) 10 C) 12 D) 15 E) 21

6. $a, b, c \in \mathbb{Z}^+$
 $a \neq b \neq c,$
 $2a + 2b = 3c$
 $\Rightarrow \min(a + b + c) = ?$

- A) 10 B) 12 C) 18 D) 21 E) 24

7. $\frac{1}{a} + \frac{2}{b} = \frac{x}{2x-y}$

$$\frac{2}{a} + \frac{3}{b} = \frac{y}{2x-y} \Rightarrow b = ?$$

- A) -2 B) -1 C) 1 D) 2 E) 3

8. $A \in \mathbb{Z}$,

$$-3 \leq x < 3$$

$$-4 \leq y < 4$$

$$x^2 + 2y = A \Rightarrow \sum A = ?$$

- A) 100 B) 108 C) 116 D) 120 E) 136

9. $\frac{(-x)^3 \cdot (-x^2)^2 \cdot (-x^2)^{-1}}{-x^4 \cdot (-x)^{-2} \cdot (-x^2)} = ?$

- A) x B) x^{-1} C) -x D) $-x^{-1}$ E) x^{-2}

10. $\sqrt[5]{3 \cdot \sqrt[3]{x}} = \sqrt[5]{3 \cdot \sqrt[3]{2}} \Rightarrow x = ?$

- A) 2 B) 2^2 C) 2^3 D) 2^4 E) 2^5

11. $|x| < 2$

$$\Rightarrow |x-3| + |2-x| + |x+3| - 1 = ?$$

- A) $x-7$ B) $x-4$ C) $4-x$
D) $6-x$ E) $7-x$

12. $f^{-1}(5) + f(5) = ?$

- A) -2
B) -1
C) 0
D) 1
E) 2

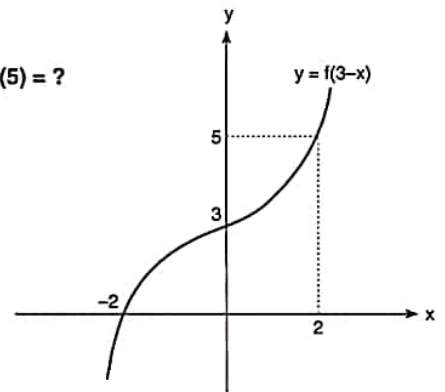

13. $(2015)^{4n+3} + 9! \equiv x \pmod{5} \Rightarrow x = ?$

- A) 0 B) 1 C) 2 D) 3 E) 4

14. $10 \cdot n(A) = 6 \cdot n(B) = 15 \cdot n(A \cap B)$
 $n(A' \cap B) = 6 \Rightarrow n(A \cup B) = ?$

- A) 8 B) 10 C) 12 D) 14 E) 16

15. $P(x+2) = x^3 - 3x^2 + ax + 3$

$$\frac{P(x-1)}{x-1} \Big|_{x=-5} \Rightarrow a = ?$$

- A) -8 B) -6 C) -3 D) 6 E) 8

16. $x \in \mathbb{Z}$,

$$\frac{(x-5)^2 \cdot (x+3)}{1-x} \geq 0 \Rightarrow \sum x = ?$$

- A) -6 B) -3 C) -2 D) -1 E) 0

K U A R K Y A Y I N L A R I

K U A R K P U B L I C A T I O N S

17.

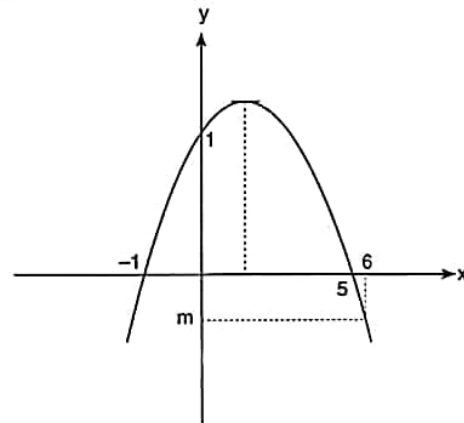

$$\Rightarrow m = ?$$

- A) $-\frac{9}{5}$ B) $-\frac{8}{5}$ C) $-\frac{7}{5}$ D) -1 E) $-\frac{4}{5}$

18.

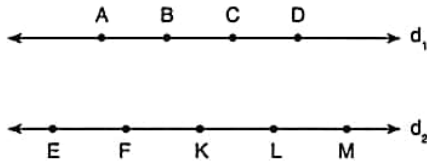

Şekildeki 9 nokta kullanılarak kaç farklı üçgen oluşturulabilir?

How many different triangles can be formed by using 9 points given in the figure?

- A) 30 B) 35 C) 45 D) 50 E) 70

20.

$$i = \sqrt{-1}$$

$$z = \frac{(\sqrt{11} + i\sqrt{5}) \cdot (4 + \sqrt{-9})}{\sqrt{3} - i} \Rightarrow |z| = ?$$

- A) 2 B) 5 C) 10 D) 12 E) 15

21.

$$\lim_{x \rightarrow \infty} \frac{3 \cdot 2^x - 2^{-x}}{2^x + 2^{-x}} = ?$$

- A) 3 B) 1 C) 0 D) -1 E) -3

19.

$$\log_2 x - 7 \cdot \log_x 2 + 6 = 0,$$

$$\text{ÇK(SS)} = \{x_1, x_2\} \Rightarrow x_1 \cdot x_2 = ?$$

- A) $\frac{1}{128}$ B) $\frac{1}{64}$ C) $\frac{1}{32}$ D) 64 E) 128

22.

$$\lim_{x \rightarrow 0} \left(\frac{x}{2} \cdot \cot 6x \right) = ?$$

- A) 3 B) $\frac{1}{12}$ C) $\frac{1}{3}$ D) $\frac{1}{6}$ E) $\frac{7}{12}$

K
U
A
R
K
Y
A
Y
I
N
L
A
R
IK
U
A
R
K
P
U
B
L
I
C
A
T
I
O
N
S

23. $\lim_{x \rightarrow a} \frac{\sin x - \cos a}{\cos x - \sin a} = ?$

- A) -1 B) $-\cot a$ C) $-\tan a$ D) $\tan a$ E) 1

24. $\cos(2\arctan 3) = ?$

- A) $-\frac{5}{6}$ B) $-\frac{4}{5}$ C) $-\frac{3}{4}$ D) $-\frac{2}{3}$ E) $-\frac{1}{2}$

25. $A = \cos 140^\circ$
 $B = \cos 200^\circ$
 $C = \sin 190^\circ$
 $D = \sin 280^\circ$
 $\Rightarrow ? < ? < ? < ?$

- A) $A < B < C < D$ B) $B < C < D < A$
 C) $B < D < C < A$ D) $D < B < A < C$
 E) $C < B < A < D$

26. $(f + g)(x) = h(x)$

$$f(x) = x^2 - 2x + 1$$

$$g(x) = x^2 + 2x - 1$$

$$\Rightarrow h'(x) = ?$$

- A) $6x$ B) $4x$ C) 0 D) $-2x$ E) $-x^2$

27. $f(x) = \int d(x^2 - 3x + 8)$
 $\Rightarrow f'(2) = ?$

- A) 1 B) $\frac{2}{3}$ C) 2 D) 3 E) 5

28. $f'(x) = 12x$

$$f(1) = 10$$

$$\Rightarrow f(2) = ?$$

- A) 20 B) 22 C) 24 D) 26 E) 28

29.

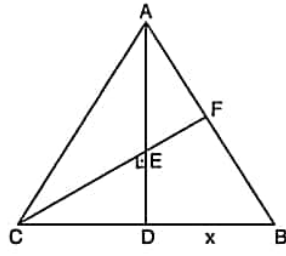

$$|AE| = |ED|$$

$$2|AF| = |FB|$$

$$|CD| = 12$$

$$\Rightarrow x = ?$$

- A) 6 B) 10 C) 12 D) 16 E) 20

30.

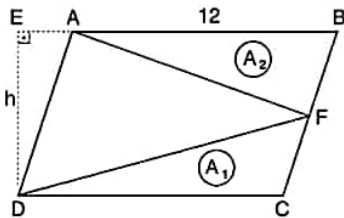

ABCD bir paralelkenardır. / ABCD is a parallelogram.

$$[AE] \perp [ED], \quad |AB| = 12 \text{ cm}, \quad A_1 = 32 \text{ cm}^2, \quad A_2 = 64 \text{ cm}^2$$

$$\Rightarrow |ED| = h = ? \text{ cm}$$

- A) 12 B) 14 C) 15 D) 16 E) 18

31.

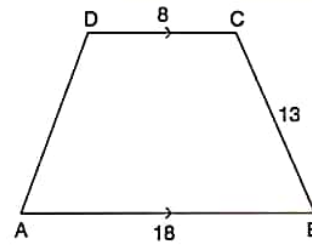

ABCD bir yamuktur. / ABCD is a trapezoid.

$$[AB] \parallel [DC], \quad |AB| = 18 \text{ cm}, \quad |BC| = 13 \text{ cm}, \quad |DC| = 8 \text{ cm}$$

$$|AD| = |BC| \Rightarrow A(\text{ABCD}) = ? \text{ cm}^2$$

- A) 100 B) 116 C) 120 D) 136 E) 156

32.

O noktası şekildeki

çemberin merkezidir.

Point O is the center of the circle in the figure.

$$|OA| = 4 \text{ br}(u),$$

$$|AB| = 5 \text{ br}(u)$$

$$\Rightarrow TA/SA = ? \pi \text{ br}^2(u^2)$$

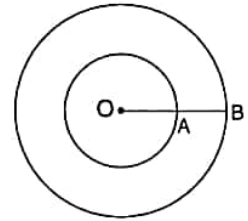

- A) 16 B) 24 C) 48 D) 65 E) 81

33.

$$[AB] \parallel [CD],$$

$$m(\widehat{BCD}) = 100^\circ,$$

$$m(\widehat{AB}) = \alpha,$$

$$m(\widehat{DC}) = \beta$$

$$\Rightarrow \alpha = ?$$

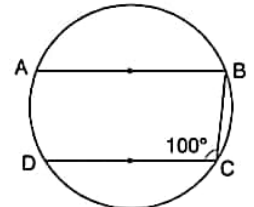

- A) 40° B) $40^\circ + \beta$ C) $45^\circ + \beta$
D) $80^\circ - \beta$ E) $60^\circ + \beta$

34. Parametrik denklemi, $x = 4 - 2k$, $y = 2 + k$ olan doğrunun grafi aşağıdakilerden hangisidir.
Which of the following is the graph of the parametric equation $x = 4 - 2k$, $y = 2 + k$.

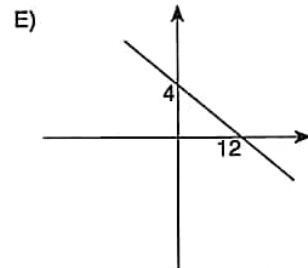
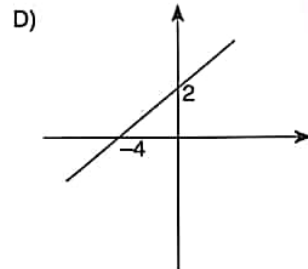
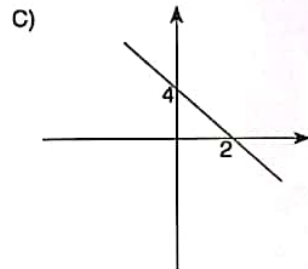
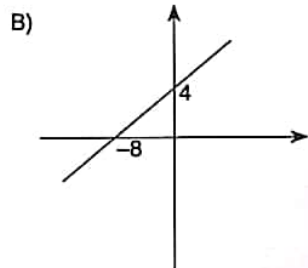
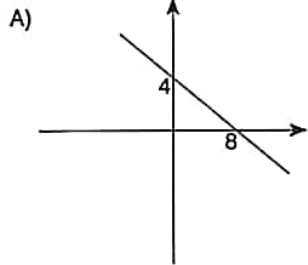

- 35.

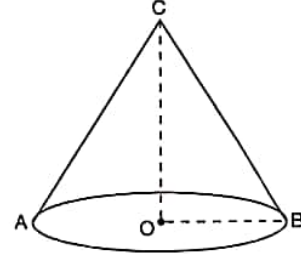

Dik dairesel koninin taban yarıçapı 3, $ICBI = 3\sqrt{3}$

The base radius of the circular right cone is 3, $ICBI = 3\sqrt{3}$

\Rightarrow koninin hacmi / Volume of the cone = ? br^3 (u^3)

- A) 12π B) 16π C) $9\pi\sqrt{2}$
D) $9\pi\sqrt{3}$ E) 24π

K
U
A
R
K
Y
A
Y
I
N
L
A
R
I

K
U
A
R
K
P
U
B
L
I
C
A
T
I
O
N
S

36, 37, 38 ve 39. sorularda I. gruptaki her bir harf, rakam veya şekil, II. gruptaki farklı birer harf, rakam veya şekil ile gösterilmiştir. Buna göre, soru işaretiyle belirtilen harfleri, rakamları veya şekilleri bulunuz.

In questions 36, 37, 38 and 39 each letter, numeral or figure in group I stand for a different letter, numeral or figure in group II. Accordingly, find the letters, numerals or figures which the questions mark stands for.

36.

I.	II.
Y A M	0 5 9
Y A S	0 5 8
N E L	3 4 8
N E S	3 4 1
L U S	9 2 8

⇒ Y A M = ?

- A) 928 B) 059 C) 058 D) 341 E) 348

37.

I.	II.
N A R A R A	2 1 7 1 7 1
K A R A R A	6 1 7 1 7 1
D A R A R A	9 1 7 1 7 1
S A R A R A	1 5 3 9 6 8
A U M N D S	8 1 7 1 7 1

⇒ K A R A R A = ?

- A) 217171 B) 617171 C) 917171
D) 153968 E) 817171

38.

I.	II.
★ + X ↗	A R G O
X ★ ⇒ +	K A T I
+ ↗ ★ ⇒	T K G R
↗ ⇒ + X	I G R T
⇒ ⇒ ★ ⇒	G T I K

⇒ ★ + X ↗ = ?

- A) TKGR B) GTIK C) ARGO
D) KATI E) IGRT

39.

I.	II.
R E Z A K	3 6 7 1 2
M İ N E Z	8 9 3 6 7
Z A K İ N	2 7 1 8 5
N K İ R M	7 8 9 5 6
K R E M A	5 1 2 9 3

⇒ Z A K İ N = ?

- A) 36712 B) 89367 C) 27185
D) 78956 E) 51293

K
U
A
R
K
Y
A
Y
I
N
L
A
R
IK
U
A
R
K
P
U
B
L
I
C
A
T
I
O
N
S

40 ve 41. sorularda verilen işlemlerde her harf sıfırdan ve birbirinden farklı birer rakamı göstermektedir. Buna göre, soru işareti ile belirtilen harf ya da işlemin değerini bulunuz.

In the operations which are given in questions 40 and 41 each letter stands for a different non-zero numeral. Accordingly, find the value of the letter or operation indicated by the questions mark.

40.
$$\begin{array}{r} K L L \\ + K L \\ \hline L K K \end{array} \Rightarrow K \cdot L = ?$$

- A) 48 B) 54 C) 56 D) 63 E) 72

41.
$$\begin{array}{r} K M K \\ - L K L \\ \hline 2 4 M \end{array} \Rightarrow L = ?$$

- A) 6 B) 5 C) 4 D) 3 E) 2

42. I. $14 * 27 = 4$
II. $25 * 32 = 35$
III. $15 * 23 = 24$
IV. $42 * 51 = ?$

Yukarıdaki eşitliklerde * işaretinin görevi verilmiştir. Buna göre, dördüncü eşitlikteki soru işaretinin yerine aşağıdaki sayılardan hangisi gelmelidir?

In the equations above, the function of * is given. Accordingly, which of the following numbers does the question mark stand for in the fourth equation?

- A) 27 B) 28 C) 29 D) 30 E) 31

K
U
A
R
K
Y
A
Y
I
N
L
A
R
I

K
U
A
R
K
P
U
B
L
I
C
A
T
I
O
N
S

43. I. $\frac{3 \cdot (a \Delta b)}{4} + 12 = \frac{2 \cdot (b \Delta a)}{3} + 25$
II. $9 \cdot (5 \Delta 6) - 8 \cdot (6 \Delta 5) = ?$

Yukarıdaki birinci eşitlikte Δ işaretinin görevi verilmiştir. Buna göre, ikinci eşitlikteki soru işaretinin yerine aşağıdaki sayılardan hangisi gelmelidir?

In the first equation above, the function of Δ is given. Accordingly, which of the following numbers does the question mark stand for in the second equation?

- A) 150 B) 152 C) 154 D) 156 E) 158

44. I. $4 \square (7 \blacktriangle 2) = 36$

II. $(6 \square 3) \blacktriangle 2 = 20$

III. $(8 \blacktriangle 4) \square (5 \blacktriangle 7) = ?$

Yukarıdaki ilk iki eşitlikte \square ve \blacktriangle işaretlerinin görevleri verilmiştir. Buna göre, üçüncü eşitlikteki soru işaretinin yerine aşağıdaki sayılardan hangisi gelmelidir?

In the equations above, the functions of \square and \blacktriangle are given. Accordingly, which of the following numbers does

the question mark stand for in the third equation?

- A) 24 B) 45 C) 54 D) 67 E) 144

45. I. $a \bullet b = 4a - b$

II. $a \blacksquare b = 2a + b^2$

III. $a \blacktriangle b = a \cdot b$

IV. $(3 \bullet 5) \blacktriangle (4 \blacksquare 2) = ?$

Yukarıdaki eşitliklerde \bullet , \blacksquare ve \blacktriangle işaretlerinin görevleri verilmiştir. Buna göre, dördüncü eşitlikteki soru işaretinin yerine aşağıdaki sayılardan hangisi gelmelidir?

In the equations above, the functions of \bullet , \blacksquare and \blacktriangle are given. Accordingly, which of the following numbers does the question mark stand for in the fourth equation?

- A) 80 B) 81 C) 82 D) 83 E) 84

46.

+	a	b	c
a		15	
b			a-b
c	b+15		

$\Rightarrow a = ?$

Yukarıdaki toplama tablosunda a, b ve c harfleri pozitif birer tam sayının yerine kullanılmıştır. Buna göre, a kaçtır?

In the summation table above, the letters a, b and c each stands for a positive integer. Accordingly, what is the value of a?

- A) 3 B) 6 C) 9 D) 12 E) 15

47.

x	a	b	c
a		48	
b			96
c	72		

$\Rightarrow a = ?$

Yukarıdaki çarpma tablosunda a, b ve c harfleri pozitif birer tam sayının yerine kullanılmıştır. Buna göre, a kaçtır?

In the multiplication table above, the letters a, b and c each stands for a positive number. Accordingly, what is the value of a?

- A) 24 B) 16 C) 12 D) 8 E) 6

K
U
A
R
K
Y
A
Y
I
N
L
A
R
IK
U
A
R
K
P
U
B
L
I
C
A
T
I
O
N
S

48.

+	a	b	c
a		c-a	2·b
b			

x	a	b	c
a		75	
b			

$$\Rightarrow c = ?$$

Yukarıdaki toplama ve çarpma tablolarında a, b ve c harfleri pozitif birer tam sayının yerine kullanılmıştır. Buna göre, c kaçtır?

In the summation and multiplication tables above, the letters a, b and c each stands for a positive number.

Accordingly, what is the value of c ?

- A) 30 B) 25 C) 15 D) 10 E) 5

K
U
A
R
K
Y
A
Y
I
N
L
A
R
I

50 ve 51. soruları aşağıdaki şekle göre cevaplayınız.

Answer questions 50 and 51 in accordance with the figure given below.

Her soru birbirinden bağımsız olarak cevaplanacaktır.

Each question is to be answered independently.

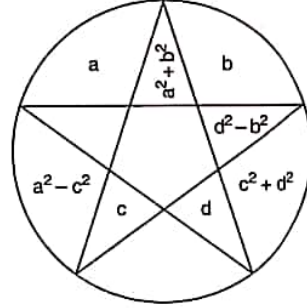

Yukarıdaki şekil a, b, c ve d harfleriyle gösterilen dört pozitif tam sayıyı içeren bazı işlemlere göre düzenlenmiştir. Harflerin gösterdiği sayılar her soruda farklı olabilir; fakat yapılacak işlemler her soruda aynıdır.

The figure above has been organized according to various operations using four positive integers represented by the letters a, b, c and d. The integers represented by the letters may change from question to question, but the operations to be done remain the same.

49.

+	a	b	c
a			
b			12

x	a	b	c
a			3·b
b	12·c		

$$\Rightarrow c = ?$$

Yukarıdaki toplama ve çarpma tablolarında a, b ve c harfleri pozitif birer tam sayının yerine kullanılmıştır. Buna göre, c kaçtır?

In the summation and multiplication tables above, the letters a, b and c each stands for a positive number.

Accordingly, what is the value of c ?

- A) 4 B) 6 C) 8 D) 12 E) 16

K
U
A
R
K
P
U
B
L
I
C
A
T
I
O
N
S

50.

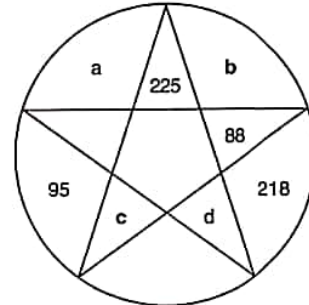

$$\Rightarrow c^2 + b^2 = ?$$

- A) 130 B) 193 C) 218 D) 225 E) 260

51.

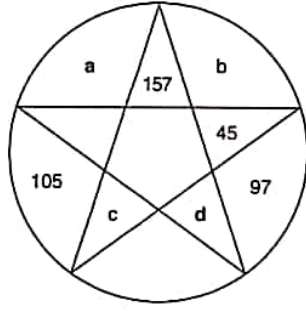

$$\Rightarrow a^2 + d^2 = ?$$

- A) 104 B) 200 C) 202 D) 408 E) 404

52.

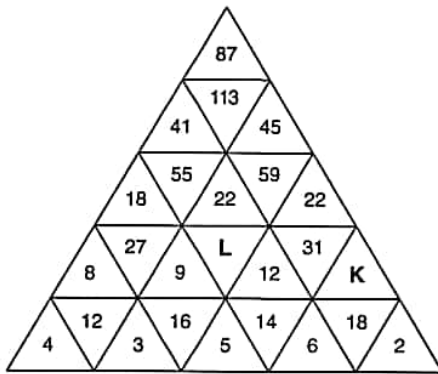

$$\Rightarrow K + L = ?$$

Yukarıdaki sayı-şekil dizisine göre $K + L$ kaçtır?
According to the number-figure sequence above, what is the value of $K + L$?

- A) 37 B) 38 C) 39 D) 40 E) 41

53.

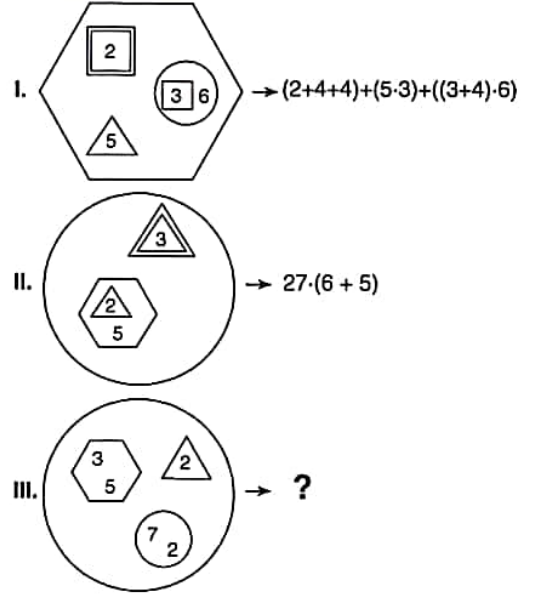

I. ve II. satırlarda belirlenen ilişkiye göre, III. satırı aşağıdaki sayılardan hangisi tamamlar?

Which of the following numbers completes III, in accordance with the relation established in I and II?

- A) 318 B) 432 C) 536 D) 672 E) 810

54.

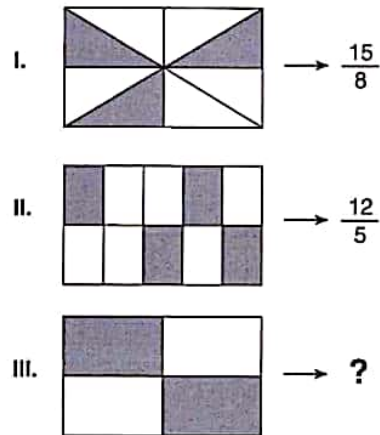

I. ve II. satırlarda belirlenen ilişkiye göre, III. satırı aşağıdaki sayılardan hangisi tamamlar?

Which of the following numbers completes III, in accordance with the relation established in I and II?

- A) 4 B) 2 C) 1 D) $\frac{1}{2}$ E) $\frac{1}{4}$

K U A R K Y A Y I N L A R I

K U A R K P U B L I C A T I O N S

55.

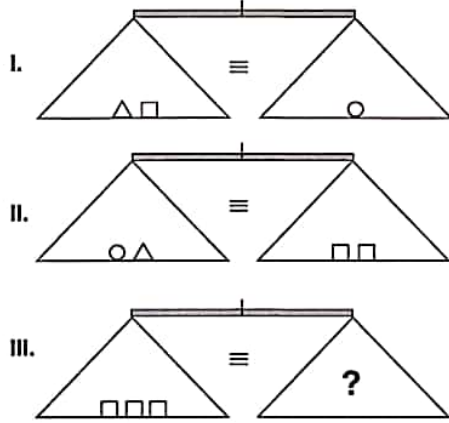

Yukarıdaki terazilerin üçü de dengededir. Buna göre, III. terazideki soru işaretini aşağıdakilerden hangisi göstermektedir?

All three scales above are in balance. Accordingly, which of the following does the question mark stand for in the third scale?

- A) \triangle B) \circ C) $\triangle\circ$
D) $\circ\circ$ E) $\triangle\triangle$

56.

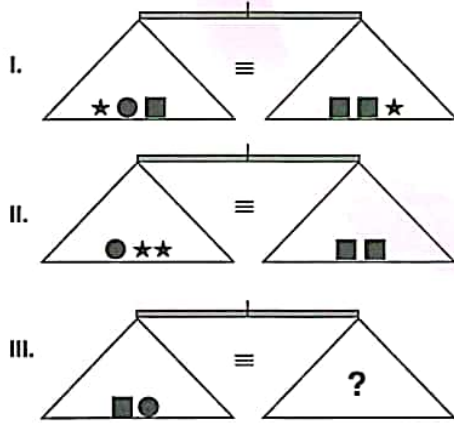

Yukarıdaki terazilerin üçü de dengededir. Buna göre, III. terazideki soru işaretini aşağıdakilerden hangisi göstermektedir?

All three scales above are in balance. Accordingly, which of the following does the question mark stand for in the third scale?

- A) $\star\star\star\star\star$ B) $\star\star\star\star$ C) $\star\star\star$
D) $\star\star$ E) \star

57.

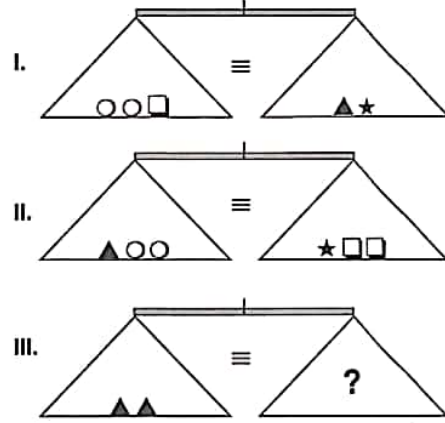

Yukarıdaki terazilerin üçü de dengededir. Buna göre, III. terazideki soru işaretini aşağıdakilerden hangisi göstermektedir?

All three scales above are in balance. Accordingly, which of the following does the question mark stand for in the third scale?

- A) $\square\triangle$ B) $\triangle\circ$ C) $\square\square\square$
D) $\circ\circ\circ$ E) $\triangle\triangle\triangle$

K U A R K Y A Y I N L A R I

K U A R K P U B L I C A T I O N S

58.

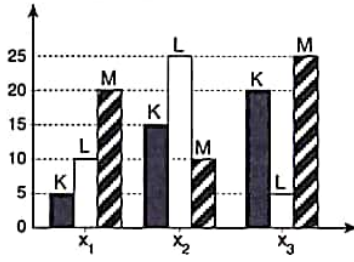

$$\Rightarrow x_1M + x_2L - x_3K = ?$$

Yukarıdaki sütun grafikte verilen bilgilere göre, $x_1M + x_2L - x_3K$ kaçtır?

According to the information in the column chart above, what is the value of $x_1M + x_2L - x_3K$?

- A) 15 B) 20 C) 25 D) 30 E) 35

59.

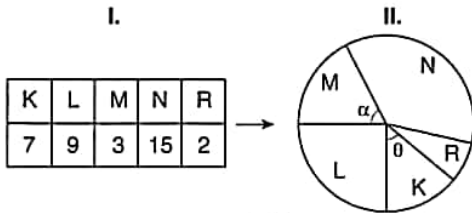

$$\Rightarrow \alpha + \theta = ?$$

II. satırda verilen dairesel grafik, I. şekilde tabloya göre düzenlenmiştir. Buna göre $\alpha + \theta$ kaçtır?

The circular chart in figure II is organised according to the table in figure I. Accordingly, what is the value of $\alpha + \theta$?

- A) 70 B) 80 C) 90 D) 100 E) 110

60, 61 ve 62. sorularda, verilen her bir şekil matrisindeki soru işaretinin yerine hangi şeklin getirilmesi gerektiğini bulunuz.

In questions 60, 61 and 62 find the figure which should replace the question mark in each given figure matrix.

60.

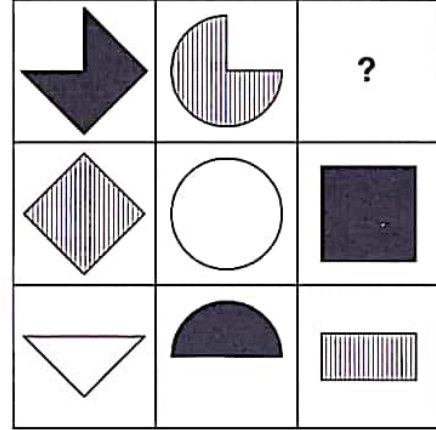

- A) B) C) D) E)

61.

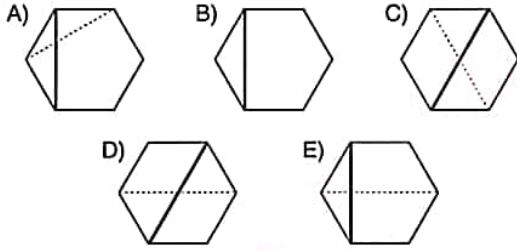
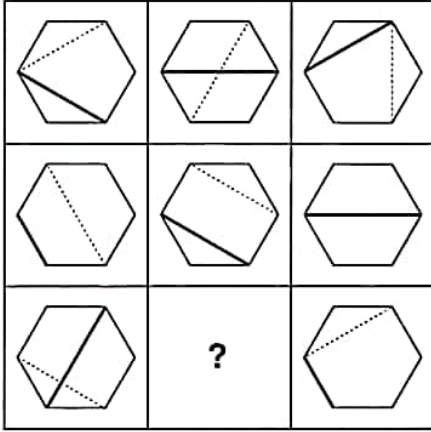

62.

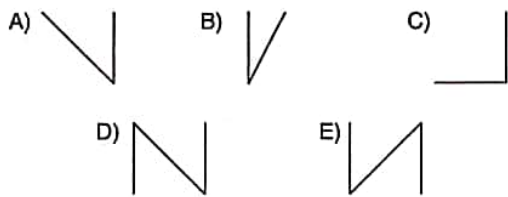
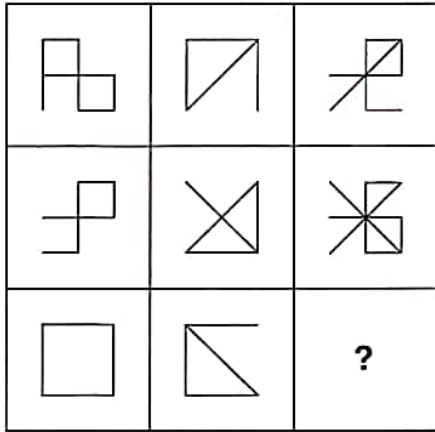

63, 64 ve 65. sorularda, I. satırda belirlenen ilişkiye göre II. satır hangi şeklin tamamladığını bulunuz.

In questions 63, 64 and 65 find the figure which completes row II, in accordance with the relation established in row I.

63.

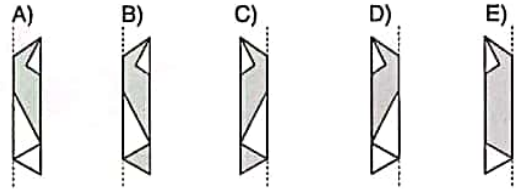
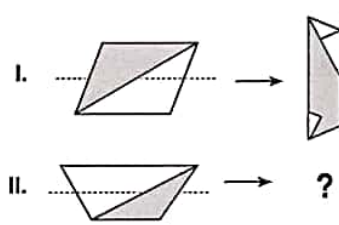

64.

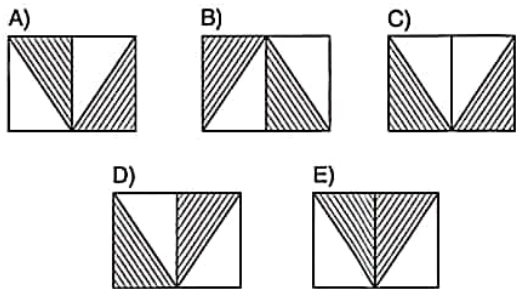
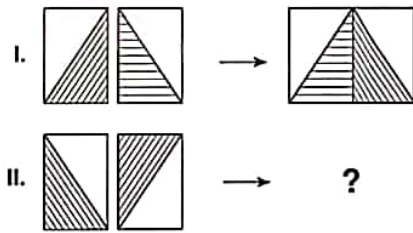

K U A R K Y A Y I N L A R I

K U A R K P U B L I C A T I O N S

65.

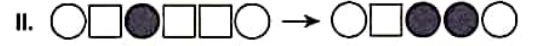
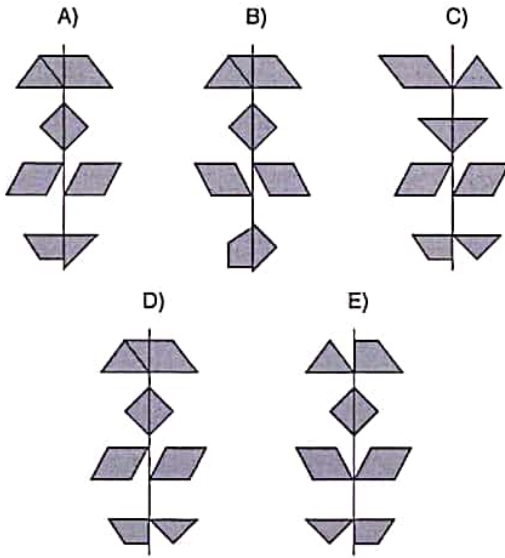
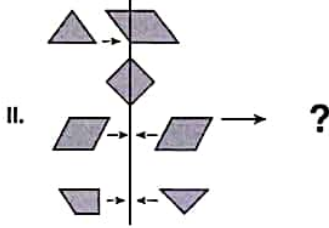
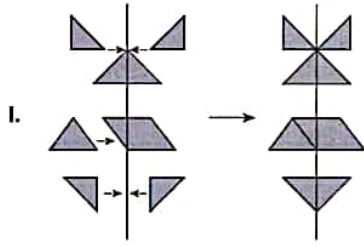

I. ve II. satırda belirlenen ilişkiye göre III. satırı hangi şeklin tamamladığını bulunuz.

Find the figure which completes row III in accordance with the relation established in rows I and II.

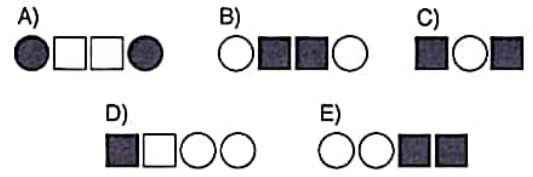

Genel Yetenek / IQ

11

67, 68 ve 69. sorularda, verilen her bir şekil dizisindeki soru işaretinin yerine hangi şeklin getirilmesi gerektiğini bulunuz.

In questions 67, 68 and 69 find the figure which should replace the question mark in each given figure sequence.

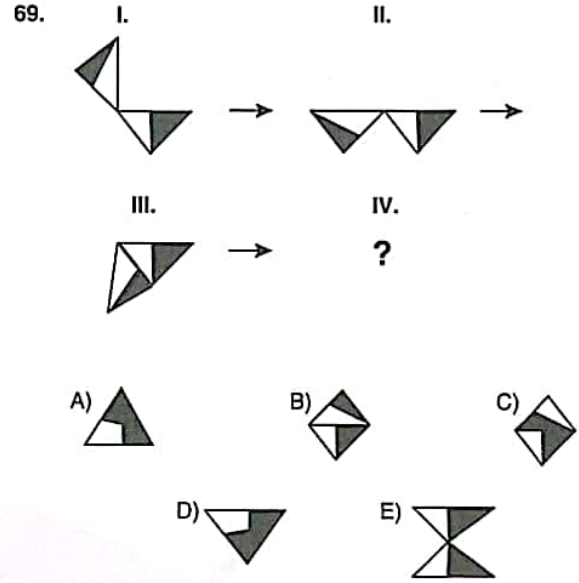
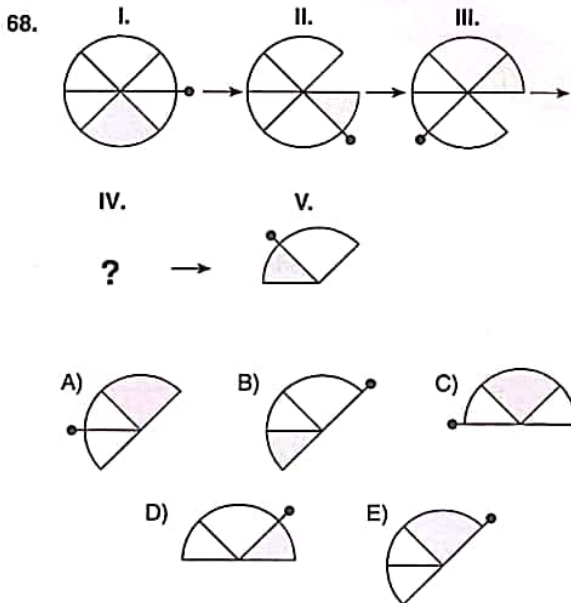
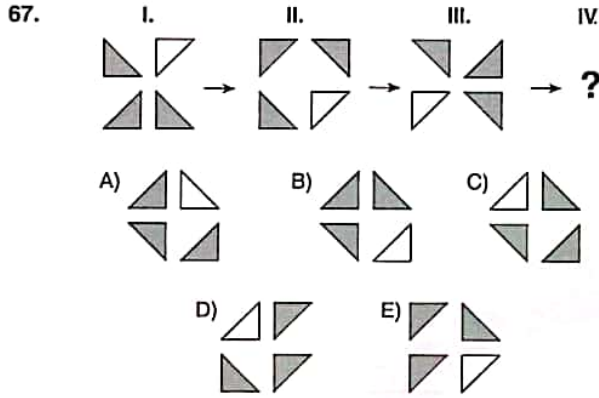

70 ve 71. sorularda, soru işaretinin yerine getirilmesi gereken şekli bulunuz.

In question 70 and 71, find the figure to replace the question mark.

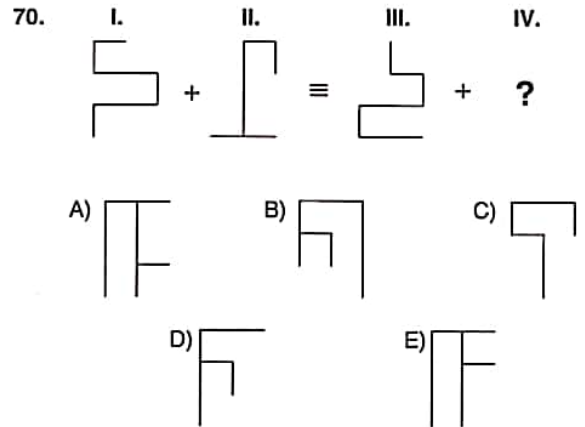

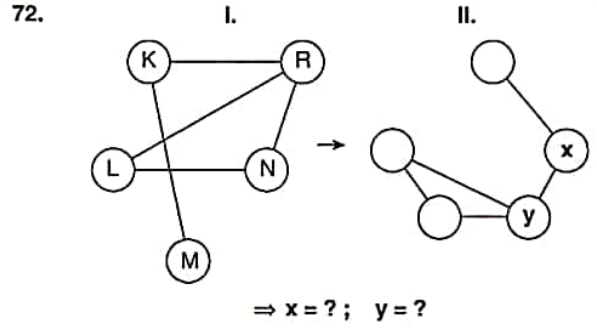
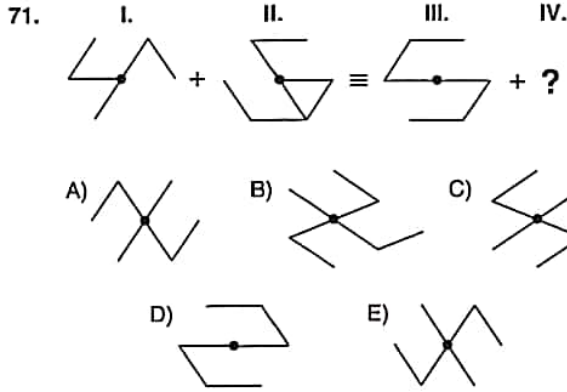

II. şekilde x ve y'nin yerine gelmesi gereken harfleri bulunuz.

Find the letters that correspond to x and y in figure II.

	x	y
A)	K	R
B)	L	R
C)	N	M
D)	N	R
E)	K	L

72 ve 73. soruları aşağıdaki örnekte verilen ilişkiye göre cevaplayınız.

Answer questions 72 and 73, in accordance with the relation established in the example below.

ÖRNEK / EXAMPLE:

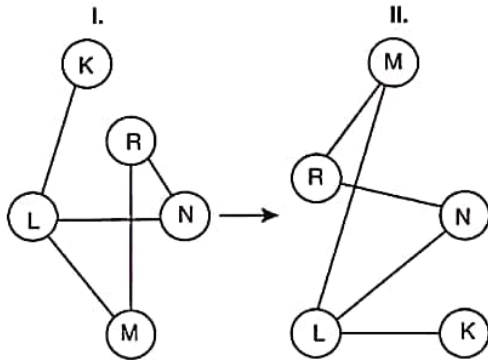

K, L, M, N ve R harfleri I. şekildeki gibi birbirine bağlanmıştır. I. şekildeki bağlantı sayıları ve birbirine bağlanan harfler değişmemek koşuluyla II. şekil elde edilmiştir.

The letters K, L, M, N and R are linked as in Figure I. Figure II has been constructed so as not to change the number of links and the letters that are linked to each other in Figure I.

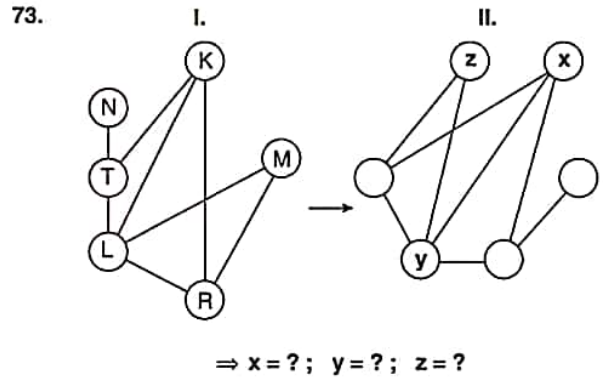

II. şekilde x, y ve z'nin yerine gelmesi gereken harfleri bulunuz.

Find the letters that correspond to x, y and z in figure II.

	x	y	z
A)	K	M	L
B)	L	M	K
C)	M	L	K
D)	K	L	M
E)	L	K	M

Genel Yetenek / IQ

11

74. Aşağıdaki şekillerden hangisi bir özelliğine göre diğerlerinden farklıdır?

Which of the following figures is different than the others according to a certain property?

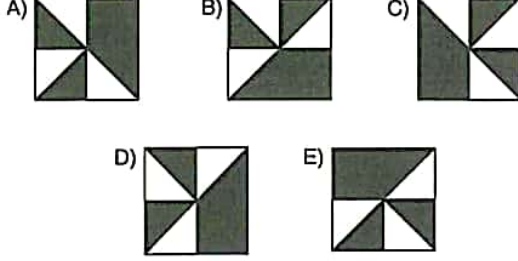

75. soruyu aşağıdaki örnekte verilen ilişkiye göre cevaplayınız.

Answer question 75, in accordance with the relation established in the example below.

ÖRNEK / EXAMPLE:

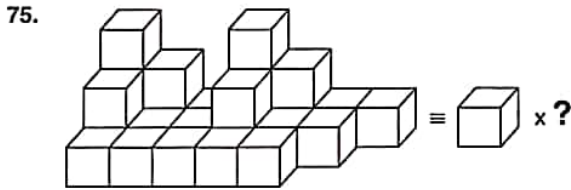
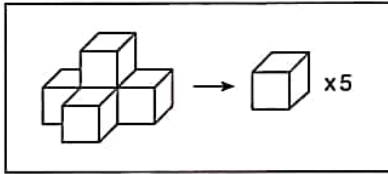

- A) 25 B) 26 C) 27 D) 28 E) 29

76 ve 77. soruları aşağıdaki örnekte verilen ilişkiye göre cevaplayınız.

Answer questions 76 and 77, in accordance with the relation established in the example below.

ÖRNEK / EXAMPLE:

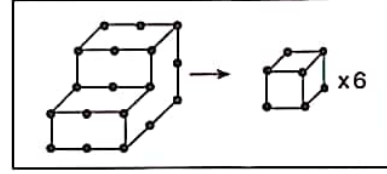

76.

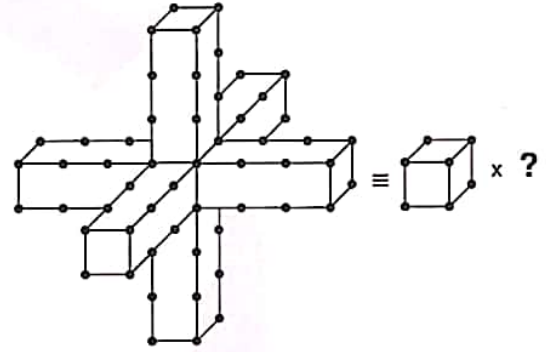

- A) 15 B) 18 C) 19 D) 24 E) 25

77.

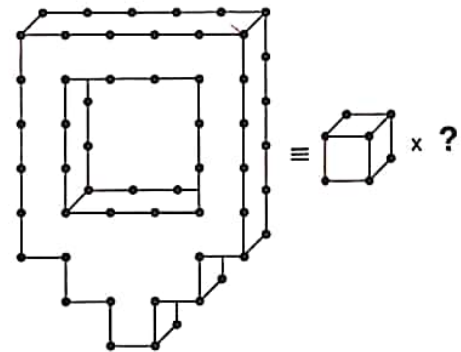

- A) 17 B) 18 C) 19 D) 20 E) 21

78.

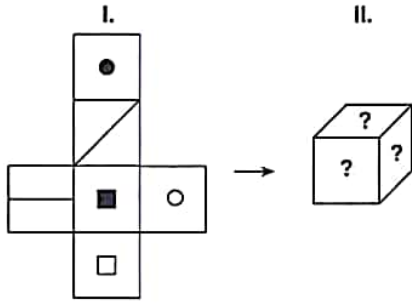

Aşağıdakilerden hangisi yukarıdaki küpün kapalı halidir?

Which of the following figure corresponds the closed form of the cube above?

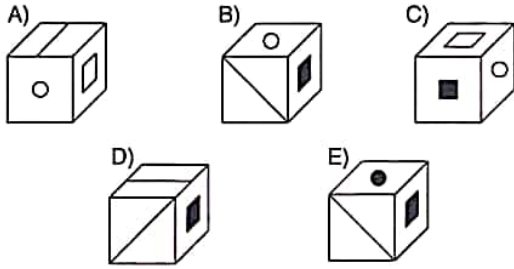

79.

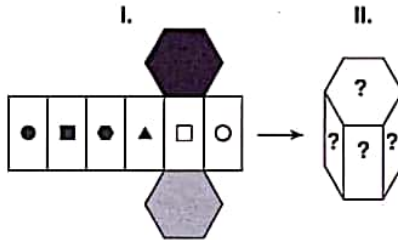

Aşağıdakilerden hangisi I. şekildeki cismin kapalı halidir?

Which of the following corresponds to the folded form of the object in figure I above?

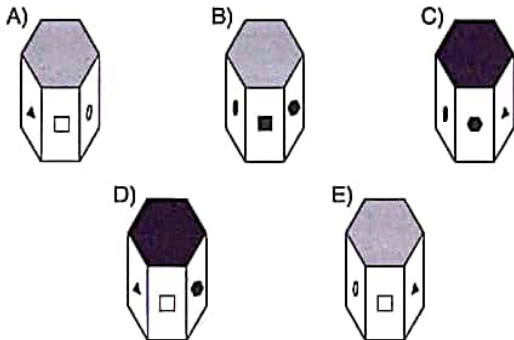

80.

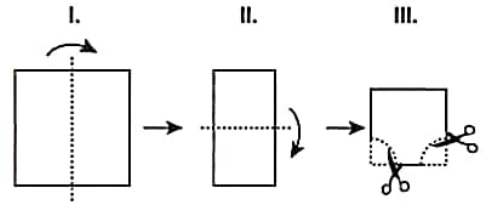

Yukarıdaki I. satırda verilen şekil, belirtilen eksenlerden adım adım katlanarak III. satırdaki şekil elde ediliyor ve ardından işaretli bölgelerden kesiliyor. Buna göre, III. satırdaki şekilde kesilen parçalar çıkartıldıktan sonra, şeklin konumu değiştirilmeden katlandığı eksenlerden açık hale getirilirse aşağıdaki şekillerden hangisi oluşur?

Figure III is formed by folding figure I step by step by the following axis and then cut by the marked areas. Accordingly, which of the following is formed when the pieces cut in figure III are thrown and figure unfolded by the folded axis remaining their position?

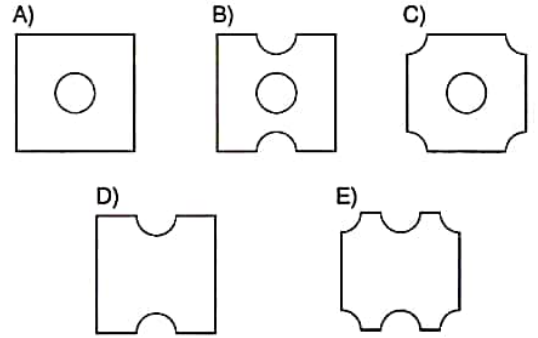

K U A R K Y A Y I N L A R I

K U A R K P U B L I C A T I O N S

1, 2, 3 ve 4. sorularda I. gruptaki her bir harf, rakam veya şekil, II. gruptaki farklı birer harf, rakam veya şekil ile gösterilmiştir.

Buna göre, soru işaretiyle belirtilen harfleri, rakamları veya şekilleri bulunuz.

In questions 1, 2, 3 and 4 each letter, numeral or figure in group I stand for a different letter, numeral or figure in group II.

Accordingly, find the letters, numerals or figures which the questions mark stands for.

1.

I.	II.
2 9 8 7	T B U C
7 2 8 9	T B C U
8 2 7 9	C B T U
8 7 9 2	B U T C
8 2 9 7	T C U B

⇒ 8792 = ?

- A) TBUC B) TBCU C) CBTU
D) BUTC E) TCUB

2.

I.	II.
H A F E	2 3 1 3
G A F A	5 4 6 7
İ G A H	5 3 1 4
F A J İ	7 2 3 5
H E J İ	1 3 6 7

⇒ HEJİ = ?

- A) 2313 B) 5467 C) 5314
D) 7235 E) 1367

3.

I.	II.
▲ + ○ × □ ✓	T E S İ Z M
☺ ○ → × ★ +	K A L M E N
■ □ △ ↓ ← ×	Z U E İ M A
× + ● ☺ ✓ △	U L İ M R A
← ☺ □ → × +	M A Y U N S

⇒ ■ □ △ ↓ ← × = ?

- A) TESİZM B) KALMEN C) ZUEİMA
D) ULİMRA E) MAYUNS

4.

I.	II.
B A K İ	7 1 4 6
İ K A T	4 3 5 9
M İ B A	1 5 6 3
A B L M	3 4 1 7
K L T B	9 7 3 4

⇒ BAKİ = ?

- A) 7146 B) 4359 C) 1563
D) 3417 E) 9734

5 ve 6. sorulardaki verilen işlemlerde her harf sıfırdan ve birbirinden farklı birer rakamı göstermektedir.

Buna göre, soru işareti ile belirtilen harf ya da işlemin değerini bulunuz.

In the operations which are given in questions 5 and 6, each letter stands for a different non-zero numeral. Accordingly, find the value of the letter or operation indicated by the questions mark.

$$5. \quad \begin{array}{r} \text{K N M} \\ + \text{LN} \\ \hline \text{M 5 K} \end{array} \Rightarrow L = ?$$

- A) 2 B) 3 C) 4 D) 5 E) 6

$$6. \quad \begin{array}{r} \text{K L M} \\ - \text{M L K} \\ \hline \text{P R T} \end{array} \Rightarrow P + T + R = ?$$

- A) 16 B) 17 C) 18 D) 19 E) 20

7. I. $27 \square 6 = 3$
II. $18 \square 13 = 5$
III. $68 \square 33 = 8$
IV. $75 \square 15 = ?$

Yukarıdaki eşitliklerde \square işaretinin görevi verilmiştir. Buna göre, dördüncü eşitlikteki soru işaretinin yerine aşağıdaki sayılardan hangisi gelmelidir?

In the equations above, the function of \square is given. Accordingly, which of the following numbers does the question mark stand for in the fourth equation?

- A) 2 B) 3 C) 4 D) 5 E) 6

8. I. $a \blacktriangle \frac{b}{2} = a - b$
II. $3 \cdot a \star b = (a + b)$
III. $(12 \blacktriangle 4) \star (12 \star 5) = ?$

Yukarıdaki eşitliklerde \blacktriangle ve \star işaretlerinin görevleri verilmiştir. Buna göre, üçüncü eşitlikteki soru işaretinin yerine aşağıdaki sayılardan hangisi gelmelidir?

In the equations above, the functions of \blacktriangle and \star are given. Accordingly, which of the following numbers does the question mark stand for in the third equation?

- A) 25 B) 36 C) 41 D) 53 E) 68

K
U
A
R
K
Y
A
Y
I
N
L
A
R
IK
U
A
R
K
P
U
B
L
I
C
A
T
I
O
N
S

YÖS

12

9. I. $(a, b) \square (c, d) = (a^{-1}, b^{-2}) \Delta (c^{-2}, d^{-1})$
 II. $(a, b) \Delta (c, d) = (\sqrt{a} \cdot \sqrt[4]{b}, \sqrt{a} \cdot \sqrt[3]{d})$
 III. $(4, 9) \square (4, 27) = ?$

Yukarıdaki eşitliklerde \square ve Δ işaretlerinin görevleri verilmiştir. Buna göre, üçüncü eşitlikteki soru işaretinin yerine aşağıdaki sayılardan hangisi gelmelidir?

In the equations above, the functions of \square and Δ are given. Accordingly, which of the following numbers does the question mark stand for in the third equation?

- A) $(\frac{1}{6}, \frac{1}{6})$ B) $(\frac{1}{3}, \frac{1}{9})$ C) $(\frac{1}{9}, \frac{1}{12})$
 D) $(\frac{1}{6}, \frac{1}{12})$ E) $(\frac{1}{9}, \frac{1}{6})$

10. I. $\frac{(a \Delta b) - b}{a} = \frac{(a \Delta b) + a}{b}$
 II. $(4 \Delta 5) = ?$

Yukarıdaki ilk eşitlikte Δ işaretinin görevi verilmiştir. Buna göre, ikinci eşitlikteki soru işaretinin yerine aşağıdaki sayılardan hangisi gelmelidir?

In the first equation above, the function of Δ is given. Accordingly, which of the following numbers does the question mark stand for in the second equation?

- A) 9 B) 23 C) 34 D) 41 E) 48

11. 1 2 6 24 120 ? 5040

Yukarıda verilen sayı dizisinde soru işaretinin yerine getirilmesi gereken sayıyı bulunuz.

Find the number which the question mark stands for in the given number sequence above.

- A) 720 B) 840 C) 960
 D) 1080 E) 1200

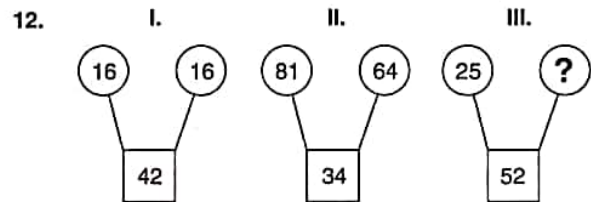
K
U
A
R
K
Y
A
Y
I
N
L
A
R
IK
U
A
R
K
P
U
B
L
I
C
A
T
I
O
N
S

I. ve II. şekillerde verilen kurala göre, III. şekildeki soru işaretinin yerine aşağıdaki sayılardan hangisi gelmelidir?

Which of the following numbers does the question mark stand for in figure III, in accordance with the rule established in figures I and II?

- A) 20 B) 28 C) 32 D) 36 E) 49

13.

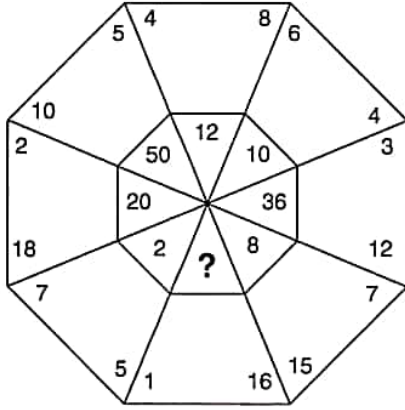

Yukarıdaki sayı-şekil ilişkisine göre soru işaretinin yerine aşağıdaki sayılardan hangisi gelmelidir?

Which of the following numbers does the question mark stand for, according to the number-figure relation above?

- A) 4 B) 8 C) 12 D) 16 E) 24

14.

+	a	b	c
a		c+4	
b		a+c	a
c			

$$\Rightarrow a + b + c = ?$$

Yukarıdaki toplama tablosunda a, b ve c harfleri pozitif birer tamsayının yerine kullanılmıştır. Buna göre, $a + b + c$ kaçtır?

In the summation table above, the letters a, b and c each stands for a positive integer. Accordingly, what is the value of $a + b + c$?

- A) 4 B) 5 C) 6 D) 7 E) 8

15.

x	a	b	c
a		$2 \cdot a^2$	
b			$14a$
c	28		

$$\Rightarrow b + c = ?$$

Yukarıdaki çarpma tablosunda a, b ve c harfleri pozitif birer tamsayının yerine kullanılmıştır. Buna göre, $b + c$ kaçtır?

In the multiplication table above, the letters a, b and c each stand for a positive integer. Accordingly, what is the value of $b + c$?

- A) 10 B) 15 C) 20 D) 25 E) 30

16.

+	a	b	c
a			
b			8

x	a	b	c
a			
b		a	$3 \cdot c$

$$\Rightarrow a = ?$$

Yukarıdaki toplama ve çarpma tablolarında a, b ve c harfleri pozitif birer tamsayının yerine kullanılmıştır. Buna göre, a kaçtır?

In the summation and multiplication tables above, the letters a, b and c each stands for a positive integer. Accordingly, what is the value of a?

- A) 9 B) 10 C) 11 D) 12 E) 13

17, 18 ve 19. soruları aşağıdaki şekile göre cevaplayınız.

Answer questions 17, 18 and 19 in accordance with the figure given below.

Her soru birbirinden bağımsız olarak cevaplanacaktır.

Each question is to be answered independently.

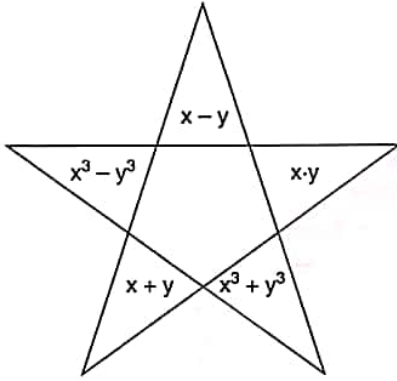

Yukarıdaki şekil x ve y harfleriyle gösterilen birbirinden farklı iki tam sayıyı içeren bazı işlemlere göre düzenlenmiştir. Harflerin gösterdiği sayılar her soruda farklı olabilir; fakat, bunlarla yapılacak işlemler her soruda aynıdır.

The figure above has been organized according to various operations using two different integers represented by the letters, x and y. The integers represented by the letters may change from question to question, but the operations to be done remain the same.

17.

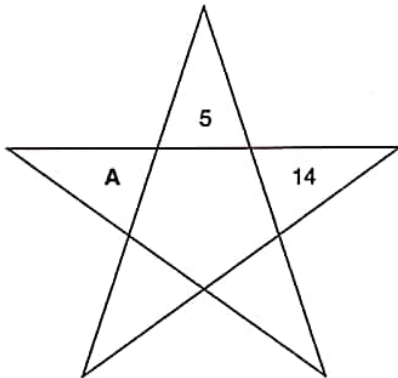

$$\Rightarrow A = ?$$

- A) 332 B) 333 C) 334 D) 335 E) 336

18.

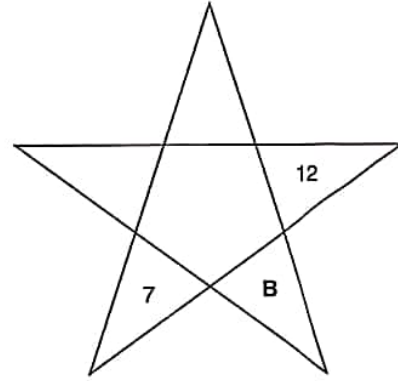

$$\Rightarrow B = ?$$

- A) 89 B) 90 C) 91 D) 92 E) 93

19.

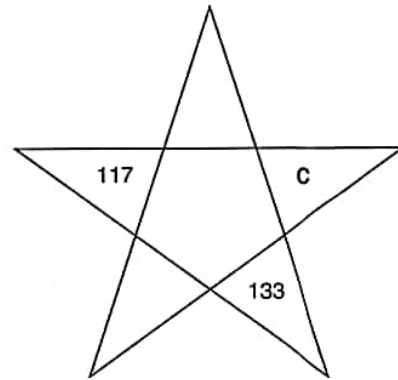

$$\Rightarrow C = ?$$

- A) 10 B) 11 C) 12 D) 13 E) 14

20.

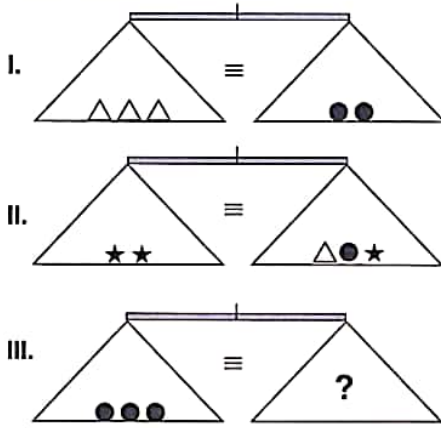

Yukarıdaki terazilerin üçü de dengede olduğuna göre, III. terazide soru işaretini aşağıdakilerden hangisi göstermektedir?

All three scales above are in balance. Accordingly, which of the following does the question mark stand for in the third scale?

- A) ★★△△ B) ★★△ C) △△★
D) △△ E) ★★

21.

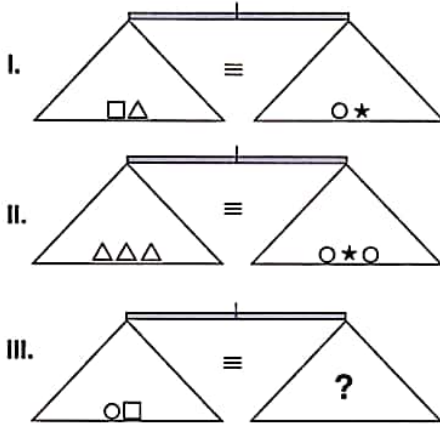

Yukarıdaki terazilerin üçü de dengede olduğuna göre, III. terazide soru işaretini aşağıdakilerden hangisi göstermektedir?

All three scales above are in balance. Accordingly, which of the following does the question mark stand for in the third scale?

- A) △ B) △△ C) △△△
D) △△△△ E) △△△△△

22.

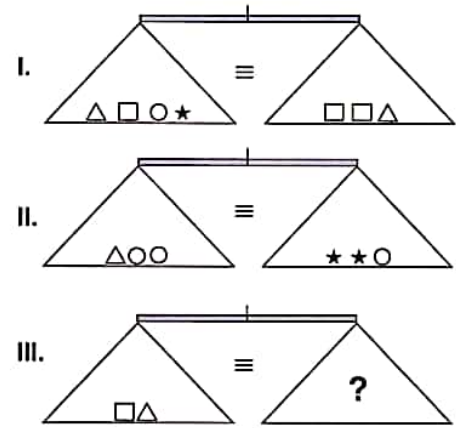

Yukarıdaki terazilerin üçü de dengede olduğuna göre, III. terazide soru işaretini aşağıdakilerden hangisi göstermektedir?

All three scales above are in balance. Accordingly, which of the following does the question mark stand for in the third scale?

- A) ○ B) ○○ C) ○★
D) ○○○ E) ★★★

K U A R K Y A Y I N L A R I

K U A R K P U B L I C A T I O N S

YÖS

12

23.

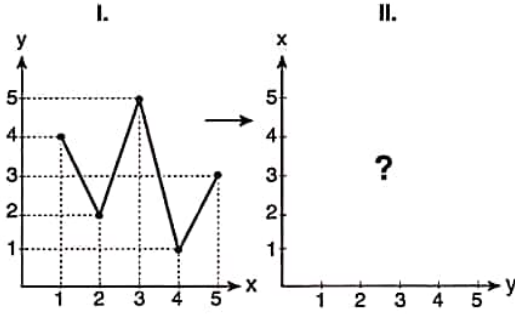

Yukarıdaki birinci çizgi grafikte verilen bilgilere göre, ikinci grafik aşağıdakilerden hangisidir?

According to the first line chart above, which of the following does the second chart stand for?

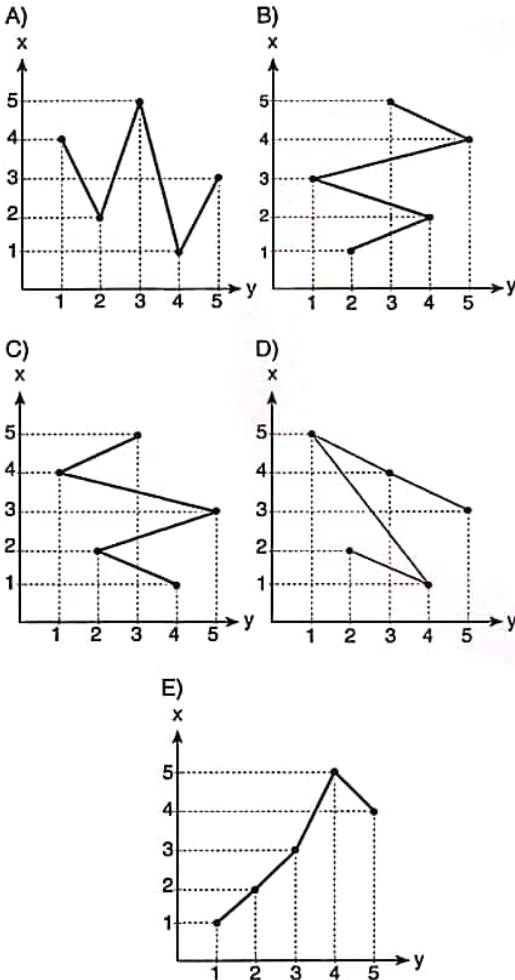

24.

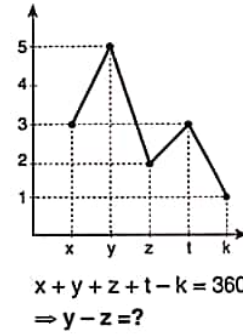

Yukarıdaki çizgi grafikte verilen bilgilere göre, $y - z$ kaçtır?

According to the information in the line chart above, what is the value of $y - z$?

- A) 40 B) 60 C) 90 D) 100 E) 120

25.

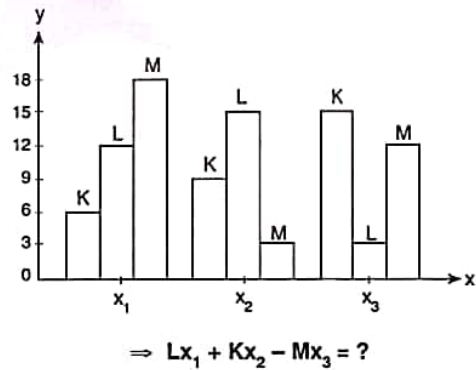

Yukarıdaki sütun grafikte verilen bilgilere göre, $Lx_1 + Kx_2 - Mx_3$ kaçtır?

According to the information in the column chart above, what is the value of $Lx_1 + Kx_2 - Mx_3$?

- A) 8 B) 9 C) 10 D) 11 E) 12

K U A R K Y A Y I N L A R I

K U A R K P U B L I C A T I O N S

YÖS

12

26.

★	○	□	▲	●	◆
○	□	▲	●	L	○
□	▲	●	◆	○	□
▲	●	K	○	N	▲
●	◆	○	□	▲	●
◆	○	M	▲	●	◆

$$\Rightarrow (K \star M) \star (N \star L) = ?$$

Yukarıdaki tabloda \star işleminin kuralı verilmiştir. Buna göre, $(K \star M) \star (N \star L)$ nedir?

The rule of \star operation is given in the table above. Accordingly, what is the value of $(K \star M) \star (N \star L)$?

- A) □ B) ● C) ▲ D) ◆ E) ▼

27.

R	M	Z	N	R
M	R	K	Z	N
N	K	M	R	N
Z	M	K	K	M
K	R	K	M	Z

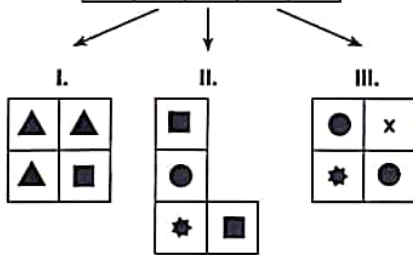

$$\Rightarrow x = ?$$

I, II ve III yukarıdaki tablonun farklı birer parçasıdır. Buna göre, x aşağıdakilerden hangisidir?

I, II and III are three different parts of the table above.

Accordingly, which of the following does x stand for?

- A) R B) M C) Z D) N E) K

28 ve 29. soruları örnekte verilen ilişkiye göre cevaplayınız.

In questions 28 and 29, find the correct answer in accordance with the relationship established in the example below.

ÖRNEK / EXAMPLE:

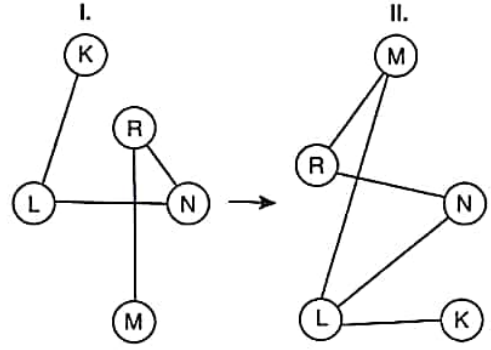

K, L, M, N ve R harfleri I. şekildeki gibi birbirine bağlanmıştır. I. şekildeki bağlantı sayıları ve birbirine bağlanan harfler değişmemek koşuluyla II. şekil elde edilmiştir.

Letters K, L, M, N ve R are linked as in figure I. Figure II has been constructed so as not to change which letters are linked to which, and the number of links made with each letter, in figure I.

28.

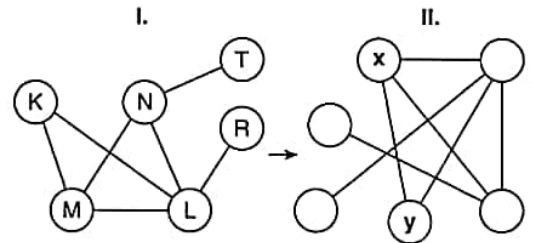

$$\Rightarrow x; y = ?$$

- A) M ; L B) N ; K C) N ; R
D) M ; K E) L ; R

YÖS

12



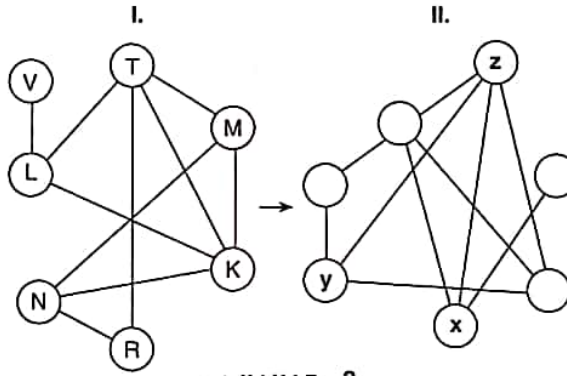

29.

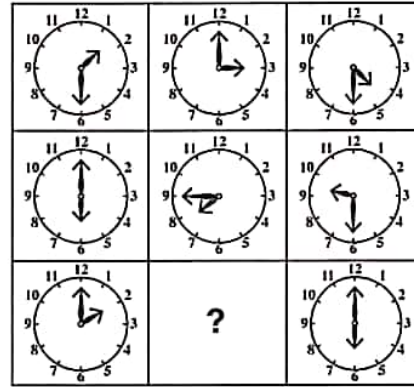

- A) L; M; K B) M; N; T C) L; N; K
D) M; L; K E) N; L; T

31.





- A) 
- B) 
- C) 
- D) 
- E) 

30, 31 ve 32. sorularda, verilen her bir şekil matrisindeki soru işaretinin yerine hangi şeklin getirilmesi gerektiğini bulunuz.

In questions 30, 31 and 32 find the figure which should replace the question mark in each given figure matrix.

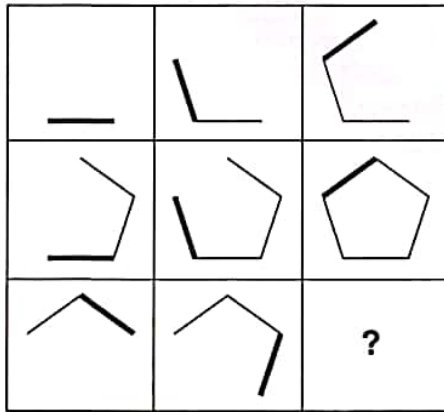
30.

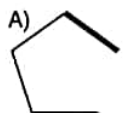
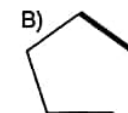

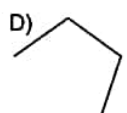
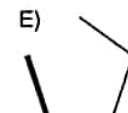
- A) 
- B) 
- C) 
- D) 
- E) 

32.

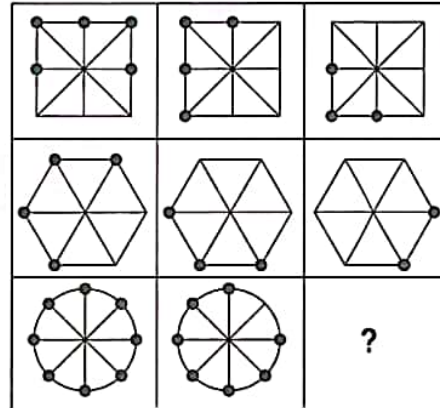

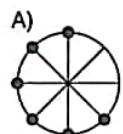
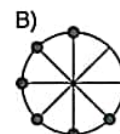
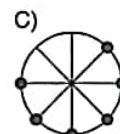
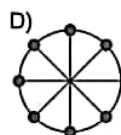
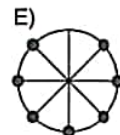
- A) 
- B) 
- C) 
- D) 
- E) 

33, 34 ve 35. sorularda, I. satırda belirlenen ilişkiye göre II. satırı hangi şeklin tamamladığını bulunuz.

In questions 33, 34 and 35 find the figure which completes row II in accordance with the relation in row I.

33.

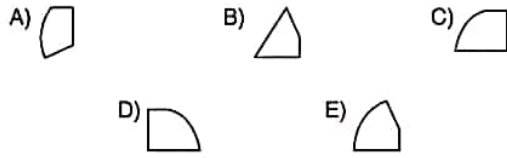
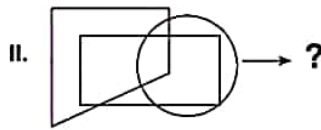
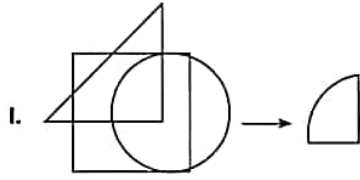

34.

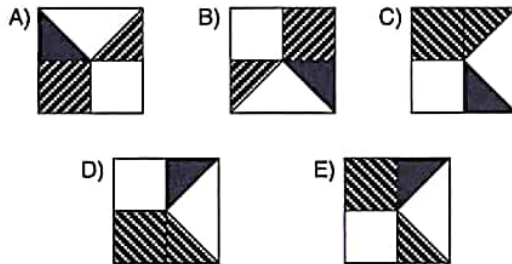
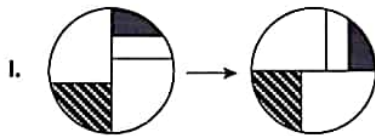

35.

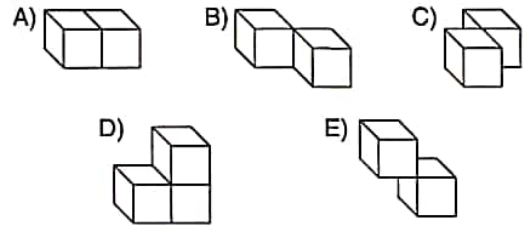
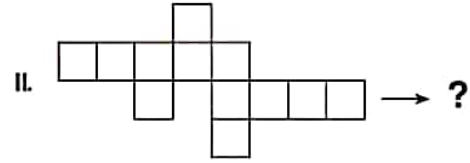
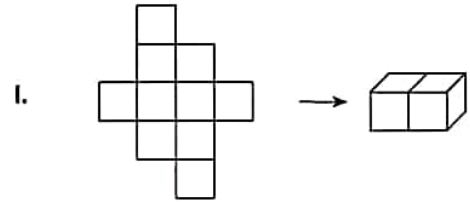

36, 37 ve 38. sorularda, verilen her şekil dizisindeki soru işaretinin yerine hangi şeklin getirilmesi gerektiğini bulunuz.

In questions 36, 37 and 38 find the figure which should replace the question mark in each given figure sequence.

36.

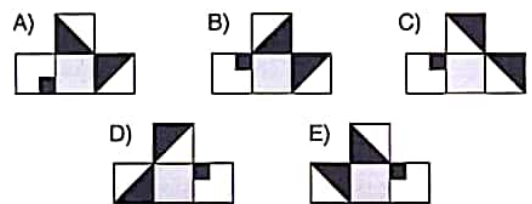
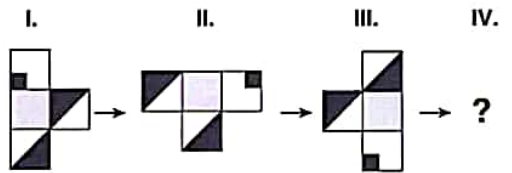

YÖS

12

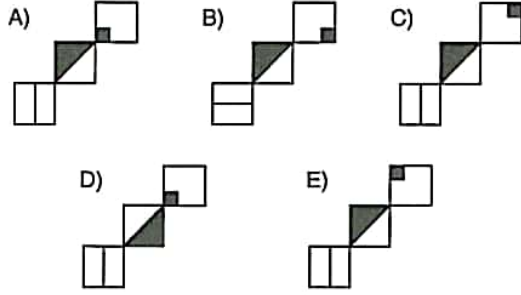
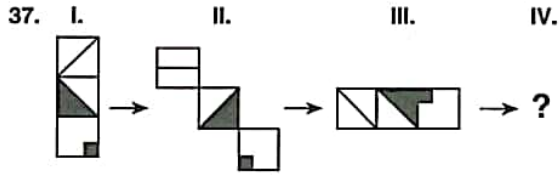

39 ve 40. sorularda, soru işaretinin yerine getirilmesi gereken şekli bulunuz.

In question 39 and 40, find the figure to replace the question mark.

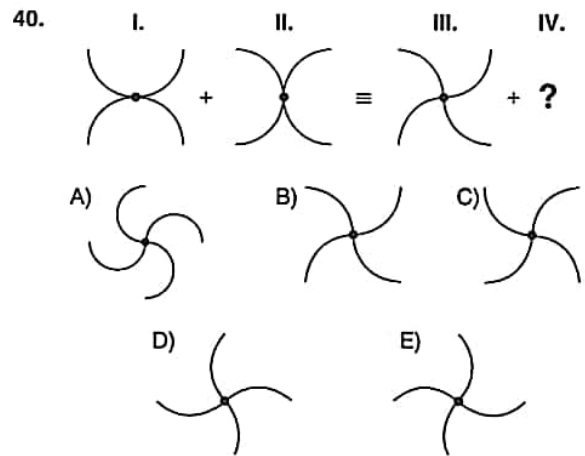
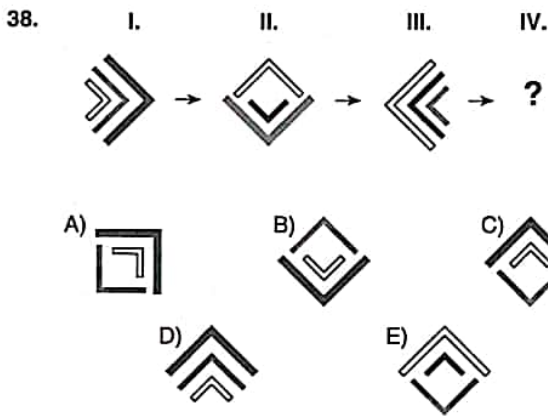
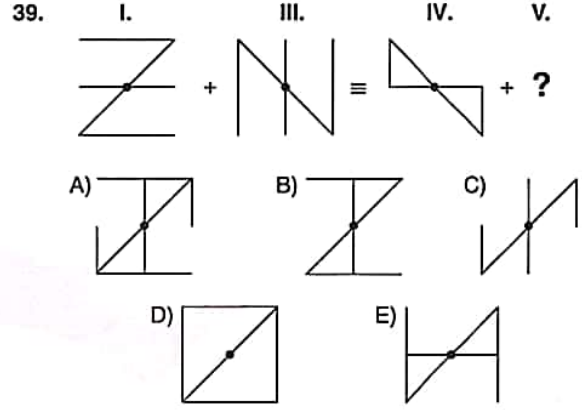

YÖS

12

41. soruyu aşağıdaki örnekte verilen ilişkiye göre cevaplayınız.

Answer question 41 in accordance with the relation established in the example below.

ÖRNEK / EXAMPLE:

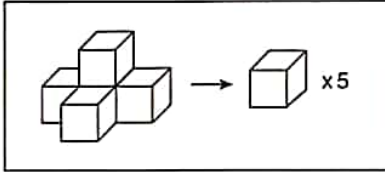

41.

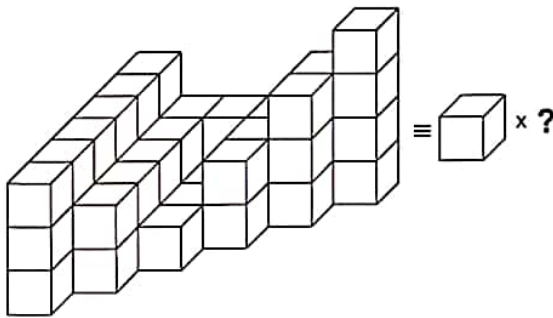

- A) 45 B) 46 C) 47 D) 48 E) 49

42 ve 43. soruları aşağıdaki örnekte verilen ilişkiye göre cevaplayınız.

Answer questions 42 and 43 in accordance with the relation established in the example below.

ÖRNEK / EXAMPLE:

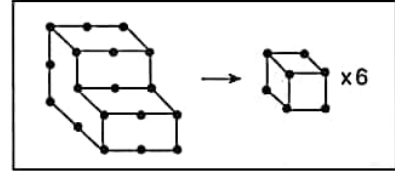

42.

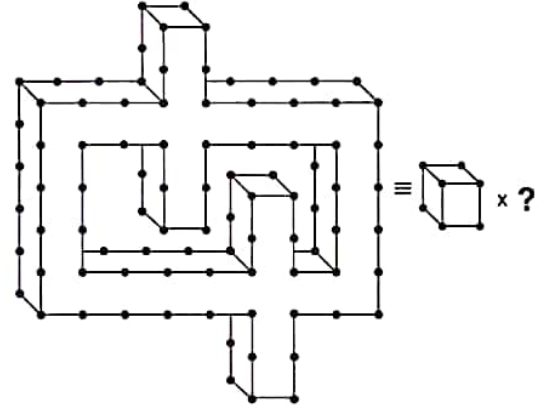

- A) 28 B) 29 C) 30 D) 31 E) 32

43.

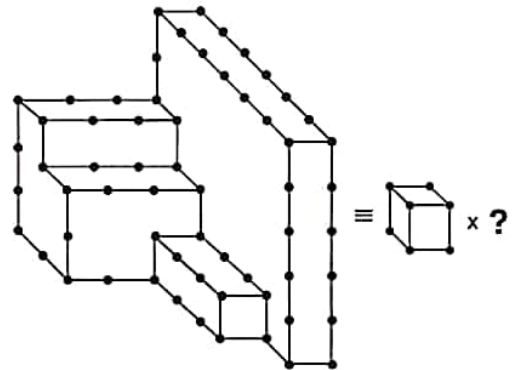

- A) 47 B) 48 C) 49 D) 50 E) 51

K U A R K Y A Y I N L A R I

K U A R K P U B L I C A T I O N S

44.

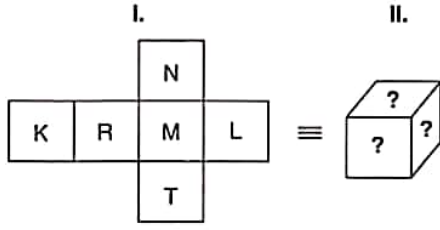

Aşağıdakilerden hangisi I. şekildeki küpün kapalı halidir?

Which of the following corresponds to the folded form of the cube in figure I above?

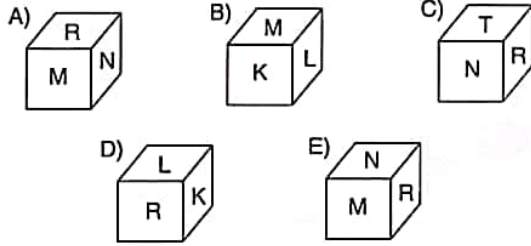

45.

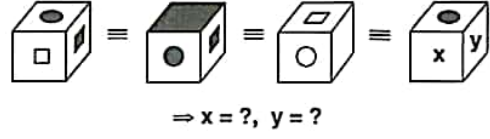

Yukarıdaki şekillerin tümü aynı nesneyi göstermektedir. Buna göre, x ve y aşağıdakilerden hangisidir? The figures above all represent the same object. Accordingly which of the following stands for x and y?

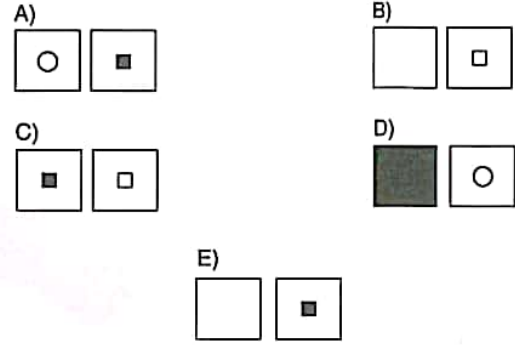

YÖS

12

46. $A < B < C$,
 $A, B, C \in \mathbb{Z}^+$

$$\frac{2A+C}{3} = B \Rightarrow \min(A+B+C) = ?$$

- A) 6 B) 7 C) 8 D) 9 E) 10

47. $(3,1)_6 + (10,2)_4 = A \Rightarrow (A)_{10} = ?$

- A) $\frac{19}{3}$ B) $\frac{23}{3}$ C) $\frac{29}{6}$ D) $\frac{37}{6}$ E) $\frac{47}{6}$

48. $x + \frac{1}{x} = 3 \Rightarrow \left| x^2 - \frac{1}{x^2} \right| = ?$

- A) $\sqrt{5}$ B) $2\sqrt{5}$ C) $3\sqrt{5}$
 D) $4\sqrt{5}$ E) $5\sqrt{5}$

49. $\frac{x^2+x-12}{x^2+3x-4} : \frac{x^2-9}{x^2+2x-3} = ?$

- A) 1 B) x C) $\frac{1}{x}$ D) -x E) $-\frac{1}{x}$

50. $\frac{0,06}{0,032} : \frac{0,24}{1,6} - \frac{9,6}{14,4} = ?$

- A) $\frac{40}{3}$ B) $\frac{48}{5}$ C) $\frac{57}{6}$ D) $\frac{64}{5}$ E) $\frac{71}{6}$

51. $x, y \in \mathbb{Z}$

$$2^{x+1} - 2^{x-1} = 3^{y+1} - 3^{y-1} \Rightarrow x \cdot y = ?$$

- A) 4 B) 6 C) 8 D) 10 E) 12

K
U
A
R
K
Y
A
Y
I
N
L
A
R
IK
U
A
R
K
P
U
B
L
I
C
A
T
I
O
N
S

YÖS

12

52. $2^x = 3,$

$9^y = 2 \Rightarrow x \cdot y = ?$

- A)
- $\frac{1}{3}$
- B)
- $\frac{1}{2}$
- C)
- $\frac{2}{3}$
- D) 1 E)
- $\frac{3}{2}$

53. $\sqrt{2} \cdot \sqrt[3]{2} \cdot \sqrt[4]{2} = 4^n \Rightarrow n = ?$

- A)
- $\frac{1}{12}$
- B)
- $\frac{1}{8}$
- C)
- $\frac{5}{12}$
- D)
- $\frac{13}{24}$
- E)
- $\frac{13}{12}$

54. $x \in \mathbb{Z}, A \in \mathbb{R},$

$\sqrt{5 - |2x - 1|} = A \Rightarrow \sum x = ?$

- A) -3 B) -2 C) 2 D) 3 E) 6

55. $x < |x|, 0 < y$

$|x - y| - |y - 3x| = -8 \Rightarrow x = ?$

- A) -6 B) -5 C) -4 D) -3 E) -2

56. $a + \frac{5}{b} = 2, b + \frac{7}{a} = 3$

$\Rightarrow \frac{2b - 3a + 2}{a + b} = ?$

- A) 3 B) 2 C) 1 D) 0 E) -1

57. $2x + y - 2z = -1$

$3x + 4y - 3z = 6$

$\Rightarrow y = ?$

- A) -3 B) -2 C) 2 D) 3 E) 5

K
U
A
R
K
Y
A
Y
I
N
L
A
R
IK
U
A
R
K
P
U
B
L
I
C
A
T
I
O
N
S

YÖS

12

58. $f: A \rightarrow A, g: A \rightarrow A,$

$$A = \{1, 2, 3\}$$

$$f = \begin{pmatrix} 1 & 2 & 3 \\ 3 & 1 & 2 \end{pmatrix}, (f \circ g^{-1}) = \begin{pmatrix} 1 & 2 & 3 \\ 2 & 3 & 1 \end{pmatrix} \Rightarrow g = ?$$

A) $\begin{pmatrix} 1 & 2 & 3 \\ 3 & 1 & 2 \end{pmatrix}$ B) $\begin{pmatrix} 1 & 2 & 3 \\ 2 & 3 & 1 \end{pmatrix}$ C) $\begin{pmatrix} 1 & 2 & 3 \\ 2 & 1 & 3 \end{pmatrix}$

D) $\begin{pmatrix} 1 & 2 & 3 \\ 3 & 2 & 1 \end{pmatrix}$ E) $\begin{pmatrix} 1 & 2 & 3 \\ 1 & 3 & 2 \end{pmatrix}$

60. $(975)^{955} \equiv x \pmod{7} \Rightarrow x = ?$

A) 1 B) 2 C) 3 D) 4 E) 5

61. $n(A) + n(B') = 7,$

$$n(A') + n(B) = 13$$

$$n(E) = x \Rightarrow \binom{x}{2} = ?$$

A) 10 B) 15 C) 30 D) 40 E) 45

59. $f\left(\frac{x+1}{2}\right) = 3x - 4,$

$$f^{-1}(3m - 4) = 2 \Rightarrow m = ?$$

A) 3 B) 4 C) 5 D) 6 E) 7

62. $\frac{P(x+3)}{Q(x-1)} = x^2 - 3$

$$\frac{Q(x)}{4} \Big| \frac{x+3}{4} \quad \frac{P(x)}{K(x)} \Big| \frac{x-1}{K(x)} \Rightarrow K(x) = ?$$

A) -2 B) -1 C) 1 D) 2 E) 4

K
U
A
R
K
Y
A
Y
I
N
L
A
R
IK
U
A
R
K
P
U
B
L
I
C
A
T
I
O
N
S

YÖS

12

63. $a \in \mathbb{Z}'$,
 $x^2 - 4x + 1 = 0$ ÇK(SS) = $\{x_1, x_2\}$
 $ax^2 + bx + c = 0$ ÇK(SS) = $\{x_1 - 1, x_2 - 1\}$
 $\Rightarrow \min(a \cdot b \cdot c) = ?$
 A) -4 B) -2 C) 0 D) 2 E) 4

64. $\log_2 3 = a \Rightarrow \log_{12} 18 = ?$
 A) $\frac{a}{a+2}$ B) $\frac{2a}{2a+1}$ C) $\frac{2a+1}{a+1}$
 D) $\frac{2a-1}{a+2}$ E) $\frac{2a+1}{a+2}$

65. $\frac{-\sqrt{3}}{\cos 10^\circ} + \frac{1}{\sin 10^\circ} = ?$
 A) $\frac{1}{2}$ B) $-\frac{1}{2}$ C) 4 D) 3 E) 5

66. $x < 90^\circ$,
 $\frac{1}{1 - \tan x} - \frac{1}{1 + \tan x} = -\sqrt{3}$
 $\Rightarrow x = ?$
 A) 15° B) 30° C) 45° D) 60° E) 75°

67. $\sum_{k=2}^{18} (2k-3) = A$
 $A - B^2 = 280 \Rightarrow B = ?$
 A) 3 B) 6 C) 9 D) 10 E) 15

68. $a_n = a_{n-1} + n$
 $a_3 = 6 \Rightarrow a_{18} = ?$
 A) 169 B) 170 C) 171 D) 172 E) 173

K
U
A
R
K
Y
A
Y
I
N
L
A
R
IK
U
A
R
K
P
U
B
L
I
C
A
T
I
O
N
S

$$69. f(x) = \begin{cases} x^2 + 2, & x < 2 \\ 4, & x = 2 \\ 2x + m, & x > 2 \end{cases}$$

$\forall x \in \mathbb{R}$ için $f(x)$ fonksiyonunun limiti var olduğuna göre, $m = ?$

If $f(x)$ has a limit for $\forall x \in \mathbb{R}$, what is the value of m ?

- A) $\frac{1}{2}$ B) 1 C) 2 D) 3 E) 4

$$70. f(x) = \frac{8x - 7}{x^2 + 4x + k}$$

$\forall x \in \mathbb{R}$ için $f(x)$ sürekli bir fonksiyon ise $k = ?$

If $f(x)$ is continuous for $\forall x \in \mathbb{R}$, what is the value of k ?

- A) $\{-2\}$ B) $(-\infty, 2)$ C) $(-\infty, 4)$
D) $\{2, 4\}$ E) $(4, \infty)$

$$71. f(x) = e^{2x} + x^9 + \ln e$$

$$\Rightarrow f^{(10)}(x) = ?$$

- A) $e^{2x+9!}$ B) $e^{2x \cdot 9!}$ C) $2^9 \cdot e^{2x+9!}$
D) $2^9 \cdot e^x$ E) $2^{10} \cdot e^{2x}$

K
U
A
R
K
Y
A
Y
I
N
L
A
R
I

K
U
A
R
K
P
U
B
L
I
C
A
T
I
O
N
S

$$72. f(x) = \int (x^3 + 4)d(\ln x) \Rightarrow f'(1) = ?$$

- A) 4 B) 5 C) 6 D) 7 E) 8

73.

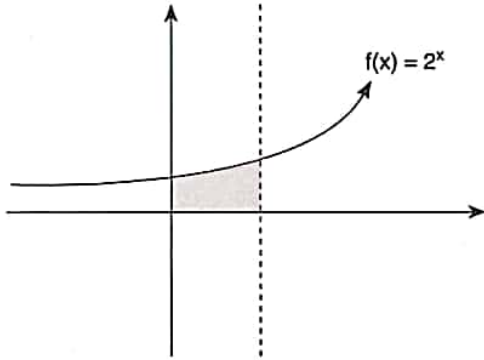

- A) $8\ln 2$ B) $4\ln 2$ C) $\frac{1}{\ln 8}$ D) $\frac{7}{\ln 2}$ E) $\frac{2}{\ln 2}$

75.

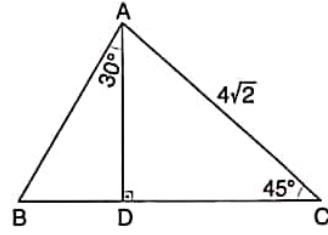

$[AD] \perp [BC]$, $m(\widehat{BAD}) = 30^\circ$, $m(\widehat{ACD}) = 45^\circ$
 $|AC| = 4\sqrt{2} \text{ cm} \Rightarrow |AB| = ? \text{ cm}$

- A) $\frac{8\sqrt{3}}{3}$ B) $4\sqrt{3}$ C) $6\sqrt{3}$
 D) $5\sqrt{3}$ E) $6\sqrt{6}$

76.

$$\frac{|AE|}{|EB|} = 3,$$

$$\frac{|AD|}{|DC|} = \frac{2}{3}$$

$$\Rightarrow \frac{TA(SA)}{A(\triangle ABC)} = ?$$

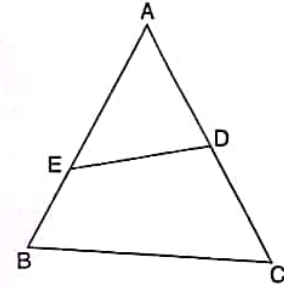

- A) $\frac{1}{5}$ B) $\frac{2}{5}$ C) $\frac{3}{10}$ D) $\frac{1}{2}$ E) $\frac{1}{4}$

74.

$$\begin{bmatrix} e^x & e^x \\ 2 & e^x \end{bmatrix} = A$$

$$|A| = 8 \Rightarrow x = ?$$

- A) $\ln 2$ B) $2\ln 2$ C) 2 D) e^2 E) $e \cdot \ln 2$

77.

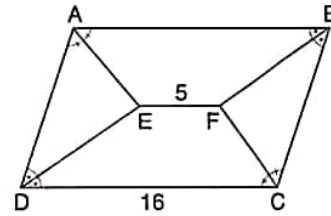

ABCD bir paralelkenardır. / ABCD is a parallelogram.

$$m(\widehat{DAE}) = m(\widehat{EAB}), \quad m(\widehat{DCF}) = m(\widehat{FCB}),$$

$$m(\widehat{ADE}) = m(\widehat{EDC}), \quad m(\widehat{ABF}) = m(\widehat{FBC}),$$

$$|EF| = 5 \text{ cm}, \quad |DC| = 16 \text{ cm} \Rightarrow |BC| = ? \text{ cm}$$

- A) 9 B) 10 C) 10,5 D) 11 E) 11,5

YÖS

12

78.

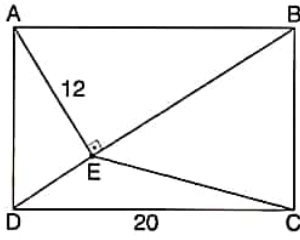

ABCD bir dikdörtgendir. / ABCD is a rectangle.

$[AE] \perp [BD]$,

$IAEI = 12 \text{ cm}$,

$IDCI = 20 \text{ cm}$

\Rightarrow Taralı alan / The Shaded Area = ? cm^2

- A) 36 B) 42 C) 48 D) 54 E) 60

79.

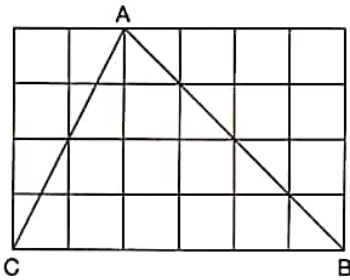

Eş karelerden oluşan yukarıdaki düzlemde;
ABC üçgeninin çevrel çemberinin yarıçapı kaç
br'tir?

In the plane above consisting of equally shaped
squares, what is the radius of the circumscribed circle
of the triangle ABC?

- A) 2 B) 3 C) $\sqrt{10}$ D) $\frac{\sqrt{6}}{2}$ E) $\frac{\sqrt{5}}{3}$

80. Yandaki şeklin çevresi
56 br olduğuna göre,
şeklin kapatılması ile
oluşacak küpün hacmi
kaç br^3 tür?

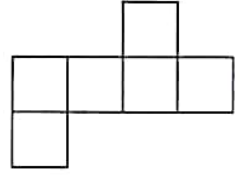

If the area of the figure
beside is 56 u, how many u^3
is the volume of the cube formed
when the figure unfolds?

- A) 8 B) 7 C) 56 D) 64 E) 81

K
U
A
R
K
Y
A
Y
I
N
L
A
R
IK
U
A
R
K
P
U
B
L
I
C
A
T
I
O
N
S

1. $a, b \in \mathbb{Z}^+$,
 $100 - a = b^3$
 $\Rightarrow \min(a + b) = ?$
 A) 15 B) 18 C) 20 D) 24 E) 30

3. Bir şirket \$1'lık ve \$2'lık ampullerden toplamı \$800 edecek şekilde sipariş veriyor. \$1'lık ampullerin sayısının 2 katı kadar \$2'lık ampul siparişi verildiyse, toplamda kaç ampul siparişi verilmiştir?
 A company ordered \$800 of light bulbs some of the light bulbs cost \$1 each and the others cost \$2 each. If twice as many \$1 bulbs as \$2 bulbs were ordered, how many bulbs were ordered altogether?

- A) 360 B) 480 C) 540 D) 600 E) 660

K
U
A
R
K
Y
A
Y
I
N
L
A
R
IK
U
A
R
K
P
U
B
L
I
C
A
T
I
O
N
S

2. $(5877 \cdot 9213 - 1) = A$,

$$\begin{array}{r} A \overline{) 5} \\ \underline{ } \\ x \end{array} \Rightarrow x = ?$$

- A) 0 B) 1 C) 2 D) 3 E) 4

4. $\left[2 + \frac{1}{1 - 2^{-1}} \right]^{-1} = ?$

- A) $-\frac{1}{4}$ B) -1 C) 1 D) $\frac{1}{4}$ E) 4

YÖS

13

5. $a, b \in \mathbb{Z}^+$,

$$a^2 - b^2 = 19 \Rightarrow \frac{a \cdot b}{2} = ?$$

- A) 10 B) 15 C) 25 D) 30 E) 45

7. $9^{2x-y+2} = 4 \Rightarrow 3^{2x-y+1} = ?$

- A)
- $\frac{1}{3}$
- B)
- $\frac{2}{3}$
- C) 1 D)
- $\frac{4}{3}$
- E)
- $\frac{5}{3}$

K
U
A
R
K
Y
A
Y
I
N
L
A
R
IK
U
A
R
K
P
U
B
L
I
C
A
T
I
O
N
S

6. $\frac{a-b}{\sqrt{a}-\sqrt{b}} - \sqrt{b} = 2 \Rightarrow a = ?$

- A) 1 B) 2 C) 3 D) 4 E) 5

8. $\left. \begin{array}{l} x^{k-t} = 20 \\ x^{k+t} = 5 \end{array} \right\} \Rightarrow x^k - x^t = ?$

- A) 18 B)
- $\frac{19}{2}$
- C) 19 D) 21 E)
- $\frac{23}{2}$

9. $\sqrt[3]{\frac{1}{27}} \sqrt{\frac{1}{3}} \sqrt{81} = \frac{1}{3^x} \Rightarrow x = ?$

- A) $-\frac{3}{5}$ B) $-\frac{5}{6}$ C) $-\frac{6}{5}$ D) $\frac{5}{6}$ E) $\frac{6}{5}$

10. Çınar'ın da aralarında bulunduğu 7 kişilik bir sporcu grubundan oluşturulacak 3 kişilik ekiplerin kaç tanesinde Çınar bulunur?

How many teams of 3 people in which Çınar is a member of can be chosen from among 7 athletes that contain Çınar?

- A) 12 B) 15 C) 18 D) 20 E) 35

11. $\frac{(0,0002)^3 \cdot (0,005)^2}{50 \cdot (0,001)^6} = ?$

- A) 1 B) 4 C) 8 D) 40 E) 100

12. $a, b, c \in \mathbb{Z}^-$,

$$\frac{a}{0,1} = \frac{b}{0,2} = \frac{c}{0,5} \Rightarrow \max(a+b+c) = ?$$

- A) -6 B) -8 C) -10 D) -14 E) -16

13. $f(x) = ax + b$

$$f^{-1}(2) = 4, f^{-1}(1) = 2$$

$$\Rightarrow f(16) = ?$$

- A) 1 B) 2 C) 4 D) 8 E) 16

14. $a, b, c \in \mathbb{Z}$,

$$-2 \leq a < 8,$$

$$3 < b \leq 10,$$

$$-1 < c < 4 \Rightarrow \max(a \cdot b - c) = ?$$

- A) 68 B) 69 C) 70 D) 71 E) 72

YÖS

13

15. $|x + 4| < x + 6 \Rightarrow \text{ÇK(SS)} = ?$

- A) $(-6, -4)$ B) $(-4, \infty)$ C) $(-5, \infty)$
 D) $(-\infty, 6)$ E) $(4, 6)$

18. $2 \cdot \left(\frac{2}{\log_2 12} + \frac{1}{\log_3 12} \right) = ?$

- A) $\frac{1}{4}$ B) $\frac{1}{2}$ C) 1 D) 2 E) 4

K
U
A
R
K
Y
A
Y
I
N
L
A
R
I

16. $n \in \mathbb{N}$,

$$P(x) = 2x^{\frac{20}{n}} - 3x^{\frac{n+16}{n}} + x^{n-4} \Rightarrow n = ?$$

- A) 4 B) 6 C) 14 D) 16 E) 30

19. $z \cdot i + 4 = z \Rightarrow \frac{4}{z} = ?$

- A) $\frac{1+i}{2}$ B) $2 + 2i$ C) $2 - 2i$
 D) $1 - i$ E) $\frac{1-i}{2}$

K
U
A
R
K
P
U
B
L
I
C
A
T
I
O
N
S

17. $f(x) = ax^2 + 4x - b$,

$f(x_1) = f(x_2) = 0$,

$x_1 = x_2 \Rightarrow a \cdot b = ?$

- A) -12 B) -8 C) -4 D) -2 E) 6

20. $\prod_{k=5}^{18} \frac{k-3}{k-2} = ?$

- A) $\frac{1}{16}$ B) $\frac{1}{8}$ C) $\frac{1}{4}$ D) $\frac{1}{2}$ E) 1

YÖS

13

21. $(x - 2y)^6 = x^6 - \dots Ax^3y^3 + \dots$

$\Rightarrow A = ?$

- A) -180 B) -160 C) -140 D) -120 E) 160

22. $f(x) = \tan x \cdot \cot x + \sin x \Rightarrow f\left(\frac{7\pi}{6}\right) = ?$

- A) $-\frac{1}{2}$ B) -1 C) 0 D) $\frac{1}{2}$ E) 1

23. $\sin\left(2\arcsin\frac{3}{5}\right) = ?$

- A) $\frac{16}{17}$ B) $\frac{17}{18}$ C) $\frac{20}{21}$ D) $\frac{24}{25}$ E) $\frac{25}{26}$

24. $f(x) = \begin{cases} 2x-1, & x < 0 \\ x+1, & 0 < x < 2 \\ 3x-2, & x > 2 \end{cases}$

$\Rightarrow \lim_{x \rightarrow 0^+} f(x) + \lim_{x \rightarrow 2^+} f(x) = ?$

- A) 1 B) 2 C) 3 D) 4 E) 5

25. $\lim_{x \rightarrow -\infty} \left(e^{-x} + \left(\frac{1}{2}\right)^x + 3 \right) = ?$

- A) $-\infty$ B) -3 C) 0 D) 3 E) ∞

26. $\frac{d^2}{dx^2} [3x^3 - 2x^2 + 16x] = ?$

- A) $27x^2 - 4x$
 B) $27x^2 - 4x + 16$
 C) $18x - 4$
 D) $18x$
 E) 27

K
U
A
R
K
Y
A
Y
I
N
L
A
R
IK
U
A
R
K
P
U
B
L
I
C
A
T
I
O
N
S

YÖS

13

27. $f(x) = e^{2x} \cdot \sin x \Rightarrow f'(x) = ?$

- A) $e^x(\sin x + \cos x)$
 B) $e^{2x}(\sin x + \cos x)$
 C) $e^{4x}(\sin x + 2\cos x)$
 D) $e^{2x}(2\sin x + \cos x)$
 E) $2e^{2x}(\sin x + \cos x)$

28. $\int x f(x) dx = 6x^2 + 8x + c \Rightarrow f(2) = ?$

- A) 2 B) 4 C) 8 D) 12 E) 16

29. $\int_1^6 |x-2| dx = ?$

- A) $\frac{17}{2}$ B) $\frac{19}{2}$ C) $\frac{21}{2}$ D) $\frac{23}{2}$ E) $\frac{25}{2}$

30. $A = \begin{bmatrix} -2 & 3 & 4 & 5 \\ 1 & 0 & 2 & 4 \\ 0 & -1 & 0 & 6 \\ 4 & 3 & 2 & -1 \end{bmatrix}, B = \begin{bmatrix} 0 & 3 & 2 & 3 \\ -2 & -1 & -4 & 1 \\ -3 & -2 & 0 & 0 \\ 0 & 1 & 2 & 3 \end{bmatrix}$

$$A \cdot B = \begin{bmatrix} \cdot & \cdot & a & \cdot \\ \cdot & \cdot & \cdot & \cdot \\ \cdot & \cdot & \cdot & \cdot \\ \cdot & \cdot & \cdot & b \end{bmatrix} = a + b = ?$$

- A) -6 B) -4 C) 4 D) 6 E) 8

K
U
A
R
K
Y
A
Y
I
N
L
A
R
IK
U
A
R
K
P
U
B
L
I
C
A
T
I
O
N
S

31.

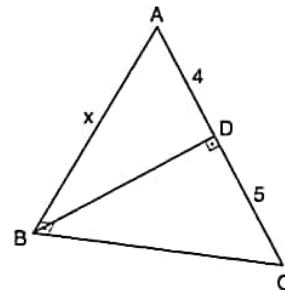

$[AB] \perp [BC], [BD] \perp [AC], IADI = 4 \text{ cm}, IDCI = 5 \text{ cm}$
 $\Rightarrow IABI = x = ? \text{ cm}$

- A) 2 B) 4 C) 6 D) 8 E) 10

YÖS

13

32.

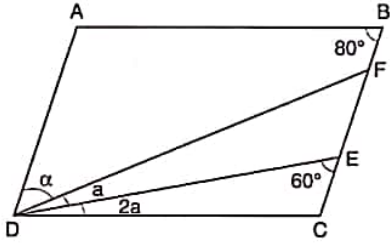

$[AB] \parallel [DC], [AD] \parallel [BC], m(\widehat{FDE}) = a,$
 $m(\widehat{EDC}) = 2a,$

$m(\widehat{B}) = 80^\circ, m(\widehat{DEC}) = 60^\circ \Rightarrow \alpha = ?$

A) 30° B) 40° C) 50° D) 60° E) 70°

34.

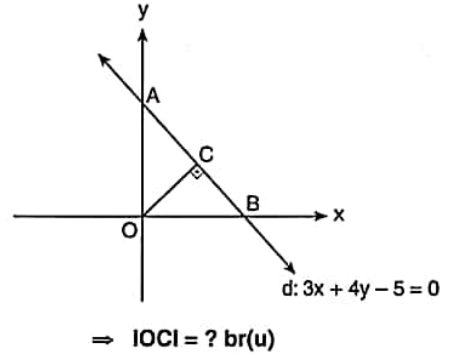

A) $\frac{1}{5}$ B) $\frac{1}{2}$ C) 1 D) 2 E) 2,5

33. ABCDEF bir düzgün altıgendir.

ABCDEF is a regular hexagon.

$IAFI = IFKI = IAKI$

$\Rightarrow \frac{A+B}{A(ABCDEF)} = ?$

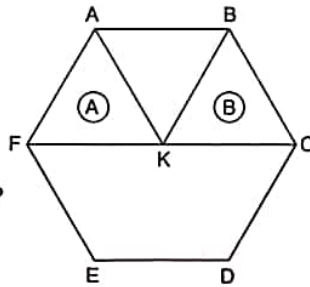

A) $\frac{1}{6}$ B) $\frac{1}{9}$ C) $\frac{1}{4}$ D) $\frac{1}{3}$ E) $\frac{1}{2}$

35. O noktası şekildeki (ABK, O) dik konisinin merkezidir.

Point O is the center of the right cone (ABK, O) in the figure.

$[CD] \parallel [AB]$

$IKCI = ICAI,$

$V_2 = 84 br^3(u^3),$

$\Rightarrow V_1 = ? br^3(u^3)$

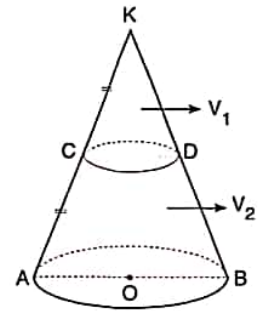

A) 7 B) 12 C) 14 D) 16 E) 18

36, 37, 38 ve 39. sorularda I. gruptaki her bir harf, rakam veya şekil, II. gruptaki farklı birer harf, rakam veya şekil ile gösterilmiştir. Buna göre, soru işaretleriyle belirtilen harfleri, rakamları veya şekilleri bulunuz. In questions 36, 37, 38 and 39 each letter, numeral or figure in group I stand for a different letter, numeral or figure in group II. Accordingly, find the letters, numerals or figures which the questions mark stands for.

36.

I.	II.
A T A	8 9 8
K E K	2 1 2
Ş İ Ş	5 9 5
M U M	3 5 3
T E T	4 7 4

= KEK = ?

- A) 898 B) 212 C) 585 D) 353 E) 474

37.

I.	II.
S A L İ	8 2 5 7
B O R G	0 2 4 9
C İ M A	2 6 7 8
G İ B S	4 3 1 0
İ L A C	9 7 6 2

= CİMBOM = ?

- A) 824534 B) 825435 C) 024964
D) 825345 E) 025435

38.

I.	II.
H İ Z M A	3 4 9 8 5
K E M A N	4 2 8 5 7
T İ K E M	0 1 2 5 7
İ Z E M A	5 7 6 1 0
M A N İ H	9 8 5 7 6

= NAZIM = ?

- A) 67213 B) 67215 C) 60723
D) 94083 E) 67315

39.

I.	II.
B A R İ S	9 0 7 4 5
S E Y A N	5 4 1 0 3
Y İ L T E	2 0 9 4 1
L E S A T	8 4 3 6 9
N A T E R	7 6 2 1 0

= TAYLAN = ?

- A) 147253 B) 147245 C) 127425
D) 147545 E) 147243

K U A R K Y A Y I N L A R I

K U A R K P U B L İ C A T İ O N S

40 ve 41. sorulardaki verilen işlemlerde her harf sıfırdan ve birbirinden farklı birer rakamı göstermektedir. Buna göre, soru işareti ile belirtilen harf ya da işlemin değerini bulunuz.

In the operations which are given in questions 40 and 41 each letter stands for a different non-zero numeral. Accordingly, find the value of the letter or operation indicated by the questions mark.

40.
$$\begin{array}{r} KL \\ + LK \\ \hline 143 \end{array} \quad K < L \quad \Rightarrow \max(KL) = ?$$

A) 49 B) 58 C) 68 D) 67 E) 94

41.
$$\begin{array}{r} K \\ \times L \\ \hline N \end{array} \quad \begin{array}{r} K \\ \times M \\ \hline P \end{array} \quad \Rightarrow (N + P) = ?$$

A) 10 B) 11 C) 12 D) 13 E) 14

42. I. $a \blacksquare b = a^x \cdot b^y$

II. $n \blacksquare (m \blacksquare n) = ?$

Yukarıdaki birinci eşitlikte \blacksquare işaretinin görevi verilmiştir. Buna göre, ikinci eşitlikteki soru işaretinin yerine aşağıdakilerden hangisi gelmelidir?

In the first equation above, the function of \blacksquare is given. Accordingly, which of the following does the question mark stand for in the second equation?

A) $m^{x^2+y} \cdot n^{xy}$ B) $m^{x+y^2} \cdot n^{xy}$ C) $m^{x^2} \cdot n^{x^2}$
D) $n^{x+y^2} \cdot m^{xy}$ E) $n^{x+y} \cdot m^{x-y}$

K
U
A
R
K
Y
A
Y
I
N
L
A
R
IK
U
A
R
K
P
U
B
L
I
C
A
T
I
O
N
S

43. I. $a \Delta b = a + 2b$

II. $a \odot b = 2a - b$

III. $(2 \Delta 3) \odot ((-2) \Delta (-3)) = ?$

Yukarıdaki eşitliklerde Δ ve \odot işaretlerinin görevleri verilmiştir. Buna göre, üçüncü eşitlikteki soru işaretinin yerine aşağıdaki sayılardan hangisi gelmelidir?

In the equations above, the functions of Δ and \odot are given. Accordingly, which of the following numbers does the question mark stand for in the third equation?

A) 16 B) 18 C) 20 D) 22 E) 24

44. I. $x^y * y^x = \frac{x+y}{2}$
II. $(125 * 243) = ?$

Yukarıdaki birinci eşitlikte * işaretinin görevi verilmiştir. Buna göre, ikinci eşitlikteki soru işaretinin yerine aşağıdaki sayılardan hangisi gelmelidir?

In the first equation above, the function of * is given. Accordingly, which of the following numbers does the question mark stand for in the second equation?

- A) 3 B) 4 C) 5 D) 6 E) 7

45. I. $1245 \square 2 = 144$
II. $3041 \square 1 = 8$
III. $2021 \square 3 = 125$
IV. $1234 \square 0 = ?$

Yukarıdaki eşitliklerde \square işaretinin görevi verilmiştir. Buna göre, dördüncü eşitlikteki soru işaretinin yerine aşağıdaki sayılardan hangisi gelmelidir?

In the equations above, the function of \square is given. Accordingly, which of the following numbers does the question mark stand for in the fourth equation?

- A) 1 B) 10 C) 100 D) 125 E) 600

46. I. $98 \blacktriangle 47 = 131$
II. $76 \blacktriangle 14 = 82$
III. $81 \blacktriangle 20 = 101$
IV. $43 \blacktriangle 21 = ?$

Yukarıdaki eşitliklerde \blacktriangle işaretinin görevi verilmiştir. Buna göre, dördüncü eşitlikteki soru işaretinin yerine aşağıdaki sayılardan hangisi gelmelidir?

In the equations above, the function of \blacktriangle is given. Accordingly, which of the following numbers does the question mark stand for in the fourth equation?

- A) 46 B) 49 C) 58 D) 62 E) 74

K
U
A
R
K
Y
A
Y
I
N
L
A
R
I

K
U
A
R
K
P
U
B
L
I
C
A
T
I
O
N
S

47. 25 28 34 35 37 ?

Yukarıda verilen sayı dizisinde soru işaretinin yerine getirilmesi gereken sayıyı bulunuz.

Find the number which the question mark stands for in the given number sequence above.

- A) 37 B) 39 C) 41 D) 43 E) 46

YÖS

13

48.

+	a	b	c	d	e
K					5
L			6		
M		8			
N				3	
T	4				

$$\Rightarrow (K + L + M + N + T) + (a + b + c + d + e) = ?$$

Yukarıdaki toplama tablosunda K, L, M, N, T, a, b, c, d, ve e harfleri pozitif birer tam sayının yerine kullanılmıştır. Buna göre, $(K + L + M + N + T) + (a + b + c + d + e)$ kaçtır?

In the summation table above, the letters K, L, M, N, T, a, b, c, d, and e each stands for a positive integer. Accordingly, what is the value of $(K + L + M + N + T) + (a + b + c + d + e)$?

- A) 20 B) 23 C) 26 D) 28 E) 30

49.

x	a	b	c
a			2b
b			
c			b ²

$$\Rightarrow a = ?$$

Yukarıdaki çarpma tablosunda a, b ve c harfleri pozitif birer tam sayının yerine kullanılmıştır. Buna göre, a kaçtır?

In the multiplication table above, the letters a, b and c each stands for a positive integer. Accordingly, what is the value of a?

- A) 1 B) 2 C) 3 D) 4 E) 5

50.

+	a	b	c
a		3c + 1	29
b	c + 19		
c			

x	a	b	c
a			
b	K		
c			

$$\Rightarrow K = ?$$

Yukarıdaki toplama ve çarpma tablolarında a, b ve c harfleri pozitif birer tam sayının yerine kullanılmıştır. Buna göre, K kaçtır?

In the summation and multiplication tables above, the letters a, b and c each stands for a positive integer. Accordingly, what is the value of K?

- A) 100 B) 120 C) 140 D) 150 E) 160

51.

13	15	51	11	12
9	13	38	15	1
21	0	37	14	2
32	3	78	40	?

Yukarıdaki tablodaki soru işaretinin yerine aşağıdaki sayılardan hangisi gelmelidir?

Which of the following numbers does the question mark stand for in the table above?

- A) 2 B) 3 C) 6 D) 8 E) 16

K U A R K Y A Y I N L A R I

K U A R K P U B L I C A T I O N S

52.

4			10	
				?
	18		22	

Yukarıdaki tablodaki soru işaretinin yerine aşağıdaki sayılardan hangisi gelmelidir?

Which of the following numbers does the question mark stand for in the table above?

- A) 20 B) 21 C) 22 D) 23 E) 24

53 ve 54. soruları aşağıdaki şekle göre cevaplayınız.

Answer questions 53 ve 54, in accordance with the figure given below.

Her soru birbirinden bağımsız olarak cevaplanacaktır.

Each question is to be answered independently.

K	$K+L+M$
$K+L$	$L+M$
20	L
M	

Yukarıdaki şekil K, L ve M harfleriyle gösterilen üç pozitif tam sayıyı içeren bazı işlemlere göre düzenlenmiştir. Harflerin gösterdiği sayılar her soruda farklı olabilir; fakat yapılacak işlemler her soruda aynıdır.

The figure above has been organized according to various operations using three positive integers represented by the letters K, L and M. The integers represented by the letters may change from question to question, but the operations to be done remain the same.

53.

K	?
16	18
$K+M$	L
M	

- A) 20 B) 23 C) 26 D) 27 E) 29

54.

$2M-L$?
$2L-2$	L
$L+5$	
M	

- A) 25 B) 26 C) 27 D) 28 E) 29

YÖS

13

55.

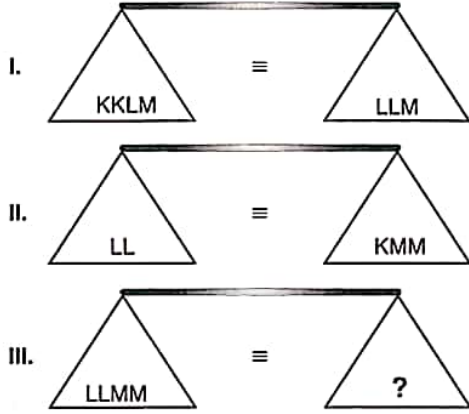

Yukarıdaki terazilerin üçü de dengededir. Buna göre, III. terazideki soru işaretini aşağıdakilerden hangisi göstermektedir?

All three scales above are in balance. Accordingly, which of the following does the question mark stand for in the third scale?

- A) K B) 2-K C) 4-K D) 5-K E) 7-K

56.

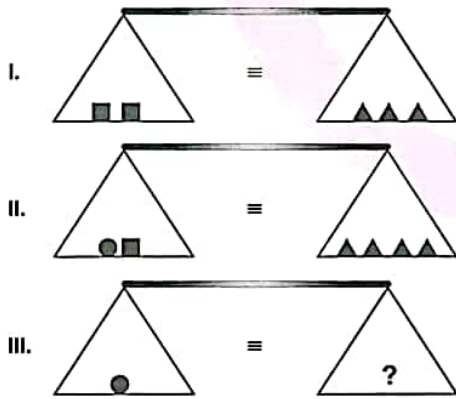

Yukarıdaki terazilerin üçü de dengededir. Buna göre, III. terazideki soru işaretini aşağıdakilerden hangisi göstermektedir?

All three scales above are in balance. Accordingly, which of the following does the question mark stand for in the third scale?

- A) ▲ B) ■ C) ▲▲
D) ■▲ E) ▲▲■

57.

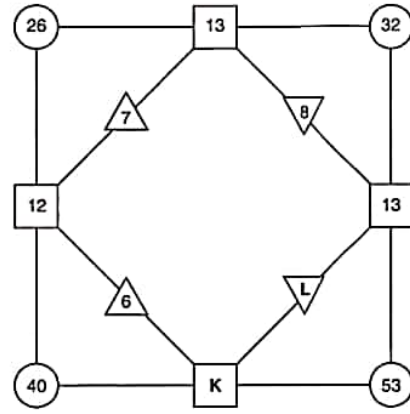

$$\Rightarrow K + L = ?$$

Yukarıdaki sayı-şekil ilişkisine göre K + L kaçtır?

According to the number-figure relation above, what is the value of K + L?

- A) 15 B) 16 C) 17 D) 18 E) 19

58.

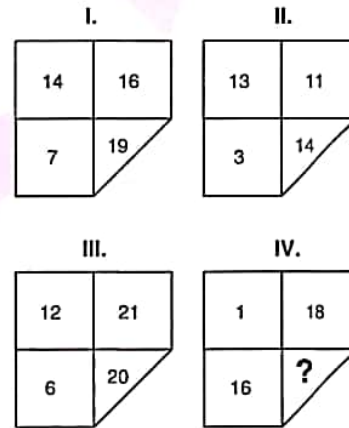

I, II ve III. şekillerde verilen kurala göre, IV. şekildeki soru işaretinin yerine aşağıdaki sayılardan hangisi gelmelidir?

Which of the following numbers does the question mark stand for in figure IV, in accordance with the rule established in figure I, II and III?

- A) 17 B) 18 C) 19 D) 20 E) 21

K U A R K Y A Y I N L A R I

K U A R K P U B L I C A T I O N S

59.

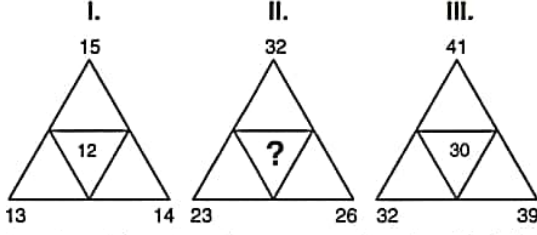

I. ve III. şekillerde verilen kurala göre, II. şekildeki soru işaretinin yerine aşağıdaki sayılardan hangisi gelmelidir?

Which of the following numbers does the question mark stand for in figure II, in accordance with the rule established in figure I and III?

- A) 11 B) 14 C) 17 D) 20 E) 2

60.

	2★●●	3●□□	2□●★
1★★□	★□		★●
2●●□	-	K	M
3□★●	L		-

⇒ K ; L ; M = ? ; ? ; ?

Yukarıdaki tabloya göre K, L ve M aşağıdakilerden hangisidir?

According to the table above, which of the following stands for K, L and M?

- A) - ; - ; ●□ B) - ; ●□ ; □●
 C) ●□ ; - ; □● D) - ; ●□ ; -
 E) ●□ ; ●□ ; □●

61.

K	L	X	K	P	Q
P	M	L	M	N	M
K	N	X	Q	P	N
K	P	X	M	P	K
N	Q	N	P	M	L

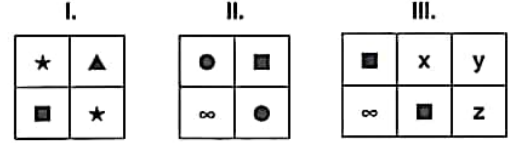

I, II ve III yukarıdaki tablonun farklı birer parçasıdır. Buna göre, x, y ve z aşağıdakilerden hangisidir?

I, II and III are three different parts of the table above. Accordingly, which of the following does x, y and z stand for?

- A)

M	K
	L

 B)

P	K
	L

 C)

M	P
	L

 D)

M	P
	L

 E)

M	P
	K

YÖS

13

62. Aşağıdaki şekillerden hangisi bir özelliğine göre diğerlerinden farklıdır?

Which of the following figure is different than the others accordingly to a certain property?

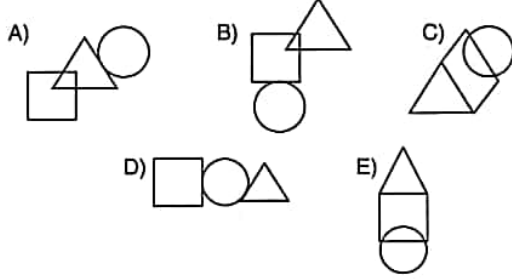

63 ve 64. sorularda, verilen her bir şekil matrisindeki soru işaretinin yerine hangi şeklin getirilmesi gerektiğini bulunuz.

In questions 63 and 64 find the figure which should replace the question mark in each given figure matrix.

63.

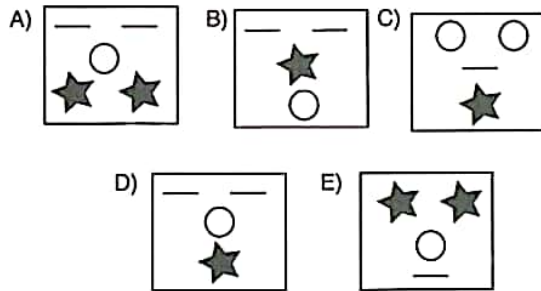
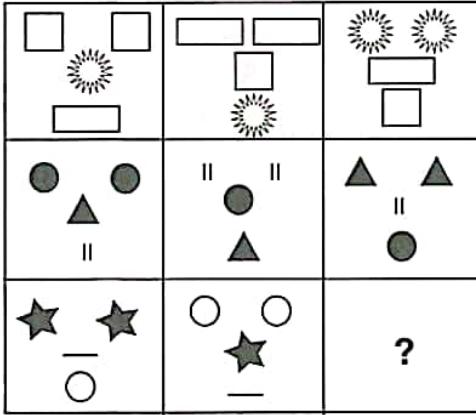

64.

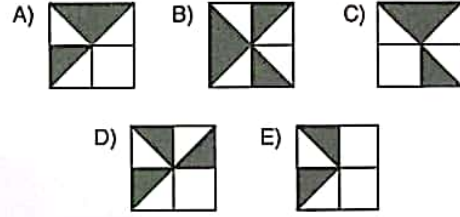
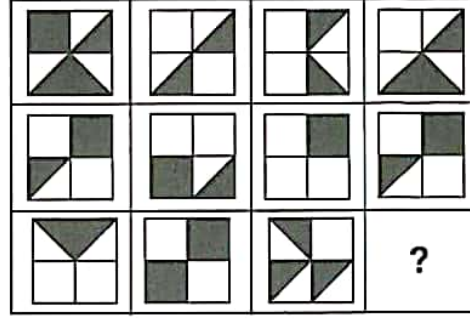

65, 66 ve 67. sorularda, I. satırda belirlenen ilişkiye göre II. satırı hangi şeklin tamamladığını bulunuz.

In questions 65, 66 and 67, find the figure which completes row II in accordance with the relation in row I.

65.

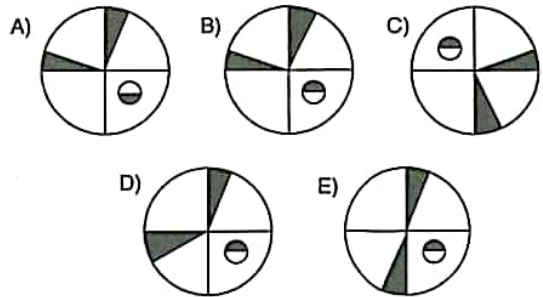
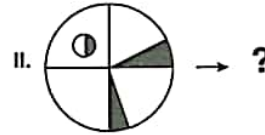
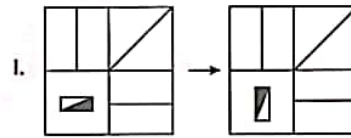

YÖS

13

66.

23	13	16	7	8	11
14	48	56	65	29	30
102	111	143	61	66	8
46	47	37	1	2	0

I.

→ 23|13|7|11|29|61|47|37|2

90	141	108	17	21	23
40	41	49	59	60	70
78	235	492	222	100	0
19	27	2	1	3	43

II.

→ ?

A) 17|23|41|59|19|2|1|3|43

B) 2|3|17|19|23|41|46|59

C) 17|23|41|59|19|3|43

D) 17|23|41|59|19|2|3|43

E) 141|17|23|41|59|19|2|3|43

67.

●	■	*	*	▲
⊗	●	⊗	*	▲
●	▲	+	■	▲
*	■	▲	*	+
+	▲	+	●	⊗

I.

→ ●;*≡ ⊗*⊕▲⊗*■●

a	c	d	a	f
b	c	f	d	a
f	b	e	b	e
c	d	f	d	f
e	f	e	a	f

II.

→ a; e ≡ ?

A) (b) — (f) — (d) — (e) — (f)

B) (b) — (f) — (e) — (d) — (f) — (a)

C) (c) — (d) — (b) — (f) — (e) — (a)

D) (b) — (f) — (d) — (e) — (f) — (e)

E) (f) — (f) — (d) — (f) — (e) — (f)

68.

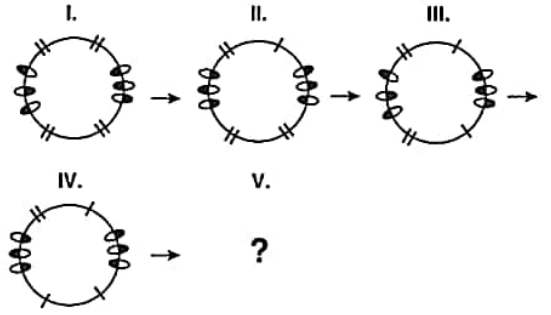

Yukarıdaki şekil dizisine göre, soru işaretinin yerine aşağıdaki şekillerden hangisi gelmelidir?
Which of the following figure does the question mark stand for, according to the figure sequence above?

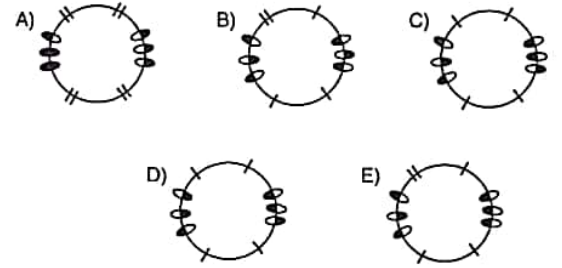
K
U
A
R
K
Y
A
Y
I
N
L
A
R
IK
U
A
R
K
P
U
B
L
I
C
A
T
I
O
N
S

YÖS

13

69 ve 70. sorularda, soru işaretinin yerine getirilmesi gereken şekli bulunuz.

In question 69 and 70, find the figure to replace the question mark.

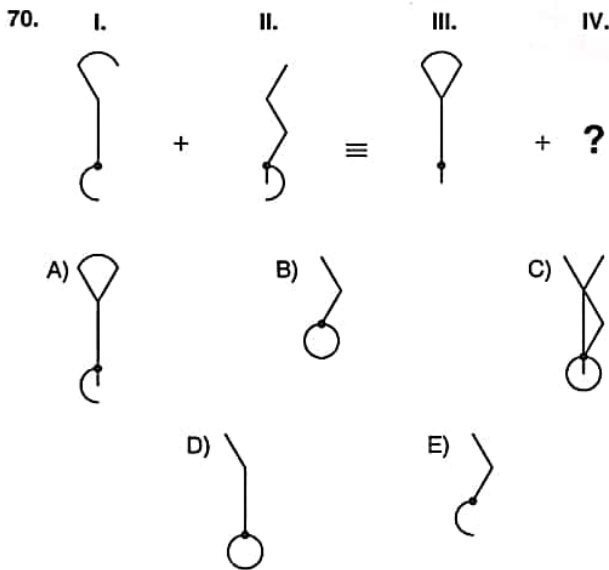
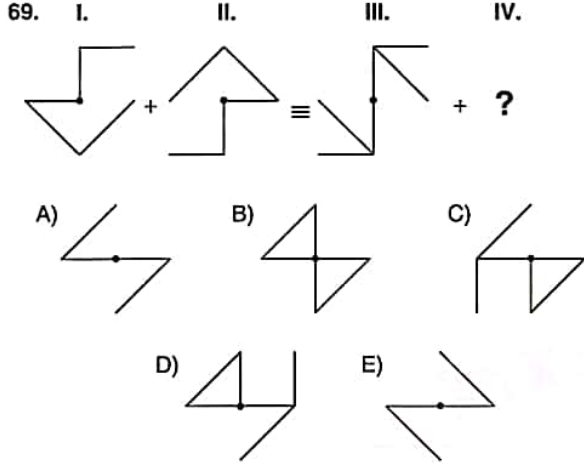

71 ve 72. soruları aşağıdaki örnekte verilen ilişkiye göre cevaplayınız.

Answer questions 71 and 72, in accordance with the relation established in the example below.

ÖRNEK / EXAMPLE:

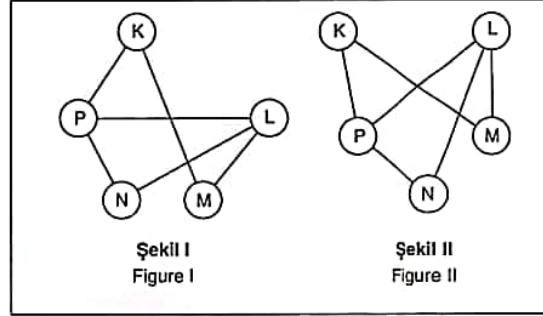

K, L, M, N ve P harfleri I. şekildeki gibi birbirine bağlanmıştır. I. şekildeki bağlantı sayıları ve birbirine bağlanan harfler değişmemek koşuluyla II. şekil elde edilmiştir.

The letters K, L, M, N and P are linked as in figure I. figure II. has been constructed so as not to change the number of links and the letters that are linked to each other in figure I.

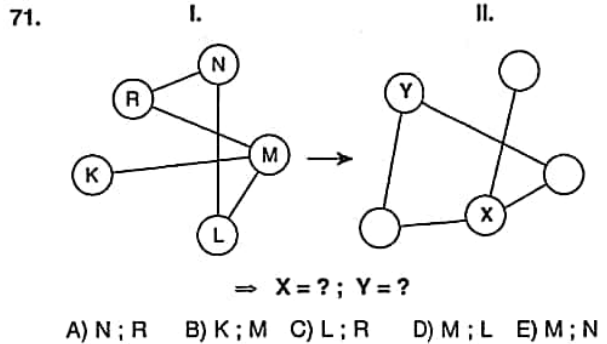

72.

I.

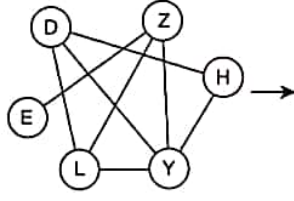

II.

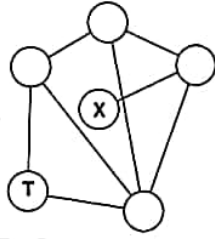
 $\Rightarrow X = ? ; T = ?$

- A) H;Y B) H;L C) D;E D) E;H E) Z;Y

74.

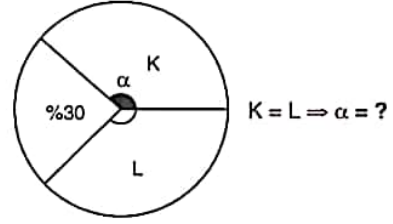

Yukarıdaki dairesel grafikte verilen bilgilere göre, α kaçtır?

According to the information in the circular chart above, what is the value of α ?

- A) 100° B) 110° C) 116° D) 126° E) 135°

73.

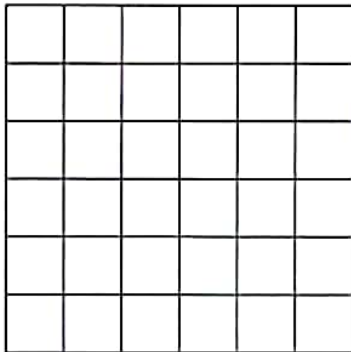

Yukarıdaki şekilde kaç tane kare vardır?
How many squares exist in the table above?

- A) 36 B) 41 C) 91 D) 96 E) 102

75.

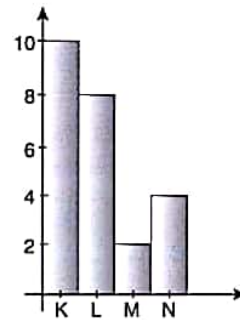

$$K + L + M - N = 80 \Rightarrow K - M = ?$$

Yukarıdaki sütun grafikte verilen bilgilere göre, $K - M$ kaçtır?

According to the information in the column chart above, what is the value of $K - M$?

- A) 5 B) 15 C) 25 D) 30 E) 40

YÖS

13

76 ve 77. soruları aşağıdaki örnekte verilen ilişkiye göre cevaplayınız.

Answer questions 76 and 77, in accordance with the relation established in the example below.

ÖRNEK / EXAMPLE:

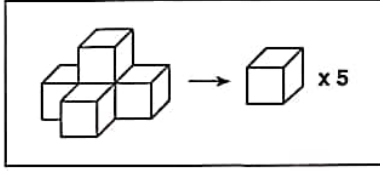

76.

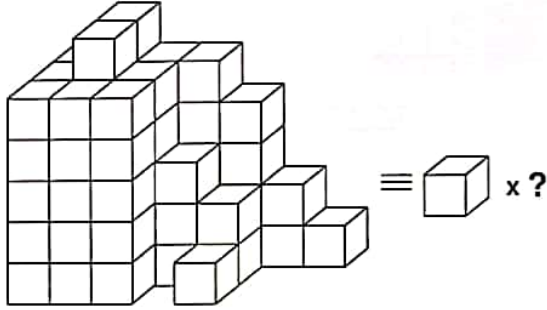

A) 64 B) 65 C) 66 D) 67 E) 68

77.

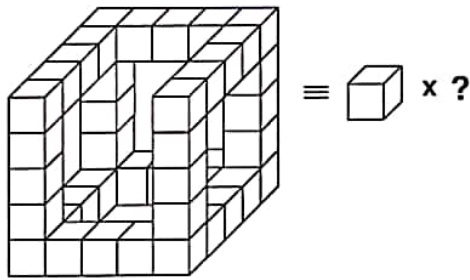

A) 40 B) 41 C) 42 D) 43 E) 44

78. soruyu aşağıdaki örnekte verilen ilişkiye göre cevaplayınız.

Answer question 78, in accordance with the relation established in the example below.

ÖRNEK / EXAMPLE:

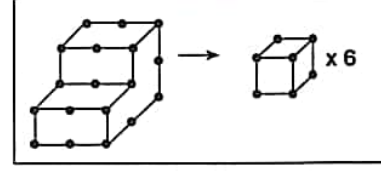

78.

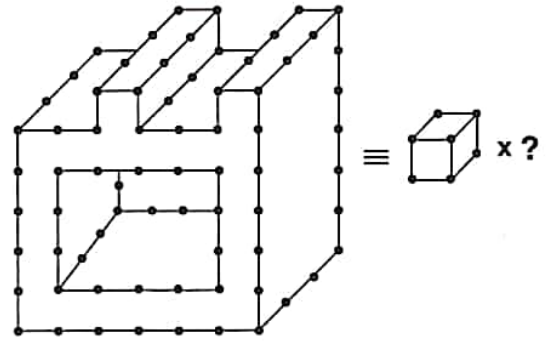

A) 54 B) 57 C) 60 D) 63 E) 69

K U A R K Y A Y I N L A R I

K U A R K P U B L I C A T I O N S

YÖS

13

79.

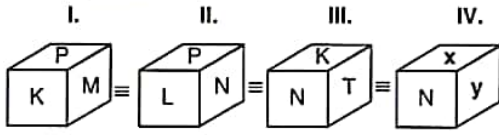

$$= x; y = ?; ?$$

Yukarıdaki şekillerin tümü aynı nesneyi göstermektedir. Buna göre x ve y aşağıdakilerinden hangisidir?

The figures above all represent the same object. Accordingly, which of the following stands for x and y, respectively?

- A) K; P B) L; P C) T; K D) K; M E) L; T

80.

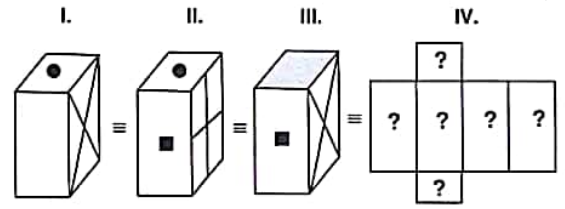

Yukarıdaki şekillerin tümü aynı prizmayı göstermektedir. Buna göre, aşağıdakilerden hangisi bu prizmanın açılmış halidir?

The figures represent the same prism above.

Accordingly, which of the following represents the unfolded form of this prism?

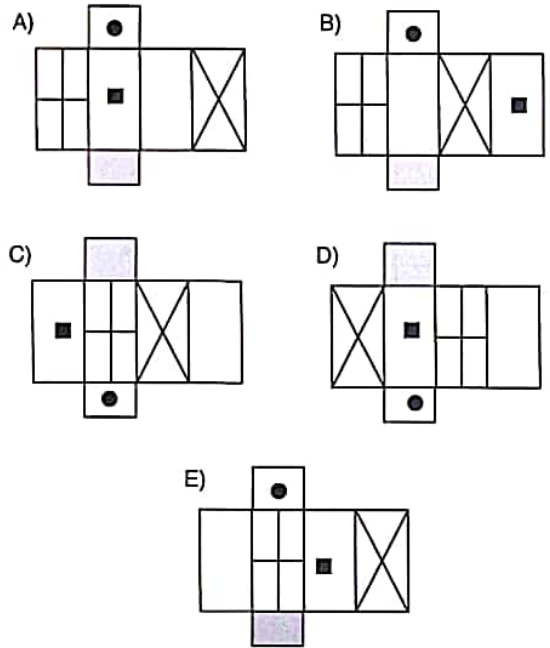

K U A R K Y A Y I N L A R I

K U A R K P U B L I C A T I O N S

1, 2, 3, 4 ve 5. sorularda I. gruptaki her bir harf, rakam veya şekil, II. gruptaki farklı birer harf, rakam veya şekil ile gösterilmiştir. Buna göre, soru işaretiyle belirtilen harfleri, rakamları veya şekilleri bulunuz.

In questions 1, 2, 3, 4 and 5 each letter, numeral or figure in group I stand for a different letter, numeral or figure in group II. Accordingly, find the letters, numerals or figures which the questions mark stands for.

1.

I.	II.
3 2 9 0	○ → □ ⇒
0 3 7 6	⇒ ✓ → ○
4 2 1 9	→ ○ ⇒ □
9 0 6 7	⊕ ✓ ↗ →
0 8 5 7	○ + ▲ □

$$\Rightarrow \square \blacktriangle \checkmark 80 = ?$$

- A) 572 □ + B) 527 □ ⊕ C) 752 ⊕ □
D) 752 + ○ E) 725 + □

2.

I.	II.
0 3 9 7 6	N C B L Ü
9 7 3 2 4	M S N T B
4 6 9 2 1	G M B Ç C
1 5 8 7 6	Ü S T Ç C
3 5 4 8 9	B Ç M L N

$$\Rightarrow \text{NGBSL} = ?$$

- A) 40952 B) 40816 C) 04958
D) 40726 E) 40916

3.

I.	II.
L C Ç N B	3 9 1 8 2
B C S N F	2 7 1 0 3
F M S Ç B	4 5 1 9 6
N F Ü B L	6 7 8 0 2
Ü T S M L	0 3 4 2 6

$$\Rightarrow 39872 = ?$$

- A) ÇFMCO B) FMÇCB C) NBMÇC
D) FMÇBC E) FMBFÇ

4.

I.	II.
5 0 2 4	⇒ ?
3 5 3 7	
7 4 2 0	
5 0 3 8	

- A) $\begin{matrix} \alpha & \beta & \uparrow & \heartsuit \\ \downarrow & \alpha & \downarrow & \rightarrow \\ \rightarrow & \heartsuit & \uparrow & \beta \\ \alpha & \beta & \downarrow & \leftarrow \end{matrix}$
- B) $\begin{matrix} \alpha & \beta & \uparrow & \heartsuit \\ \downarrow & \alpha & \downarrow & \rightarrow \\ \rightarrow & \heartsuit & \uparrow & \rightarrow \\ \alpha & \beta & \uparrow & \leftarrow \end{matrix}$
- C) $\begin{matrix} \alpha & \rightarrow & \uparrow & \heartsuit \\ \downarrow & \alpha & \downarrow & \rightarrow \\ \rightarrow & \heartsuit & \uparrow & \rightarrow \\ \alpha & \rightarrow & \downarrow & \leftarrow \end{matrix}$
- D) $\begin{matrix} \alpha & \beta & \uparrow & \heartsuit \\ \downarrow & \alpha & \downarrow & \leftarrow \\ \rightarrow & \heartsuit & \uparrow & \rightarrow \\ \alpha & \rightarrow & \downarrow & \leftarrow \end{matrix}$
- E) $\begin{matrix} \alpha & \beta & \uparrow & \heartsuit \\ \downarrow & \alpha & \downarrow & \rightarrow \\ \rightarrow & \heartsuit & \uparrow & \rightarrow \\ \alpha & \rightarrow & \downarrow & \leftarrow \end{matrix}$

5.

I.

■	✓	↗	⊕
⊙	♥	*	■
*	□	⊕	X
✓	■	♥	⊙

II.

?

A)

5	3	9	7
6	0	1	5
1	2	7	8
3	5	0	6

B)

5	3	9	8
6	0	1	5
1	2	8	7
3	5	1	6

C)

5	3	7	9
6	0	1	5
1	2	7	8
3	5	0	6

D)

5	3	9	9
6	0	1	5
1	2	7	8
5	5	0	6

E)

3	5	9	7
6	0	1	5
1	2	8	7
3	5	0	6

6.

I. $(x, y) \blacktriangle (a, b) = x \cdot a + b \cdot y$

II. $(3, 4) \blacktriangle (6, 8) = ?$

Yukarıdaki birinci eşitlikte \blacktriangle işaretinin görevi verilmiştir. Buna göre, ikinci eşitlikteki soru işaretinin yerine aşağıdaki sayılardan hangisi gelmelidir?

In the first equation above, the function of \blacktriangle is given. Accordingly, which of the following numbers does the question mark stand for in the second equation?

A) 44 B) 46 C) 48 D) 50 E) 52

7.

I. $(3 - a) \star (2 + b) = a \cdot b$

II. $(a + 4) \square (5 - b) = 2 \cdot a + b$

III. $(2 \star 5) + (7 \square 3) = ?$

Yukarıdaki eşitliklerde \square ve \star işaretlerinin görevleri verilmiştir. Buna göre, üçüncü eşitlikteki soru işaretinin yerine aşağıdaki sayılardan hangisi gelmelidir?

In the equations above, the functions of \square and \star are given. Accordingly, which of the following numbers does the question mark stand for in the third equation?

A) 10 B) 11 C) 12 D) 13 E) 14

K U A R K Y A Y I N L A R I

K U A R K P U B L I C A T I O N S

8.

I. $a \odot b = \frac{(a \oplus b) + 6}{a + b + 1}$

II. $4 \odot 2 = ?$

Yukarıdaki birinci eşitlikte \odot işaretinin görevi verilmiştir. Buna göre, ikinci eşitlikteki soru işaretinin yerine aşağıdaki sayılardan hangisi gelmelidir?

In the first equation above, the function of \odot is given. Accordingly, which of the following numbers does the question mark stand for in the second equation?

A) 1 B) 2 C) 3 D) 4 E) 5

YÖS

14

9. I. $4 \bullet 5 = 27$
 II. $6 \bullet 8 = 42$
 III. $9 \bullet 2 = 33$
 IV. $5 \bullet 9 = ?$

Yukarıdaki eşitliklerde \bullet işaretinin görevi verilmiştir. Buna göre, dördüncü eşitlikteki soru işaretinin yerine aşağıdaki sayılardan hangisi gelmelidir?

In the equations above, the function of \bullet is given. Accordingly, which of the following numbers does the question mark stand for in the fourth equation?

- A) 33 B) 36 C) 39 D) 42 E) 45

10. I. $2 \oslash 6 = \frac{1}{3}$
 II. $3 \oslash 7 = \frac{4}{21}$
 III. $4 \oslash 10 = \frac{3}{20}$
 IV. $5 \oslash 8 = ?$

Yukarıdaki eşitliklerde \oslash işaretinin görevi verilmiştir. Buna göre, dördüncü eşitlikteki soru işaretinin yerine aşağıdaki sayılardan hangisi gelmelidir?

In the equations above, the function of \oslash is given. Accordingly, which of the following numbers does the question mark stand for in the fourth equation?

- A) $\frac{3}{40}$ B) $\frac{1}{10}$ C) $\frac{1}{13}$ D) $\frac{3}{10}$ E) $\frac{13}{40}$

11. 10 12 17 25 36 ? 67

Yukarıda verilen sayı dizisinde soru işaretinin yerine getirilmesi gereken sayıyı bulunuz.

Find the number which the question mark stands for in the given number sequence.

- A) 46 B) 47 C) 48 D) 49 E) 50

12, 13, 14 ve 15. sorulardaki verilen işlemlerde her harf sıfırdan ve birbirinden farklı birer rakamı göstermektedir. Buna göre, soru işareti ile belirtilen harf ya da işlemin değerini bulunuz.

In the operations which are given in questions 12, 13, 14 and 15 each letter stands for a different numeral and different from zero. Accordingly, find the value of the letter or operation indicated by the questions mark.

$$\begin{array}{r}
 \text{K L M} \\
 - \text{L 8} \\
 \hline
 1 \text{ K 2} \\
 \text{---} \\
 - \text{1 L L} \\
 \hline
 1 \text{ 8}
 \end{array}
 \Rightarrow \text{K} \cdot \text{L} = ?$$

- A) 16 B) 20 C) 24 D) 28 E) 32

$$\begin{array}{r}
 \text{M L K} \\
 - \text{L K M} \\
 \hline
 \text{K 0 6}
 \end{array}
 \Rightarrow \text{L} = ?$$

- A) 1 B) 2 C) 3 D) 4 E) 5

YÖS

14

$$\begin{array}{r}
 L L K \\
 + K K L \\
 \hline
 M L L M
 \end{array}
 \Rightarrow K + L + M = ?$$

- A) 8 B) 9 C) 10 D) 11 E) 12

$$\begin{array}{r}
 UFO \\
 \times 57 \\
 \hline
 29\bullet\bullet \\
 + \bullet\bullet 15 \\
 \hline
 \bullet 41 A 1
 \end{array}
 \Rightarrow A + U + F + O = ?$$

- A) 8 B) 9 C) 10 D) 11 E) 12

16.

+	a	b	c
a	$\frac{c}{2}$		
b	$c-10$	4	
c			

$$\Rightarrow a = ?$$

Yukarıdaki toplama tablosunda a, b ve c harfleri pozitif birer tam sayının yerine kullanılmıştır. Buna göre, a kaçtır?

In the summation table above, the letters a, b and c each stands for a positive integer. Accordingly, what is the value of a?

- A) 2 B) 4 C) 8 D) 16 E) 32

17.

x	a	b	c
a			243
b	c		
c		a^7	

$$\Rightarrow a + b = ?$$

Yukarıdaki çarpma tablosunda a, b ve c harfleri pozitif birer tam sayının yerine kullanılmıştır. Buna göre, a + b kaçtır?

In the multiplication table above, the letters a, b and c each stands for a positive integer. Accordingly, what is the value of a + b?

- A) 108 B) 96 C) 30 D) 27 E) 15

18.

x	a	b	c
a	$20-b$	c	
b		$c/2$	
c			

$$\Rightarrow a + b + c = ?$$

Yukarıdaki çarpma tablosunda a, b ve c harfleri pozitif birer tam sayının yerine kullanılmıştır. Buna göre, a + b + c kaçtır?

In the multiplication table above, the letters a, b and c each stands for a positive integer. Accordingly, what is the value of a + b + c?

- A) 80 B) 75 C) 70 D) 65 E) 60

K
U
A
R
K
Y
A
Y
I
N
L
A
R
IK
U
A
R
K
P
U
B
L
I
C
A
T
I
O
N
S

YÖS

14

19.

9	5	4	8
7	3	2	6
8	6	7	9
6	2	?	9

Yukarıdaki tablodaki soru işaretinin yerine, aşağıdaki sayılardan hangisi gelmelidir?

Which of the following numbers does the question mark stand for in the table above?

- A) 1 B) 2 C) 3 D) 4 E) 5

20, 21 ve 22. soruları aşağıdaki şekle göre cevaplayınız.

Answer questions 20, 21 and 22 in accordance with the figure given below.

Hersoru birbirinden bağımsız olarak cevaplanacaktır.
Each question is to be answered independently.

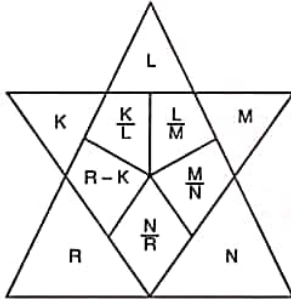

$$K \neq L \neq M \neq N \neq R \in Z$$

Yukarıdaki şekil K, L, M, N ve R harfleriyle gösterilen birbirinden farklı beş tamsayı içeren bazı işlemlere göre düzenlenmiştir. Harflerin gösterdiği sayılar her soruda farklı olabilir; fakat, bunlarla yapılacak işlemler her soruda aynıdır.

The figure above has been organized according to various operations using five different integers represented by the letters, K, L, M, N and R. The integers represented by the letters may change from question to question, but the operations to be done remain the same.

20.

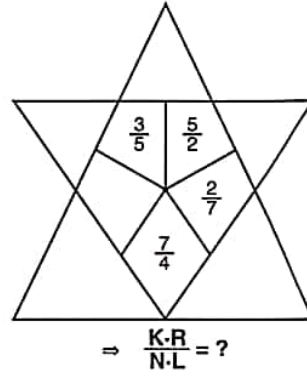

$$\Rightarrow \frac{K \cdot R}{N \cdot L} = ?$$

- A) $\frac{12}{35}$ B) $\frac{6}{35}$ C) $\frac{3}{14}$ D) $\frac{5}{14}$ E) $\frac{15}{14}$

21.

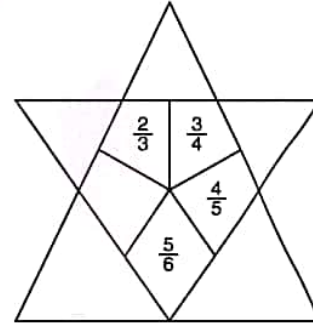

$$\Rightarrow \frac{K}{R} = ?$$

- A) $\frac{1}{6}$ B) $\frac{1}{5}$ C) $\frac{1}{4}$ D) $\frac{1}{3}$ E) $\frac{1}{2}$

22.

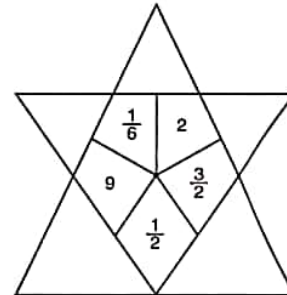

$$\Rightarrow \frac{L^2 \cdot R}{N \cdot L} = ?$$

- A) 48 B) 36 C) 32 D) 24 E) 18

K U A R K Y A Y I N L A R I

K U A R K P U B L I C A T I O N S

23.

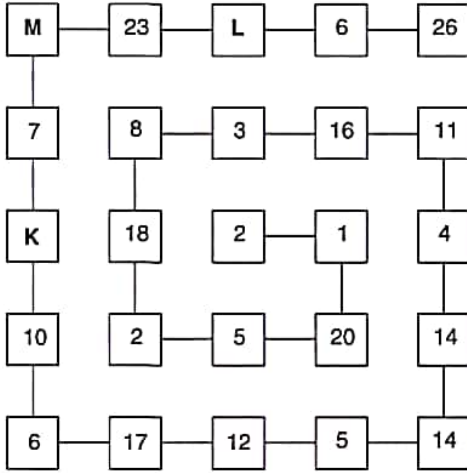

$$\Rightarrow K + L + M = ?$$

Yukarıdaki sayı-şekil ilişkisine göre $K + L + M$ kaçtır?

What is the value of $K + L + M$ according to the number-figure relation above?

- A) 33 B) 34 C) 35 D) 36 E) 37

24.

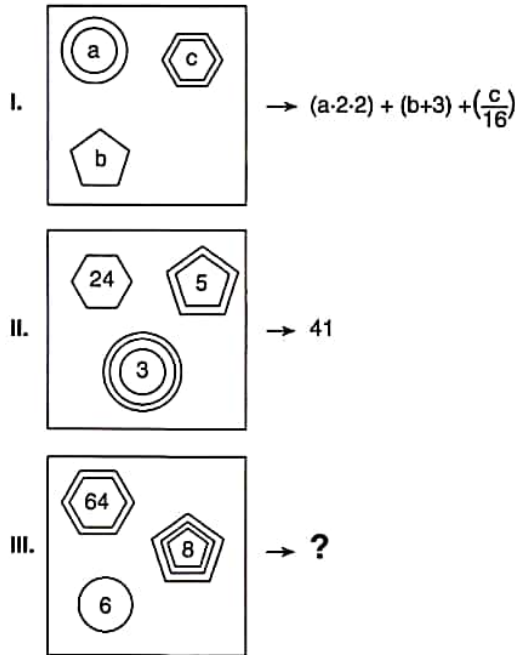

I. ve II. satırlarda belirlenen ilişkiye göre, III. satırı aşağıdaki sayılardan hangisi tamamlar?

Which of the following numbers completes III, in accordance with the relation established in I and II?

- A) 31 B) 32 C) 33 D) 34 E) 35

25.

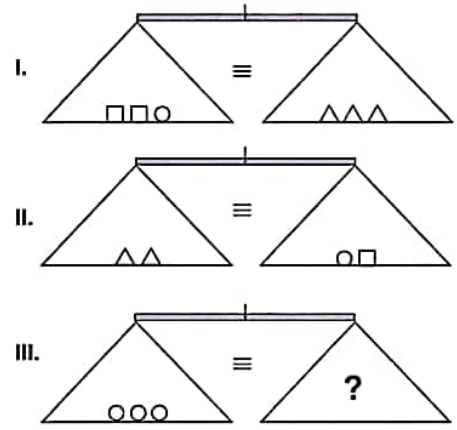

Yukarıdaki terazilerin üçü de dengededir. Buna göre, III. terazideki soru işaretini aşağıdakilerden hangisi göstermektedir?

All three scales above are in balance. Accordingly, which of the following does the question mark stand for in the third scale?

- A) $\triangle \square \square$ B) $\square \square$ C) $\triangle \triangle$
D) \triangle E) \square

26.

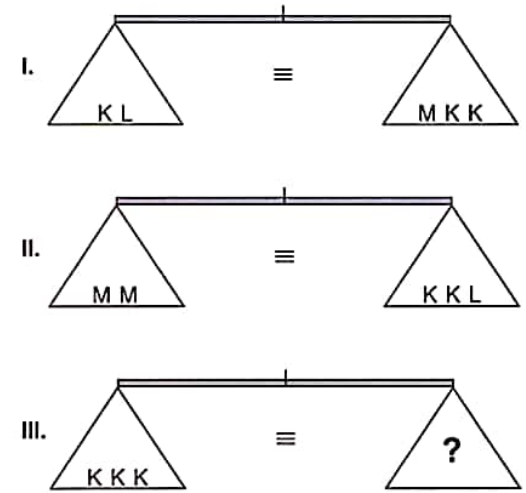

Yukarıdaki terazilerin üçü de dengededir. Buna göre, III. terazideki soru işaretini aşağıdakilerden hangisi göstermektedir?

All three scales above are in balance. Accordingly, which of the following does the question mark stand for in the third scale?

- A) L B) LL C) M
D) MM E) LM

YÖS

14

27.

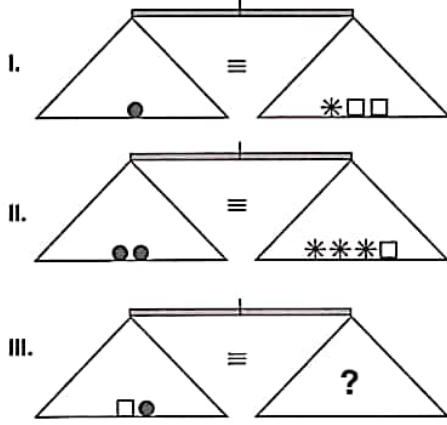

Yukarıdaki terazilerin üçü de dengededir. Buna göre, III. terazideki soru işaretini aşağıdakilerden hangisi göstermektedir?

All three scales above are in balance. Accordingly, which of the following does the question mark stand for in the third scale?

- A) □□ B) ●● C) *□
D) ** E) **●

28.

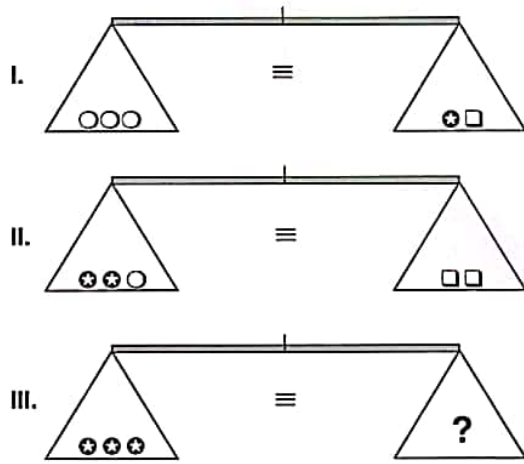

Yukarıdaki terazilerin üçü de dengededir. Buna göre, III. terazideki soru işaretini aşağıdakilerden hangisi göstermektedir?

All three scales above are in balance. Accordingly, which of the following does the question mark stand for in the third scale?

- A) ○ B) □ C) □□○
D) □○○ E) □□○○

29.

	K	L	M	N
▲	2	3	1	4
■	4	2	3	1
⊕	1	4	2	3
●	3	1	4	2

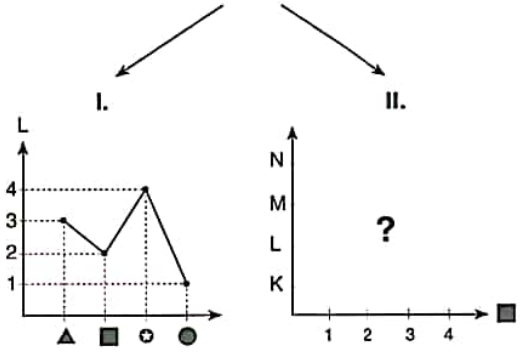

Yukarıda verilen I. ve II. grafikler tablodaki bilgilere göre düzenlenmiştir. Buna göre II. grafik aşağıdakilerden hangisidir?

Graphs I and II are organized according to the information given in the table above. Accordingly, which of the following stands for graph II?

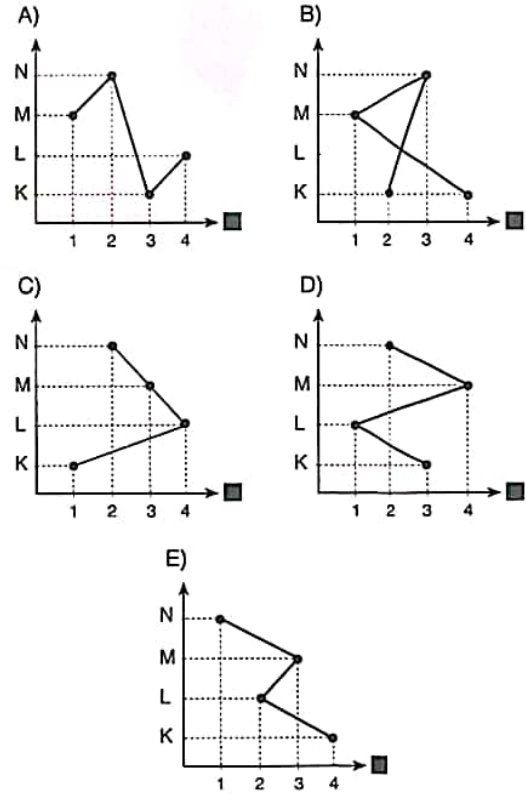

K U A R K Y A Y I N L A R I

K U A R K P U B L I C A T I O N S

YÖS

14

30.

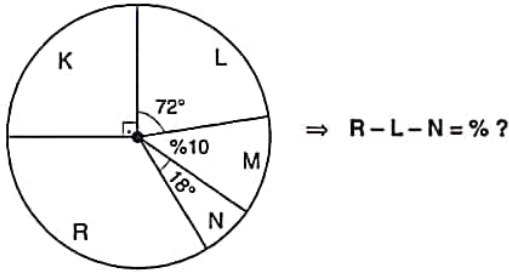

Yukarıdaki dairesel grafikte verilen bilgilere göre, R - L - N yüzde kaçtır?

According to the information in the circular chart above, what is the percentage of R - L - N ?

- A) 15 B) 20 C) 25 D) 30 E) 35

31.

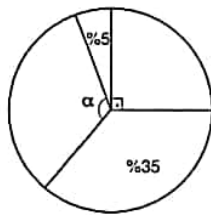

Yukarıdaki dairesel grafikte verilen bilgilere göre, α kaçtır?

According to the information in the circular chart above, what is the value of α ?

- A) 96° B) 108° C) 118°
D) 126° E) 144°

32.

I.

II.

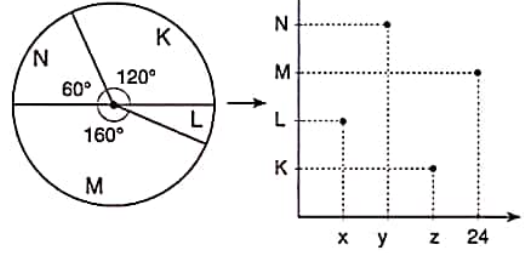

Yukarıda II. satırda verilen nokatsal grafik, I. şekil de dairesel grafiğe göre düzenlenmiştir. Buna göre $x + y - z$ kaçtır?

The dot-plot in figure II is organised according to the table in figure I. Accordingly, what is the value of $x + y - z$?

- A) -9 B) -6 C) -3 D) 3 E) 6

33.

I.

II.

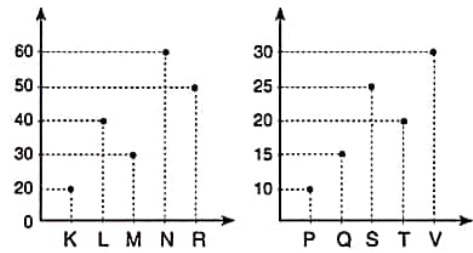

Yukarıdaki I. ve II. nokta grafikler arasındaki ilişkiye göre, M kaçtır?

What is the value of M, according to the relationship between dot charts I and II above?

- A) 4·P B) 2·Q C) $\frac{S}{5}$ D) $\frac{T}{2}$ E) V - 10

K U A R K Y A Y I N L A R I

K U A R K P U B L I C A T I O N S

YÖS

14

34.

	I	II	III
I	2	4	K
II	1	L	3
III	M	1	1

 $\Rightarrow K = ? ; L = ? ; M = ?$

Yukarıdaki tabloya göre K, L ve M kaçtır?

According to the table above, what are the value of K, L and M, respectively?

- A) 2 ; 3 ; 2 B) 2 ; 2 ; 3 C) 3 ; 2 ; 2
D) 3 ; 2 ; 3 E) 3 ; 3 ; 2

35.

	I	II	III
I	L		
II			K
III		M	

 $\Rightarrow K = ? ; L = ? ; M = ?$

Yukarıdaki tabloya göre K, L ve M aşağıdakilerden hangisidir?

According to the table above which of the following stands for K, L and M?

- | | K | L | M |
|----|---|---|---|
| A) | | | |
| B) | | | |
| C) | | | |
| D) | | | |
| E) | | | |

K U A R K Y A Y I N L A R I

K U A R K P U B L I C A T I O N S

YÖS

14

36, 37 ve 38. sorularda, verilen her bir şekil matrisindeki soru işaretinin yerine hangi şeklin getirilmesi gerektiğini bulunuz.

In questions 36, 37 and 38 find the figure which should replace the question mark in each given figure matrix.

36.

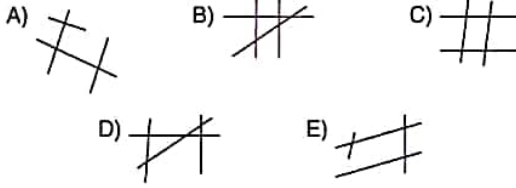
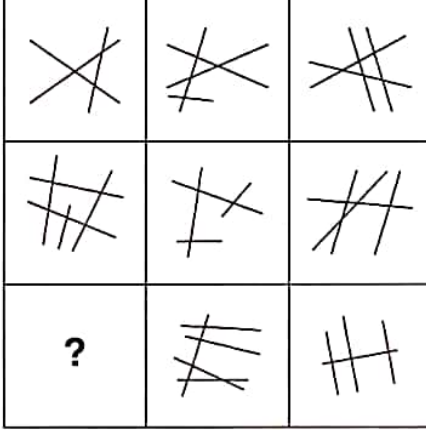

37.

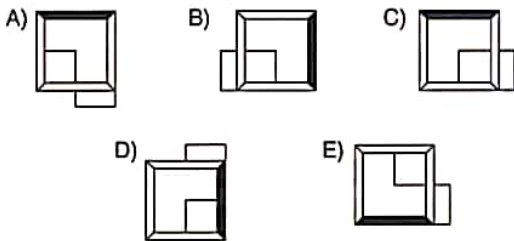
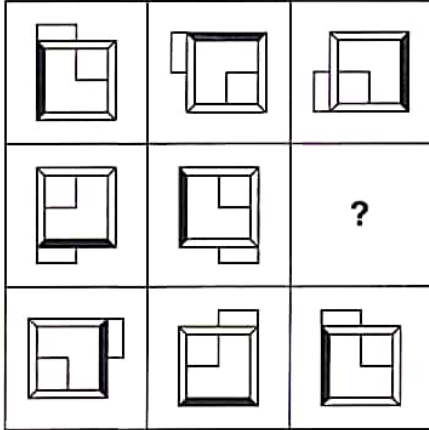

38.

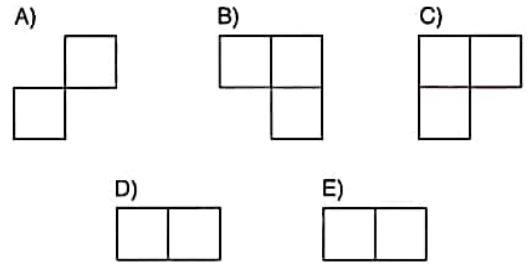
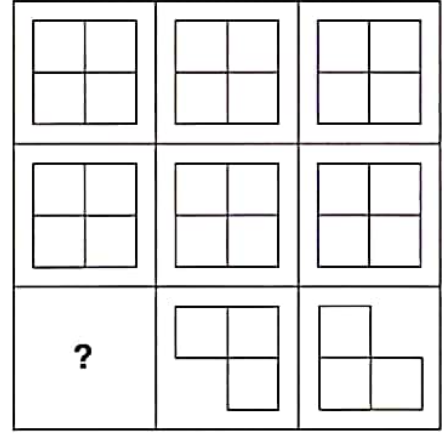

39, 40 ve 41. sorularda, verilen her şekil dizisindeki soru işaretinin yerine hangi şeklin getirilmesi gerektiğini bulunuz.

In questions 39, 40 and 41 find the figure which should replace the question mark in each given figure sequence.

39.

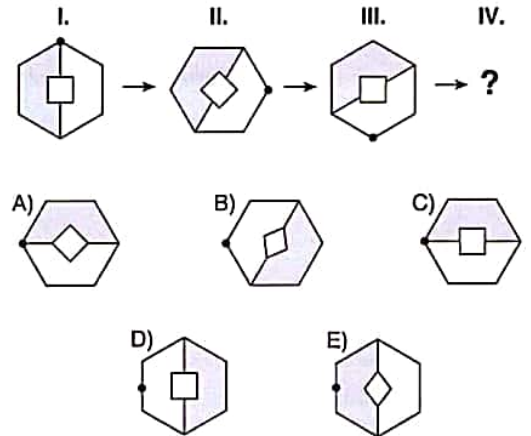

YÖS

14

40. I. II. III. IV.

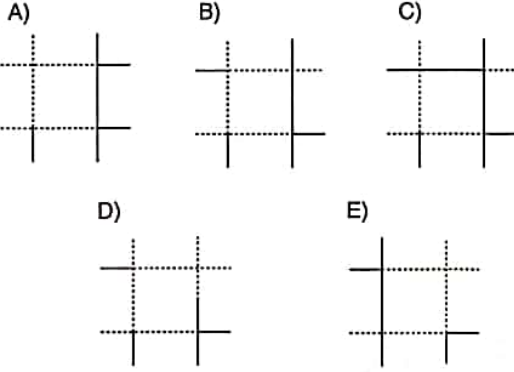
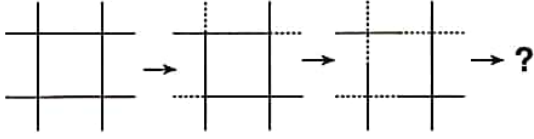

42 ve 43. sorularda, I. satırda belirlenen ilişkiye göre II. satırı hangi şeklin tamamladığını bulunuz.

In questions 42 and 43 find the figure which completes row II in accordance with the relation in row I.

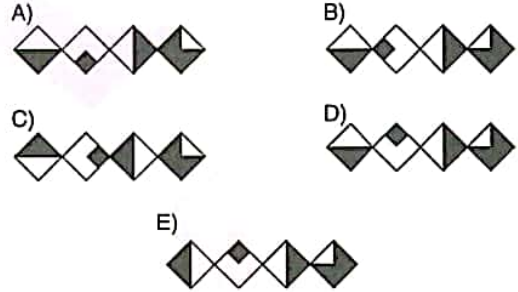
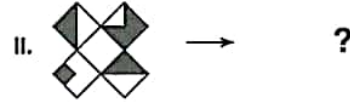
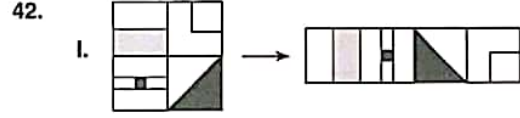

41. I. II. III.

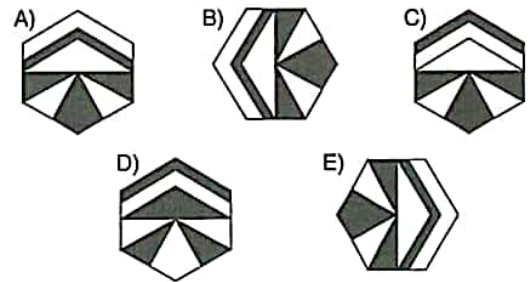
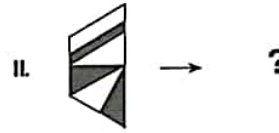
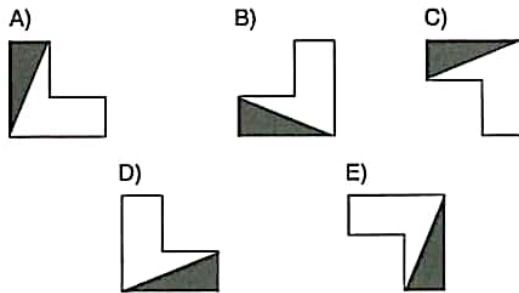
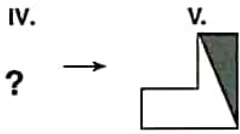

K U A R K Y A Y I N L A R I

K U A R K P U B L I C A T I O N S

YÖS

14

44.

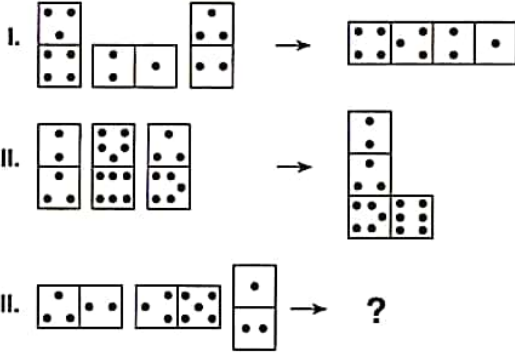

I. ve II. satırda belirlenen ilişkiye göre III. satırı hangi şeklin tamamladığını bulunuz.

Find the figure which completes row III, in accordance with the relation established in rows I and II.

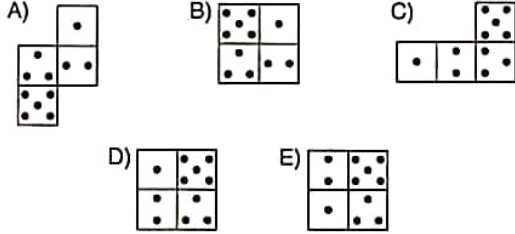

45, 46 ve 47. soruları aşağıdaki örnekte verilen ilişkiye göre cevaplayınız.

Answer questions 45, 46 and 47, in accordance with the relation established in the example below.

ÖRNEK / EXAMPLE:

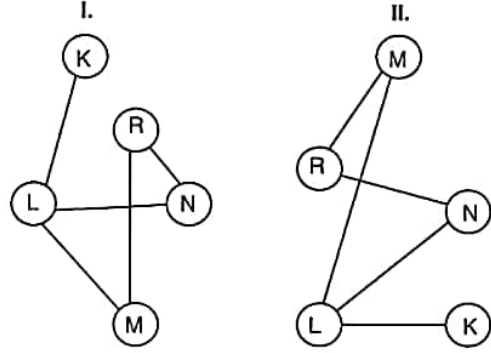

K, L, M, N ve R harfleri I. şekildeki gibi birbirine bağlanmıştır. I. şekildeki bağlantı sayıları ve birbirine bağlanan harfler değişmemek koşuluyla II. şekil elde edilmiştir.

The letters K, L, M, N ve R are linked as in figure I. figure II. has been constructed so as not to change which letters are linked to which, and the number of links made with each letter, in figure I.

45.

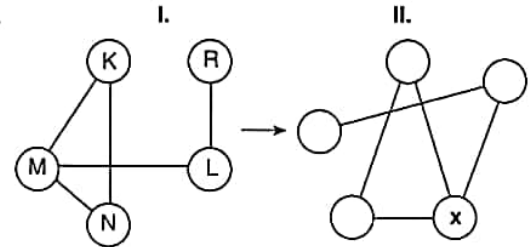

$\Rightarrow x = ?$

A) R B) N C) M D) L E) K

K U A R K Y A Y I N L A R I

K U A R K P U B L I C A T I O N S

YÖS

14

46.

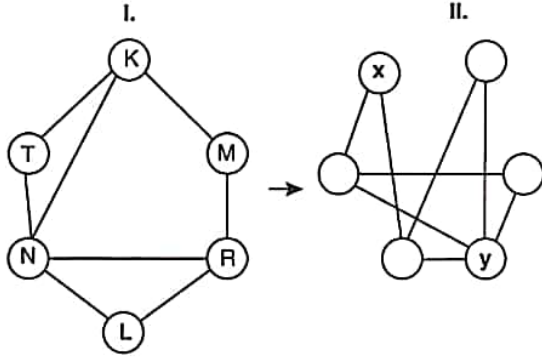
 $\Rightarrow x; y = ?$

A) L; M

B) T; M

C) M; R

D) L; R

E) M; N

48 ve 49. sorularda farklı olan şekli bulunuz.
Find the different figure in questions 48 and 49.

48. A) 1245 B) 840 C) 6251

D) 4431 E) 525

47.

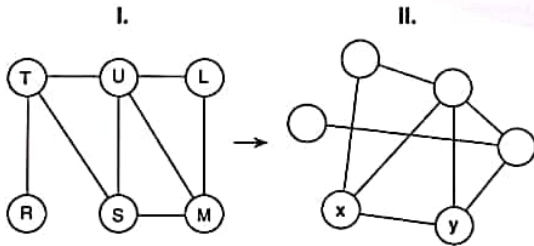
 $\Rightarrow x; y = ?$

	x	y
A)	S	M
B)	T	S
C)	S	T
D)	M	S
E)	M	T

49. A) B) C)

D) E)

50.

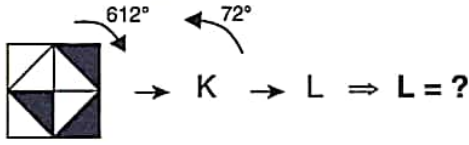

Yukarıdaki birinci şekil ok yönünde 612° döndürüldüğünde K şekli oluşuyor, K şekli ok yönünde 72° döndürüldüğünde ise L şekli oluşuyor. Buna göre, L şekli aşağıdakilerden hangisidir?

Figure K is formed by rotating the first figure above through 612° in the direction of the arrow and L is formed by rotating K through 72° in the direction of the arrow. Accordingly, which of the following does the figure L stand for?

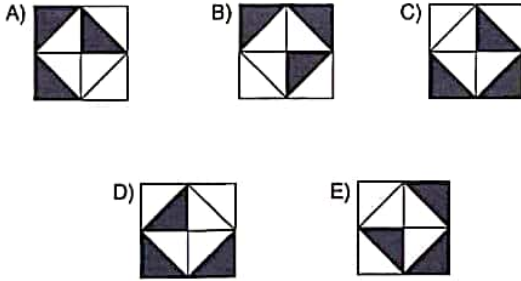

51, 52, 53 ve 54. sorularda, soru işaretinin yerine getirilmesi gereken şekli bulunuz.

In question 51, 52, 53 and 54, find the figure to replace the question mark.

51.

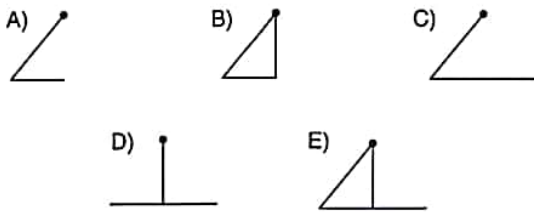
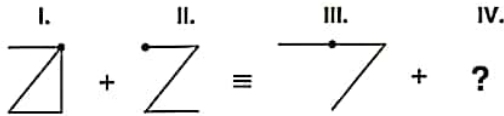

52.

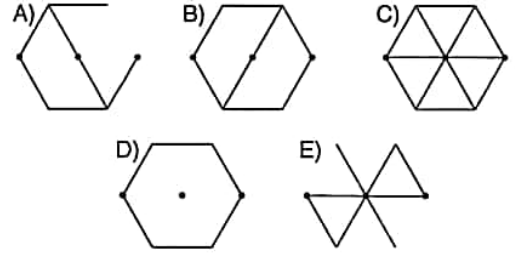
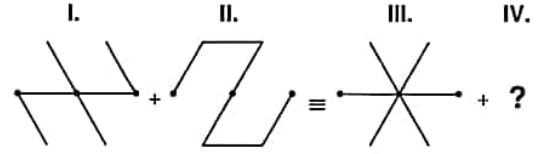

53.

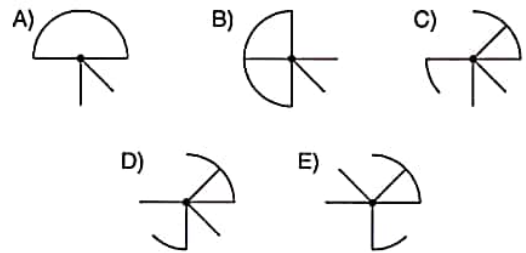
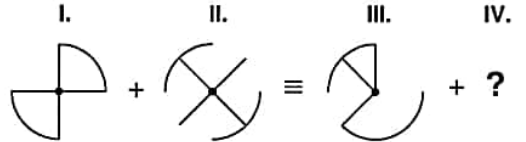

K U A R K Y A Y I N L A R I

K U A R K P U B L I C A T I O N S

YÖS

14

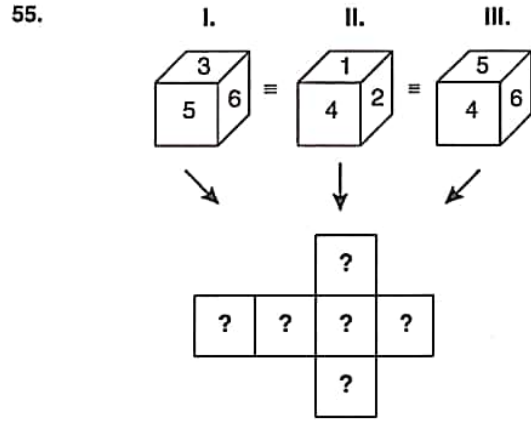
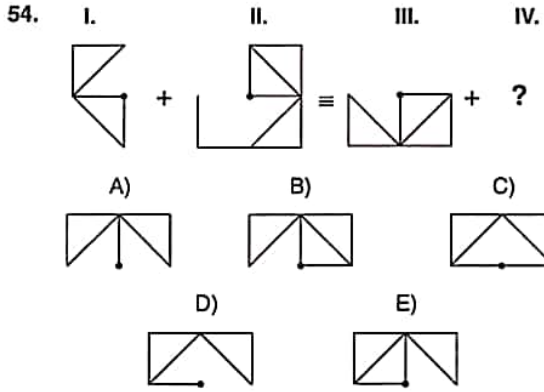

Yukarıdaki şekillerin tümü aynı küpü göstermektedir. Buna göre, aşağıdakilerden hangisi bu küpün açılmış halidir?

The figures represent the same cube above. Accordingly, which of the following represents the unfolded form of this cube?

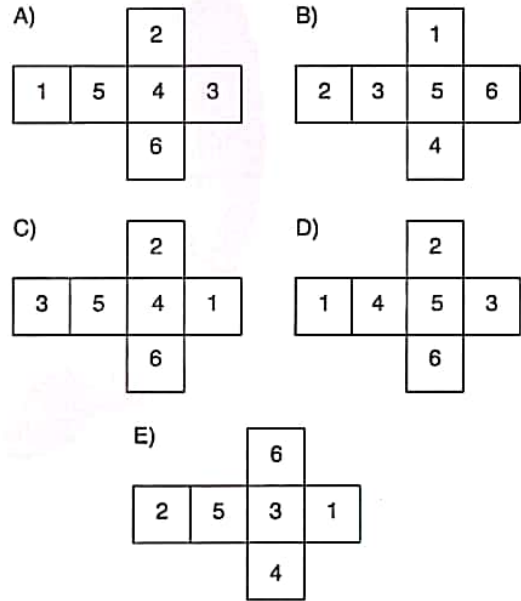

K U A R K Y A Y I N L A R I

K U A R K P U B L I C A T I O N S

YÖS

14

56.

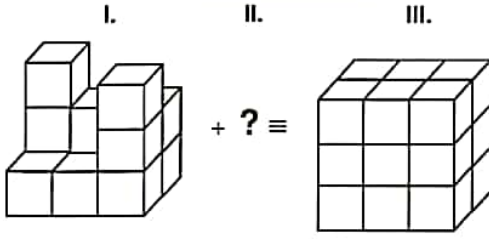

Yukarıdaki birinci satırdaki cisim aşağıdakilerden hangisiyle tamamlanırsa üçüncü satırdaki cisim elde edilir?

Which of the following shapes completes the shape in first row to the shape in the third row?

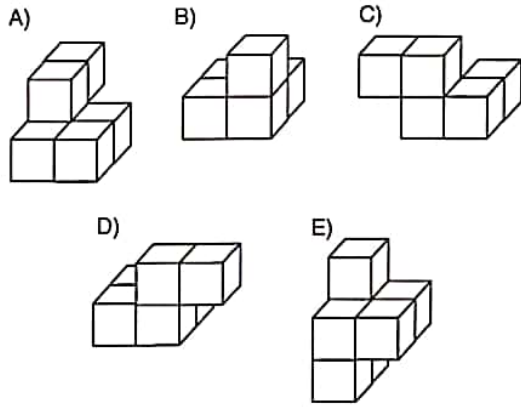

57 ve 58. soruları aşağıdaki örnekte verilen ilişkiye göre cevaplayınız.

Answer questions 57 and 58, in accordance with the relation established in the example below.

ÖRNEK / EXAMPLE:

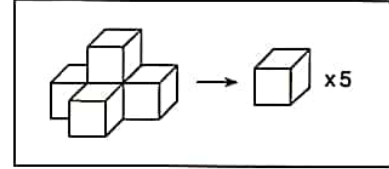

57.

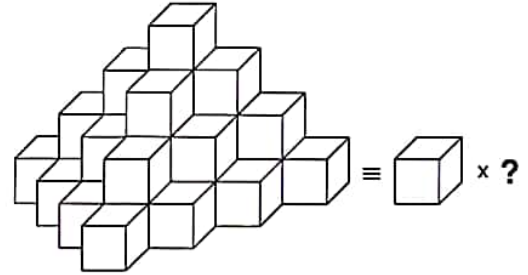

A) 29 B) 30 C) 31 D) 32 E) 33

58.

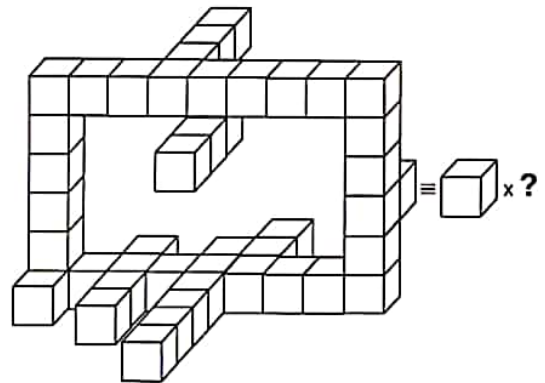

A) 43 B) 44 C) 45 D) 46 E) 47

K U A R K Y A Y I N L A R I

K U A R K P U B L I C A T I O N S

YÖS

14

59.

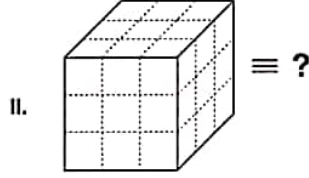
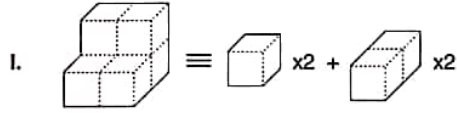

I. satırda belirlenen ilişkiye göre II. satırı hangi şeklin tamamladığını bulunuz.

Find the figure which completes row II in accordance with the relation in row I.

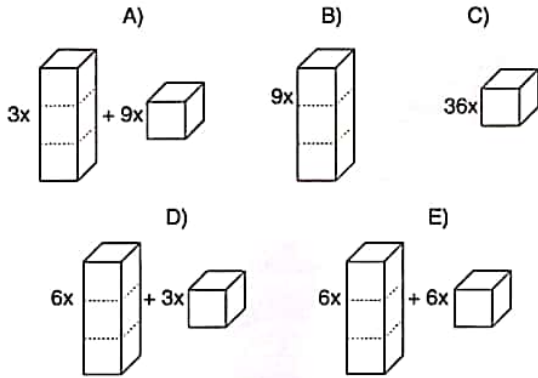

60.

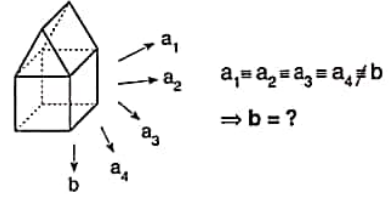

Aşağıdakilerden hangisi yukarıda verilen nesnenin açılımlarından biri değildir?

Which of the following does not represent one of the unfolded forms of the object given above?

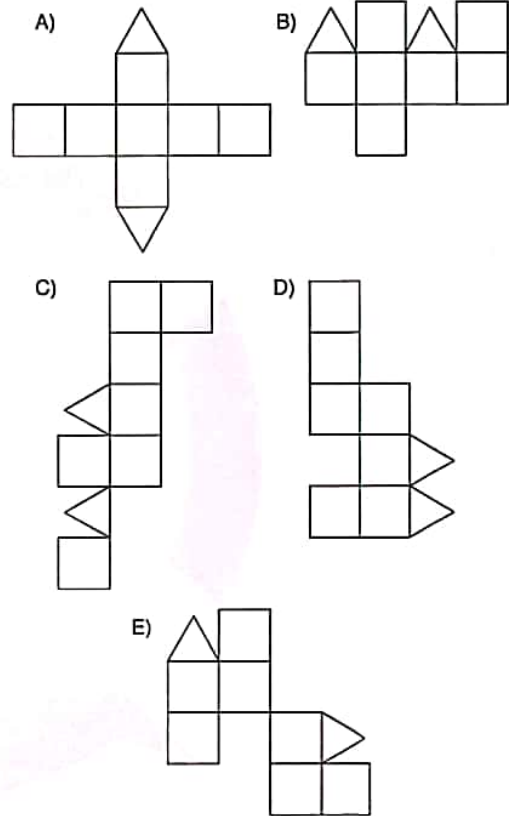

YÖS

14

61. $(11011)_2 = (x)_3 \Rightarrow x = ?$

- A) 100 B) 101 C) 1000
D) 1001 E) 1110

62. $3 - \frac{2}{1 - \frac{3}{2 - \frac{1}{2}}} = ?$

- A) 2 B) 3 C) 4 D) 5 E) 6

63. $\frac{x^2 - \frac{1}{x^2}}{x + \frac{1}{x}} \cdot \frac{x}{x-1} = ?$

- A) $\frac{1}{x+1}$ B) $\frac{1}{x-1}$ C) 11
D) $x+1$ E) $x-1$

64. $2x^2 - xy - y^2 = -4$
 $x^2 + xy - 2y^2 = -5$
 $\Rightarrow |x - y| = ?$

- A) 1 B) 2 C) 3 D) 4 E) 5

65. a, b, x, y pozitif sayılardır. Buna göre, $a \cdot b = x$, $a + b = y$ ise, $\frac{1}{a} + \frac{1}{b}$ nin x ve y cinsinden değeri nedir?

If $a \cdot b = x$ and $a + b = y$, what is the value of $\frac{1}{a} + \frac{1}{b}$ in terms of x and y when a, b, x, and y are positive integers?

- A) $\frac{y}{x}$ B) $\frac{x}{y}$ C) $\frac{x}{x+y}$
D) $\frac{y}{x+y}$ E) $\frac{x+y}{x}$

66. $(x-4)^2 = (2x+5)^2 \Rightarrow \prod x = ?$

- A) -3 B) -2 C) -1 D) 2 E) 3

K
U
A
R
K
Y
A
Y
I
N
L
A
R
IK
U
A
R
K
P
U
B
L
I
C
A
T
I
O
N
S

67. $\frac{\frac{1}{\sqrt{2}} - 2\sqrt{2}}{\frac{1}{\sqrt{2}} + \sqrt{2}} = ?$

- A) $-\sqrt{2}$ B) -1 C) $-\frac{1}{\sqrt{2}}$ D) 1 E) 2

68. $\left. \begin{array}{l} \frac{a+b}{c} = \frac{4}{3} \\ \frac{c}{b} = \frac{3}{2} \end{array} \right\} \Rightarrow \frac{a}{b} = ?$

- A) $\frac{1}{3}$ B) $\frac{1}{2}$ C) $\frac{2}{3}$ D) 1 E) 2

69. $\frac{2ax-b}{3} - \frac{2x-b}{2} = \frac{x+3}{3}$

$\text{ÇK(SS)} = R \Rightarrow a \cdot b = ?$

- A) 2 B) 4 C) 6 D) 8 E) 12

70. $\frac{\cot x - 1}{\tan x - 1} \cdot \tan x = ?$

- A) $\tan x$ B) $\cot x$ C) $-\tan x$ D) -1 E) -2

71. $f(x) = \frac{x+6}{2}$, $g(x) = \frac{x-2}{x+3} \Rightarrow (g \circ f^{-1})^{-1}(2) = ?$

- A) -4 B) -3 C) -1 D) 1 E) 3

72. $\frac{\cos 2x}{\cos x - \sin x} = \frac{4}{3} \Rightarrow \sin 2x = ?$

- A) $\frac{3}{5}$ B) $\frac{4}{5}$ C) $\frac{4}{9}$ D) $\frac{5}{9}$ E) $\frac{7}{9}$

73.

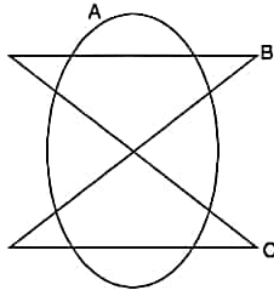

Taralı bölge / The shaded region = ?

- A) $(B \cup C) \setminus A$ B) $A \setminus (B \cup C)$ C) $(B \cap C) \setminus A$
 D) $(B \cap C) \setminus A$ E) $A \setminus (B \cap C)$

74. $5 < 12x - 15 \leq 9$

$$x \in \mathbb{Z} \Rightarrow \sum x = ?$$

- A) 30 B) 32 C) 36 D) 40 E) 48

75. $\frac{2x-3}{x^2-3x-4} = \frac{A}{x-4} + \frac{B}{x+1} \Rightarrow A \cdot B = ?$

- A) -3 B) -1 C) 1 D) 2 E) 3

76. $\frac{3x.P(2x-1)+x^2-1}{2.Q(x)-3} = 4x+1$

$$\frac{P(x+1)}{5} \Big| \frac{x+4}{K(x)} \quad \frac{Q(3x+2)}{K(x)} \Big| \frac{x+1}{K(x)} \Rightarrow K(x) = ?$$

- A) 3 B) 4 C) 5 D) 6 E) 7

77. $(m-2)x^2 - 2mx + m - 1 = 0$

$$f(x_1) = f(x_2) = 0,$$

$$x_1 < 0 < x_2 \Rightarrow ? < m < ?$$

- A) (0, 2) B) (0, 1) C) (1, 2)
 D) (1, ∞) E) (2, ∞)

78. $\left(\frac{x}{x-1}\right)^2 + \frac{7x}{1-x} + 12 = 0$

$$\text{ÇK(SS)} = \{x_1, x_2\} \Rightarrow x_1 + x_2 = ?$$

- A) $\frac{8}{3}$ B) $\frac{14}{3}$ C) $\frac{17}{6}$ D) $\frac{19}{6}$ E) $\frac{23}{6}$

YÖS

14

79. $\frac{x^3(1-x)^2}{(x-3)(x^2+9)} \leq 0 \Rightarrow \text{ÇK(SS)} = ?$

- A) [0, 1] B) [0, 3] - {1} C) [0, 3]
D) [0, 3] E) [1, 3]

80. $5^{\ln x} + x^{\ln 5} = 250 \Rightarrow \text{ÇK(SS)} = ?$

- A) 2 B) 3 C) e^2 D) e^3 E) e^5

81.

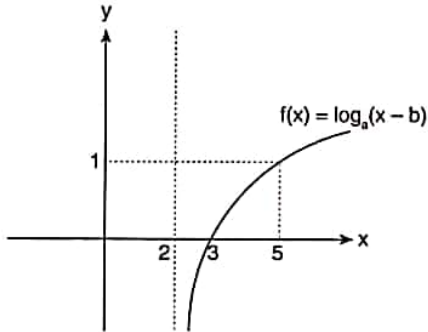

$\Rightarrow a + b = ?$

- A) -1 B) 0 C) 2 D) 3 E) 5

82. $P(x) = x^2 + 3x + 6 \Rightarrow P(-2i) = ?$

- A) $2i$ B) $6i$ C) $2 + 6i$
D) $2 - 6i$ E) $-2i$

83.

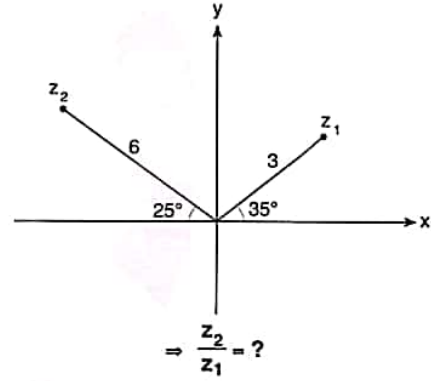

- A) $-1 - \sqrt{3}i$ B) $-1 + \sqrt{3}i$ C) $-2 - \sqrt{3}i$
D) $-2 + \sqrt{3}i$ E) $-2 + 2\sqrt{3}i$

84. $4x \cdot |x| = \text{sgn}(x) + 15 \Rightarrow \text{ÇK(SS)} = ?$

- A) $\{-2\}$ B) $\{2\}$ C) $\{-2, 2\}$
D) $\{-2, 2, -\frac{7}{2}\}$ E) \emptyset

K U A R K Y A Y I N L A R I

K U A R K P U B L I C A T I O N S

YÖS

14

$$85. \sum_{k=1}^x (2k-1) = 144 \Rightarrow x = ?$$

- A) 9 B) 10 C) 11 D) 12 E) 13

$$86. \sum_{k=1}^2 \prod_{n=0}^2 (n+k) = ?$$

- A) 30 B) 36 C) 45 D) 60 E) 90

$$87. f(x) = x \cdot (x-2)^3$$

$$\Rightarrow \lim_{h \rightarrow 0} \frac{f(4+h) - f(4)}{h} = ?$$

- A) 42 B) 48 C) 50 D) 54 E) 56

$$88. f(x) = \sqrt{5x+1} \Rightarrow f'(3) = ?$$

- A) -1 B) $\frac{5}{8}$ C) 1 D) 5 E) 8

$$89. \lim_{x \rightarrow a} \frac{x^2 - a^2}{\sin(a-x)} = ?$$

- A) -2a B) -a C) 0
D) a E) 2a

$$90. f(x) = \frac{2x^2 + 3|x-1| - 2}{|x| - 1} \Rightarrow \lim_{x \rightarrow 1^+} f(x) = ?$$

- A) -7 B) -1 C) 0
D) 1 E) 7

K
U
A
R
K
Y
A
Y
I
N
L
A
R
IK
U
A
R
K
P
U
B
L
I
C
A
T
I
O
N
S

YÖS

14

91.

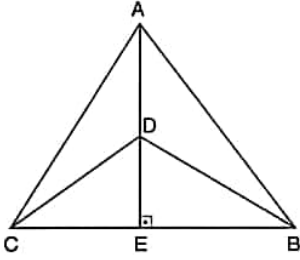

- $[AE] \perp [CB]$, $IADI = 12 \text{ br}(u)$, $IBCI = 16 \text{ br}(u)$
 \Rightarrow Taralı alan / The shaded area = ? $\text{br}^2(u^2)$
 A) 48 B) 64 C) 96 D) 144 E) 192

92.

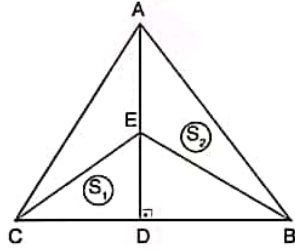

- $[AD] \perp [BC]$, $IABI = IACI = 10 \text{ br}(u)$, $IBCI = 16 \text{ br}(u)$
 $\Rightarrow S_1 + S_2 = ? \text{ br}^2(u^2)$
 A) 12 B) 18 C) 24 D) 28 E) 32

93.

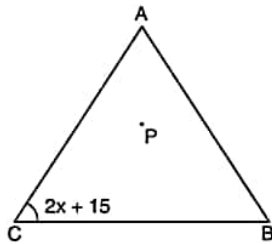

- ABC üçgende P noktası çevrel çemberin merkezidir. $x \in \mathbb{Z}$ ise $\max(x) = ?$
 The point P in the triangle above is the center of the circumscribed circle. If $x \in \mathbb{Z}$, $\max(x) = ?$
 A) 35 B) 37 C) 40 D) 42 E) 45

94.

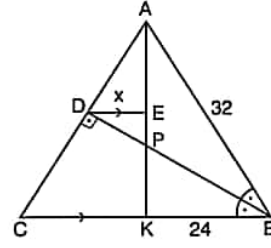

- $m(\angle ABD) = m(\angle DBC)$
 $IABI = 32 \text{ br}(u)$, $IBKI = 24 \text{ br}(u)$, $[BD] \perp [AC]$
 $\Rightarrow IDEI = x = ? \text{ br}(u)$
 A) 2 B) 4 C) 5 D) 6 E) 7

95.

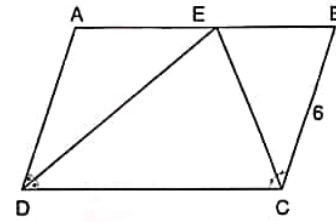

- ABCD bir paralelkenardır. / ABCD is a parallelogram.
 $m(\widehat{ADE}) = m(\widehat{EDC})$, $m(\widehat{DCE}) = m(\widehat{ECB})$, $IBCI = 6 \text{ cm}$
 \Rightarrow Çevre / The perimeter(ABCD) = ? $\text{br}(u)$
 A) 18 B) 24 C) 36 D) 42 E) 48

96.

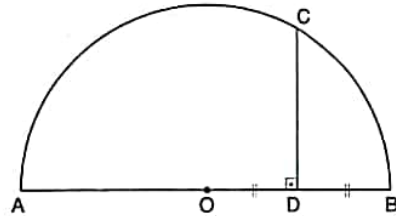

- O noktası şekildeki yarım çemberin merkezidir.
 Point O is the center of the semicircle in the figure.
 $IODI = IDBI$, $ICDI = 6\sqrt{3} \text{ cm} \Rightarrow IAOI = ? \text{ cm}$
 A) 3 B) $3\sqrt{2}$ C) 6 D) $4\sqrt{3}$ E) 12

K U A R K Y A Y I N L A R I

K U A R K P U B L I C A T I O N S

97.

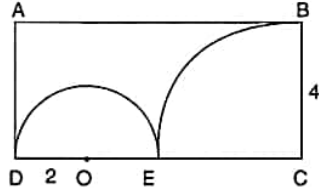

Şekildeki ABCD dikdörtgeninde C noktası çeyrek çemberin merkezi, O noktası yarım çemberin merkezidir.

ABCD is a rectangle. Point C is the center of the quadrant in the rectangle and point O is the center of the semicircle in the rectangle.

$$2 \cdot |OD| = |BC| = 4 \text{ cm} \Rightarrow TA/SA = ? \text{ br}^2(u^2)$$

- A) $32 - 6\pi$
 B) $16 - 4\pi$
 C) $48 - 6\pi$
 D) $24 - 4\pi$
 E) $36 - 6\pi$

98.

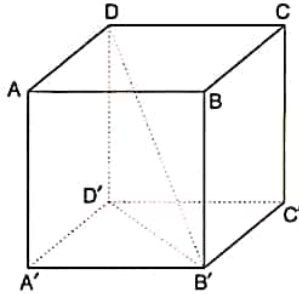

ABCD A'B'C'D' bir küptür. / ABCDA'B'C'D' is a cube.

Taralı alan / The shaded area = $6\sqrt{2} \text{ cm}^2$

$$\Rightarrow A(ABCD A'B'C'D') = ? \text{ cm}^2$$

- A) 24 B) 36 C) $36\sqrt{2}$ D) 48 E) 72

99.

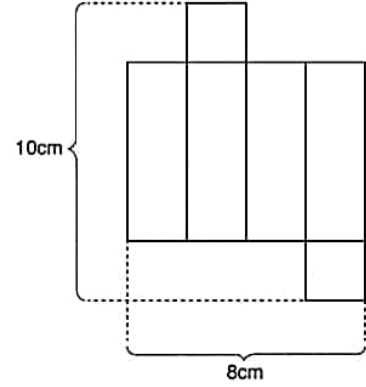

Yukarıdaki açık hali verilen kare dik prizmanın hacmi kaç cm^3 tir.

How many cm^3 is the volume of the rectangular prism which its unfolded view is given above?

- A) 16 B) 20 C) 24 D) 28 E) 32

K U A R K Y A Y I N L A R I

K U A R K P U B L I C A T I O N S

$$100. \vec{A} = \begin{bmatrix} -1 \\ 2 \end{bmatrix}, \vec{B} = \begin{bmatrix} 3 \\ -2 \end{bmatrix}$$

$$2 \cdot \vec{C} = \vec{A} - 3 \cdot \vec{B} \Rightarrow \vec{C} = ?$$

- A) $\begin{bmatrix} 5 \\ 0 \end{bmatrix}$ B) $\begin{bmatrix} 0 \\ 4 \end{bmatrix}$ C) $\begin{bmatrix} -5 \\ 2 \end{bmatrix}$ D) $\begin{bmatrix} -5 \\ 4 \end{bmatrix}$ E) $\begin{bmatrix} 5 \\ -4 \end{bmatrix}$

1, 2, 3 ve 4. sorularda I. gruptaki her bir harf, rakam veya şekil, II. gruptaki farklı birer harf, rakam veya şekil ile gösterilmiştir. Buna göre, soru işaretiyle belirtilen harfleri, rakamları veya şekilleri bulunuz.

In questions 1, 2, 3 and 4 each letter, numeral or figure in group I stand for a different letter, numeral or figure in group II. Accordingly, find the letters, numerals or figures which the questions mark stands for.

- 1.
- | I. | II. |
|-----------|-----------|
| U F S B T | 9 8 5 4 2 |
| T F Z S F | 5 8 7 9 8 |
| S F T U B | 0 2 6 8 4 |
| Z B S F U | 7 2 9 8 4 |
| H B L F U | 4 8 9 2 5 |
- ⇒ UFSBT = ?
- A) 98542 B) 58798 C) 02684
D) 72984 E) 48925

- 2.
- | I. | II. |
|-------------|-------------|
| A K M İ U D | 7 8 9 1 2 3 |
| İ U D R S N | 1 2 3 4 5 6 |
| R S N A K M | 3 4 5 6 7 8 |
| M İ U D R S | 2 3 4 5 6 7 |
| K M İ U D R | 4 5 6 7 8 9 |
- ⇒ İUDRSN = ?
- A) 789123 B) 123456 C) 345678
D) 234567 E) 456789

3.

I.	II.
9 3 2 4 5	○ ⇒ ↗ □ ⇒
5 3 7 8 9	○ + □ ↗ ▲
9 0 2 4 5	✓ ⇒ ○ + Δ
5 4 8 7 0	⇒ ⇒ ✓ + ○
2 3 5 4 6	⇒ ▲ ✓ + ○

⇒ ○ ▲ ↗ + ⇒ = ?

- A) 64387 B) 50743 C) 54276
D) 50734 E) 05643

4.

I.	II.
2 5 3 9 7	?
8 3 9 5 8	
3 4 6 8 0	
0 2 3 4 5	

- A) B Ü L U Y
O L U O Ü
B T C O M
B M L T Ü
- B) T Ü L U Y
L O U Ü Y
T B C O M
M B L T Ü
- C) B Ü L U Y
O L U Ü O
L T C O M
M B L T Ü
- D) B Ü L U Y
O L U O Ü
L T M O M
M B L T U
- E) T Ü L U Y
B L U Ü Y
B T C O M
M B L T Ü

YÖS

15

5. ●SHAKESPEARE = ERAEPSEKAHS
ADAMNABO▲ = DAMAANOB
= ●MUTLULUK▲ = ?
A) UKULTLMU
B) MUTLULUK
C) KULULTUK
D) UMLTLUKU
E) TLUMLUKU

6, 7 ve 8. sorulardaki verilen işlemlerde her harf sıfırdan ve birbirinden farklı birer rakamı göstermektedir. Buna göre, soru işareti ile belirtilen harf ya da işlemin değerini bulunuz.

In the operations which are given in questions 6, 7 and 8 each letter stands for a different non-zero numeral. Accordingly, find the value of the letter or operation indicated by the questions mark.

6.
$$\begin{array}{r} RK \\ KR \\ RR \\ + KK \\ \hline 330 \end{array} \quad \begin{array}{r} KR \\ - RK \\ \hline 9 \end{array} \Rightarrow RK = ?$$

A) 67 B) 76 C) 78 D) 87 E) 98

7.
$$\begin{array}{r} 623A \\ - 4CBA \\ \hline A640 \end{array} \Rightarrow A + B + C = ?$$

A) 12 B) 13 C) 14 D) 15 E) 16

8.
$$\begin{array}{r} KK \\ \times LK \\ \hline \bullet \bullet 9 \\ + \bullet L1 \\ \hline \bullet \bullet \bullet \bullet \end{array} \Rightarrow K + L = ?$$

- A) 8 B) 9 C) 10 D) 11 E) 12

9. I. $24 * 13 = 4$
II. $14 * 25 = 27$
III. $19 * 44 = 1$
IV. $36 * 36 = ?$

Yukarıdaki eşitliklerde * işaretinin görevi verilmiştir. Buna göre, dördüncü eşitlikteki soru işaretinin yerine aşağıdaki sayılardan hangisi gelmelidir?

In the equations above, the function of * is given. Accordingly, which of the following numbers does the question mark stand for in the fourth equation?

- A) 24 B) 27 C) 36 D) 42 E) 49

10. I. $4 \Delta 5 = 24$
II. $6 \Delta 2 = 18$
III. $7 \Delta 8 = 63$
IV. $9 \Delta 8 = ?$

Yukarıdaki eşitliklerde Δ işaretinin görevi verilmiştir. Buna göre, dördüncü eşitlikteki soru işaretinin yerine aşağıdaki sayılardan hangisi gelmelidir?

In the equations above, the function of Δ is given. Accordingly, which of the following numbers does the question mark stand for in the fourth equation?

- A) 77 B) 78 C) 79 D) 80 E) 81

K U A R K Y A Y I N L A R I

K U A R K P U B L I C A T I O N S

YÖS

15

11. I. $a * b = 2ab - 1$
 II. $a \Delta b = 3a - b^2$
 III. $(2 * 5) \Delta (3 \Delta 2) = ?$

Yukarıdaki eşitliklerde $*$ ve Δ işaretlerinin görevleri verilmiştir. Buna göre, üçüncü eşitlikteki soru işaretinin yerine aşağıdaki sayılardan hangisi gelmelidir?

In the equations above, the functions of $*$ and Δ are given. Accordingly, which of the following numbers does the question mark stand for in the third equation?

- A) 32 B) 33 C) 34 D) 35 E) 36

12. I. $a \Delta b = \begin{cases} 2a + b & , a - 2b - 1 < 0 \\ 3a - b & , a - 2b - 1 \geq 0 \end{cases}$

- II. $(5 \Delta 2) \Delta 7 = ?$

Yukarıdaki birinci eşitlikte Δ işaretinin görevi verilmiştir. Buna göre, ikinci eşitlikteki soru işaretinin yerine aşağıdaki sayılardan hangisi gelmelidir?

In the first equation above, the function of Δ is given. Accordingly, which of the following numbers does the question mark stand for in the second equation?

- A) 30 B) 31 C) 32 D) 33 E) 34

13.

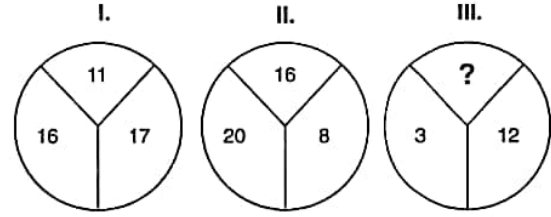

I. ve II. şekillerde verilen kurala göre, III. şekildeki soru işaretinin yerine aşağıdaki sayılardan hangisi gelmelidir?

Which of the following numbers does the question mark stand for in figure III, in accordance with the rule established in figure I and II?

- A) 25 B) 27 C) 28 D) 29 E) 30

14.

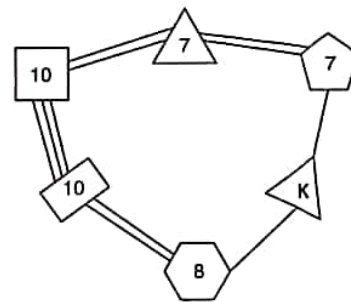

Yukarıdaki sayı-şekil ilişkisine göre K kaçtır?
 According to the number-figure relation above, what is the value of K?

- A) 3 B) 4 C) 5 D) 6 E) 8

15.

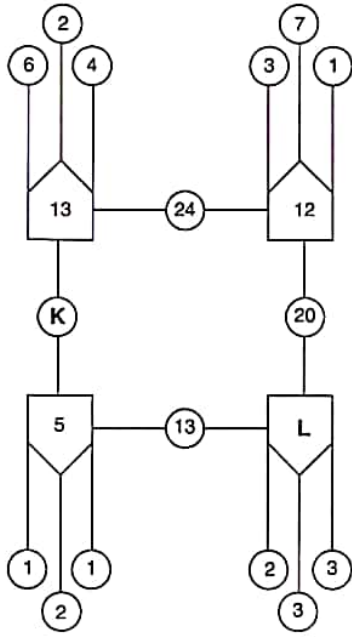

$$\Rightarrow K + L = ?$$

Yukarıdaki sayı-şekil ilişkisine göre $K + L$ kaçtır?
According to the number-figure relation above, what is the value of $K + L$?

- A) 22 B) 23 C) 24 D) 25 E) 26

16.

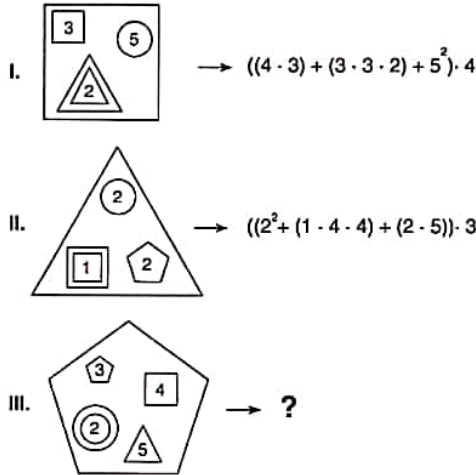

I. ve II. satırlarda belirlenen ilişkiye göre, III. satırı aşağıdaki sayılardan hangisi tamamlar?
Which of the following numbers completes III. in accordance with the relation established in I and II?

- A) 300 B) 310 C) 320 D) 330 E) 340

17.

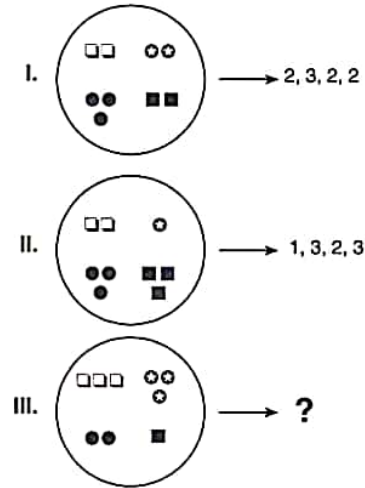

I. ve II. satırlarda belirlenen ilişkiye göre, III. satırı aşağıdaki sayılardan hangisi tamamlar?

Which of the following numbers completes III, in accordance with the relation established in I and II?

- A) 3, 2, 1, 3 B) 3, 2, 3, 1 C) 3, 3, 2, 1
D) 1, 3, 2, 3 E) 3, 3, 1, 2

18.

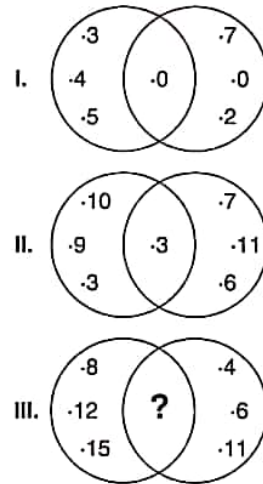

I. ve II. satırlarda belirlenen ilişkiye göre, III. satırı aşağıdaki sayılardan hangisi tamamlar?
Which of the following numbers completes III. in accordance with the relation established in I and II?

- A) 3 B) 4 C) 6 D) 8 E) 12

YÖS

15

19.

+	a	b	c
a	12		
b		2a+8	
c			3a+2

$$\Rightarrow b + c = ?$$

Yukarıdaki toplama tablosunda a, b ve c harfleri pozitif birer tam sayının yerine kullanılmıştır. Buna göre, b + c kaçtır?

In the summation table above, the letters a, b and c each stands for a positive integer. Accordingly, what is the value of b + c?

- A) 15 B) 20 C) 28 D) 30 E) 40

20.

x	a	b	c
a	b		
b	3·b		108
c			

$$\Rightarrow c = ?$$

Yukarıdaki çarpma tablosunda a, b ve c harfleri pozitif birer tam sayının yerine kullanılmıştır. Buna göre, c kaçtır?

In the multiplication table above, the letters a, b and c each stands for a positive integer. Accordingly, what is the value of c?

- A) 16 B) 14 C) 12 D) 10 E) 8

21.

+	a	b	c
a		42	
b			
c			50

x	a	b	c
a			
b			500
c			

$$\Rightarrow a = ?$$

Yukarıdaki toplama ve çarpma tablolarında a, b ve c harfleri pozitif birer tam sayının yerine kullanılmıştır. Buna göre, a kaçtır?

In the summation and multiplication tables above, the letters a, b and c each stands for a positive integer. Accordingly, what is the value of a?

- A) 18 B) 19 C) 20 D) 21 E) 22

22.

2	3	4	3
1	1	1	2
4	2	2	2
1	5	3	3
22	39	?	26

Sonuç
(Result)

Yukarıdaki tablodaki soru işaretinin yerine, aşağıdaki sayılardan hangisi gelmelidir?

Which of the following numbers does the question mark stand for in the table above?

- A) 30 B) 31 C) 32 D) 33 E) 34

K U A R K Y A Y I N L A R I

K U A R K P U B L I C A T I O N S

YÖS

15

23.

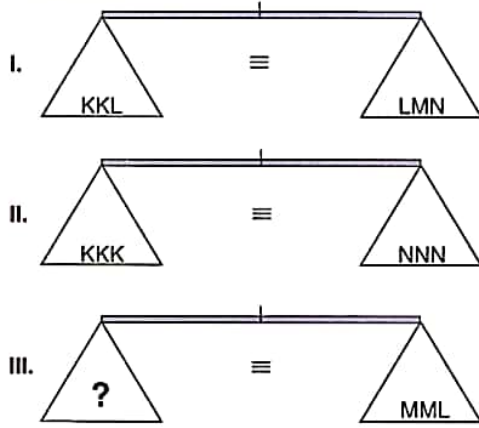

Yukarıdaki terazilerin üçü de dengededir. Buna göre, III. terazideki soru işaretini aşağıdakilerden hangisi göstermektedir?

All three scales above are in balance. Accordingly, which of the following does the question mark stand for in the third scale?

- A) KK B) LN C) NN
D) LNK E) KKLM

24.

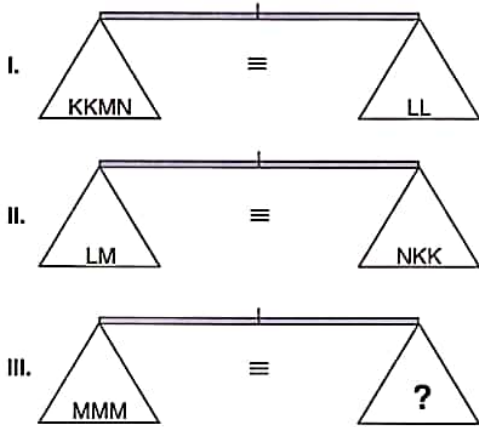

Yukarıdaki terazilerin üçü de dengededir. Buna göre, III. terazideki soru işaretini aşağıdakilerden hangisi göstermektedir?

All three scales above are in balance. Accordingly, which of the following does the question mark stand for in the third scale?

- A) LL B) KKN C) LMN
D) LKN E) MKL

25.

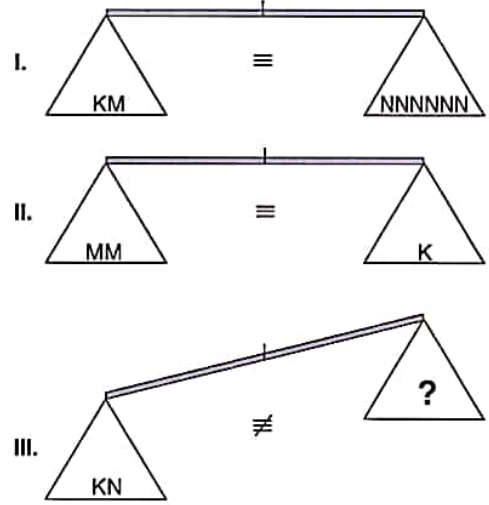

Yukarıdaki terazilerin ilk ikisi dengede olup, üçüncüsü dengede değildir. Buna göre, III. terazideki soru işaretini aşağıdakilerden hangisi göstermektedir?

First two scales above are in balance, the third scale is not in balance. Accordingly, which of the following does the question mark stand for in the third scale?

- A)KK B)NNN C)KM
D)MMM E)KKM

K U A R K Y A Y I N L A R I

K U A R K P U B L I C A T I O N S

YÖS

15

26.

I.

	X	Y	Z	T
a	3	1	4	5
b	6	3	5	2
c	3	4	1	1
d	7	5	3	1

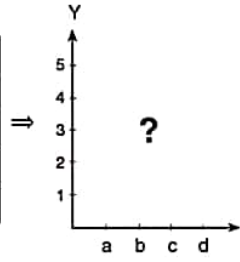

II. şekildeki çizgi grafik , I. şekildeki tabloda verilen bilgilere göre düzenlenmiştir. Buna göre II. şekildeki çizgi grafik aşağıdakilerden hangisidir?
The line graph in figure II is organised according to the information in the table in figure I. Accordingly, which of the following does the question mark stand for in the second figure?

A) Y

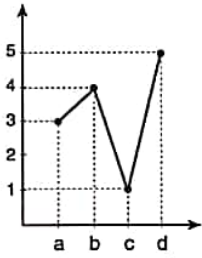

B) Y

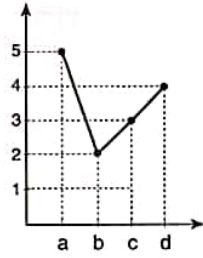

C) Y

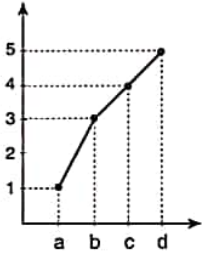

D) Y

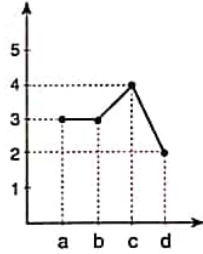

E) Y

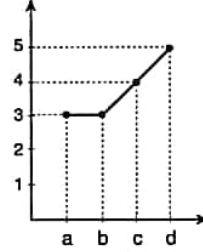

27.

I.

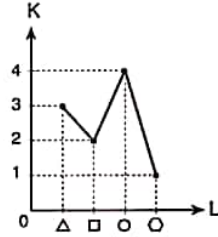

II.

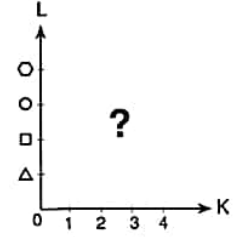

Yukarıdaki birinci çizgi grafikte verilen bilgilere göre, ikinci grafik aşağıdakilerden hangisidir?

According to the first line chart above, which of the following is the second chart?

A) L

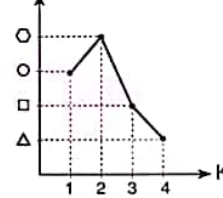

B) L

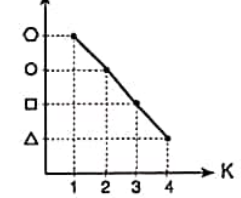

C) L

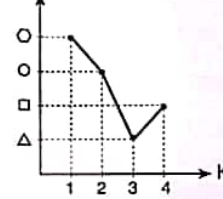

D) L

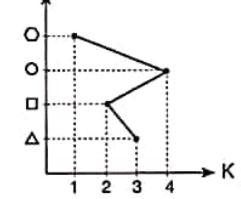

E) L

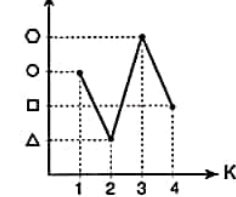

K U A R K Y A Y I N L A R I

K U A R K P U B L I C A T I O N S

28.

●	K	L	M	N	T
K	N	T	N	L	L
L	T	L	K	T	K
M	N	K	M	L	N
N	L	T	L	K	M
T	L	K	N	M	T

$$\Rightarrow ((K \bullet L) \bullet (N \bullet M)) \bullet T = ?$$

Yukarıdaki tablo ● işlemine göre düzenlenmiştir.

Buna göre, $((K \bullet L) \bullet (N \bullet M)) \bullet T$ nedir?

The table above is organized according to the ● operation. Accordingly, what is the value of $((K \bullet L) \bullet (N \bullet M)) \bullet T$?

- A) T B) N C) M D) L E) K

29.

●				
■		4		10
		16		K
				L

$$K + L = ?$$

Yukarıdaki tablo ● ve ■ işlemlerine göre düzenlenmiştir. Buna göre, $K + L$ kaçtır?

The table above are organized according to the ● and ■ operations. Accordingly, what is the value of $K + L$?

- A) 50 B) 51 C) 52 D) 53 E) 54

30.

1	1	1	1
1	2	3	4
1	3	6	10
1	4	10	20

 \Rightarrow

1	1	1
1	2	3
1	3	y
1	x	z

$$\Rightarrow x + y + z = ?$$

Yukarıda I. tabloda verilen bilgilere göre II. tablodaki

$x + y + z$ kaçtır?

According to the information given in the table I above, what is the value of $x + y + z$ in the table II?

- A) 18 B) 19 C) 20 D) 21 E) 22

31.

S	U	U	L	U
S	K	L	S	P
K	U	S	P	L

I	□	△
	△	○

$$\Rightarrow \text{○} = ?$$

I ve II yukarıdaki tablonun farklı birer parçasıdır. Buna göre, ○ aşağıdakilerden hangisidir?

I and II are different parts of the table above. Accordingly, which of the following does ○ stand for?

- A) P B) S C) L D) U E) K

32.

I	2	x	3
II	3	3	y
III	z	6	7

$$\Rightarrow x = ? ; y = ? ; z = ?$$

Yukarıdaki tabloda x , y ve z kaçtır?

In the table above, what is the value of x , y and z ?

- A) 2 ; 4 ; 4 B) 2 ; 4 ; 5 C) 3 ; 4 ; 4
D) 3 ; 5 ; 4 E) 3 ; 4 ; 5

YÖS

15

33, 34 ve 35. sorularda verilen her bir şekil matrisindeki soru işaretinin yerine hangi şeklin getirilmesi gerektiğini bulunuz.

In questions 33, 34 and 35 find the figure which should replace the question mark in each given figure matrix.

33.

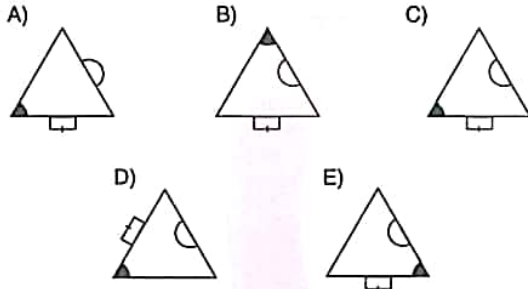
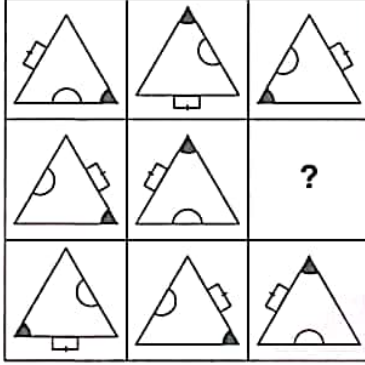

34.

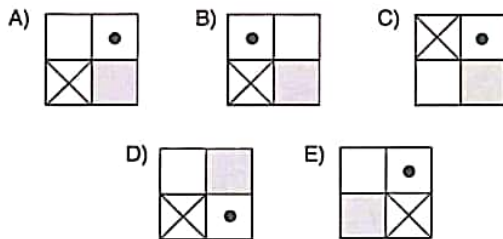
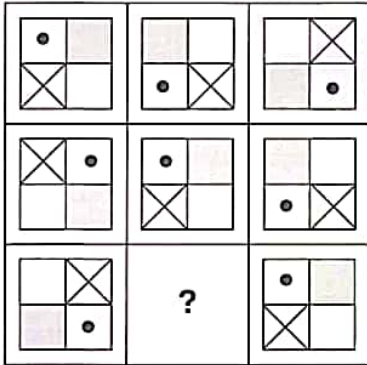

35.

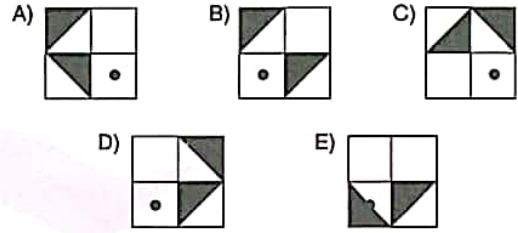
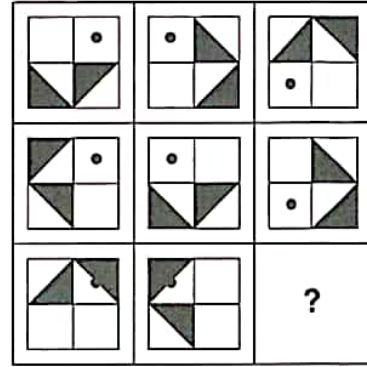

36, 37 ve 38. sorularda, verilen şekil dizisinde soru işaretinin yerine getirilmesi gereken şekli bulunuz.

In questions 36, 37 and 38 find the figure which the question mark stands for in the given figure sequence.

36.

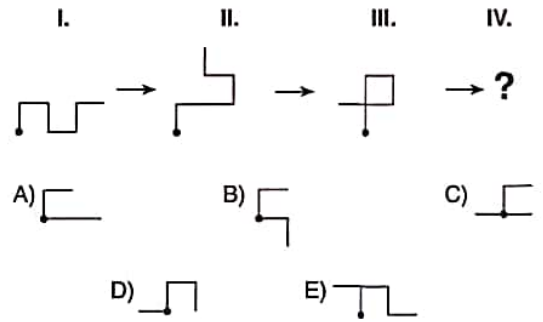

37. I. II. III. IV.

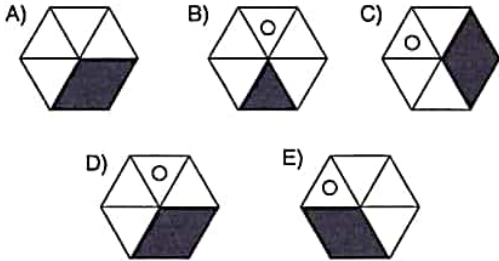
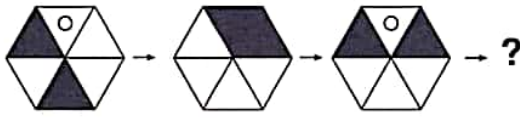

39 ve 40. sorularda, soru işaretinin yerine getirilmesi gereken şekli bulunuz.
In question 39 and 40, find the figure to replace the question mark.

39. I. II. III. IV.

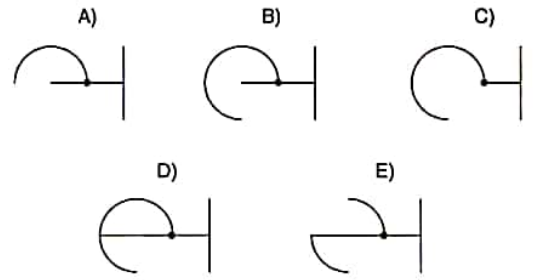
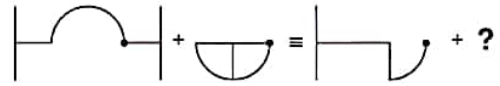

38. I. II. III. IV.

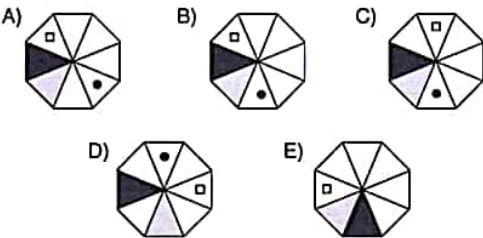
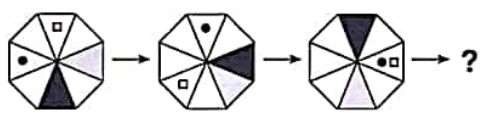

40. I. II. III. IV.

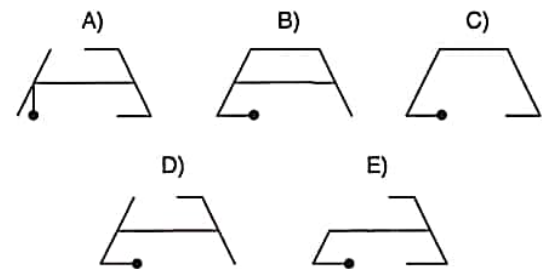
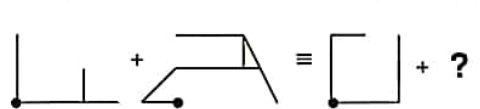

K U A R K Y A Y I N L A R I

K U A R K P U B L I C A T I O N S

YÖS

15

41 ve 42. sorularda, I. satırda belirlenen ilişkiye göre II. satırı hangi şeklin tamamladığını bulunuz.

In questions 41 and 42 find the figure which completes row II, in accordance with the relation established in row I.

41.

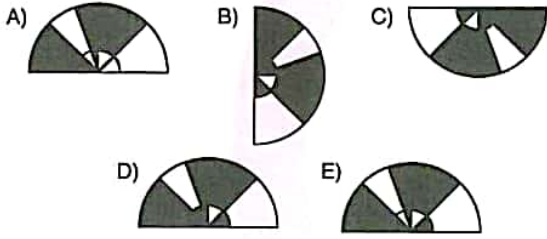
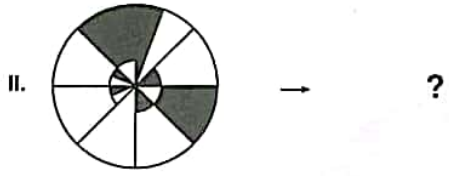
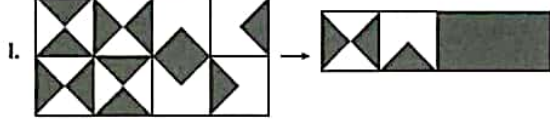

42.

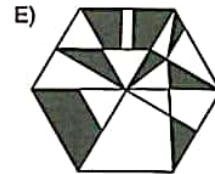
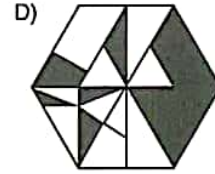
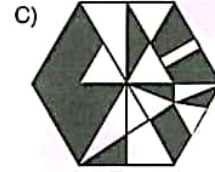
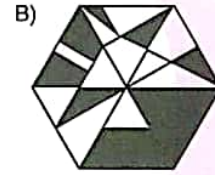
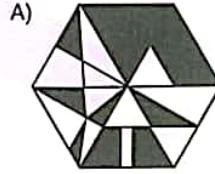
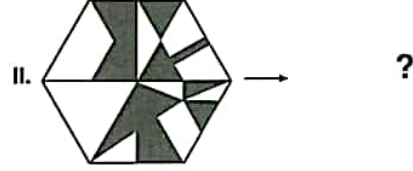
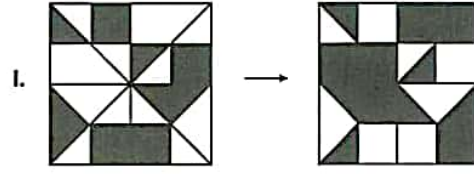

K U A R K Y A Y I N L A R I

K U A R K P U B L I C A T I O N S

YÖS

15

43, 44 ve 45. soruyu aşağıdaki örnekte verilen ilişkiye göre cevaplayınız.

Answer question 43, 44 and 45 in accordance with the relation established in the example below.

ÖRNEK / EXAMPLE:

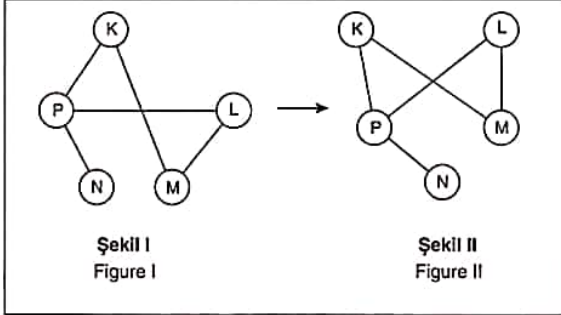

K, L, M, N ve P harfleri I. şekildeki gibi birbirine bağlanmıştır. I. şekildeki bağlantı sayıları ve birbirine bağlanan harfler değişmemek koşuluyla II. şekil elde edilmiştir.

The letters K, L, M, N and P are linked as in figure I. figure II. has been constructed so as not to change the number of links and the letters that are linked to each other in figure I.

43.

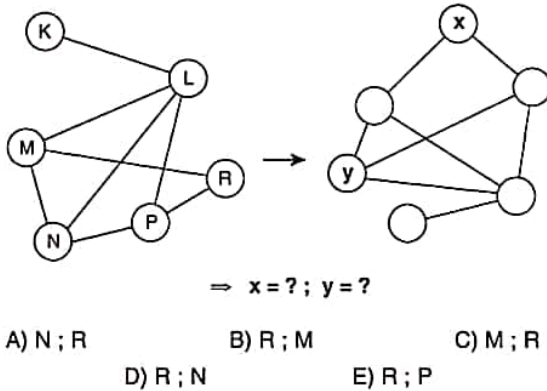

44.

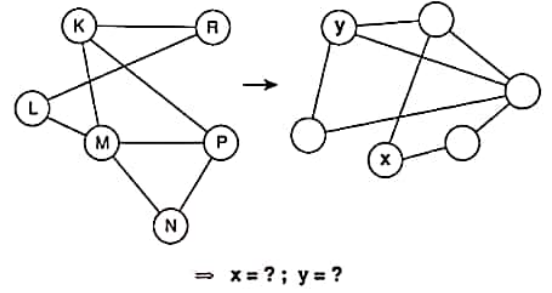

A) R ; P

B) N ; P

C) L ; P

D) R ; K

E) K ; R

45.

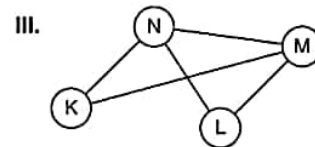
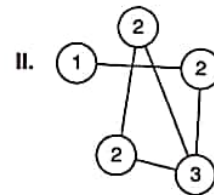
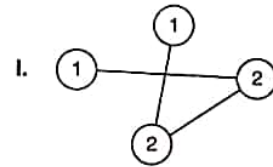

$\Rightarrow K + L + M + N = ?$

A) 10

B) 11

C) 12

D) 13

E) 14

YÖS

15

46, 47 ve 48. soruları aşağıdaki örnekte verilen ilişkiye göre cevaplayınız.

Answer questions 46, 47 and 48, in accordance with the relation established in the example below.

ÖRNEK / EXAMPLE:

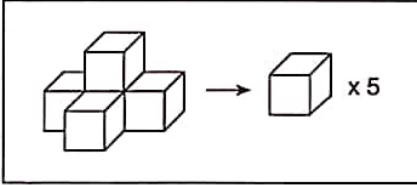

46.

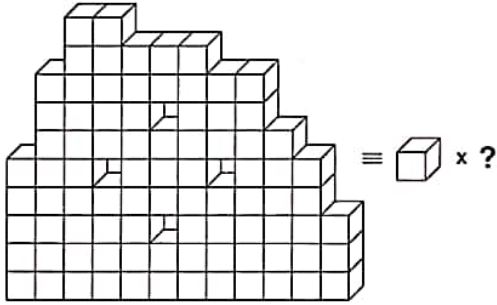

A) 86 B) 87 C) 88 D) 89 E) 90

47.

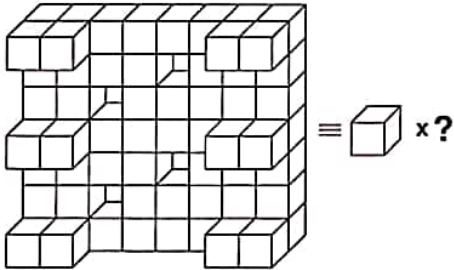

A) 70 B) 68 C) 66 D) 64 E) 62

48.

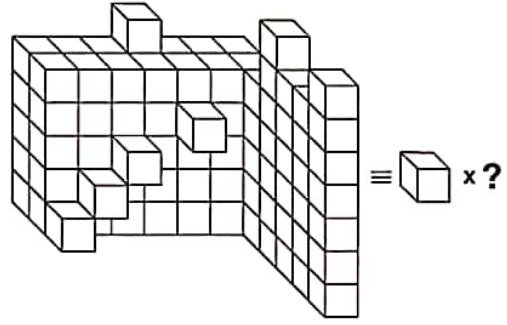

A) 103 B) 104 C) 105 D) 106 E) 107

49. soruyu aşağıdaki örnekte verilen ilişkiye göre cevaplayınız.

Answer question 49, in accordance with the relation established in the example below.

ÖRNEK / EXAMPLE:

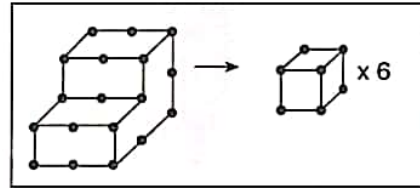

49.

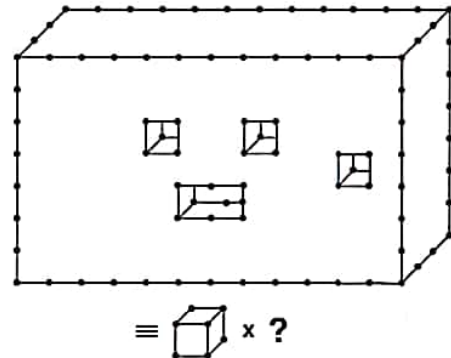

A) 243 B) 244 C) 245 D) 246 E) 247

K U A R K Y A Y I N L A R I

K U A R K P U B L I C A T I O N S

50.

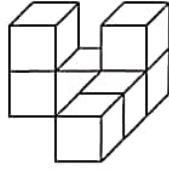

Yukarıdaki şekil bir küpe tamamlamak için en az kaç küp gereklidir?

At least how many squares are needed in order to complete the figure above to a complete square?

- A) 17 B) 18 C) 19 D) 20 E) 21

51 ve 52. soruları aşağıdaki bilgilere göre cevaplayınız.
Answer the questions 51 and 52 according to information below.

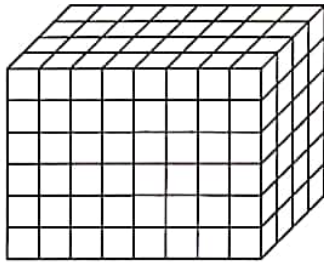

Yukarıdaki şekil birbirine eş küplerden oluşmuştur.
Oluşan şeklin bütün yüzeyleri yeşile boyanmıştır.
Buna göre;

Figure above forms from equal sized cubes.
All surfaces of this shape are painted green.
Accordingly;

51. Sadece bir yüzü boyalı kaç tane küp vardır?
How many cubes have only one painted surface?
A) 80 B) 82 C) 84 D) 86 E) 88

52. Boyasız kaç tane küp vardır?

How many cubes have no painted surface?

- A) 46 B) 48 C) 50 D) 52 E) 54

K
U
A
R
K
Y
A
Y
I
N
L
A
R
IK
U
A
R
K
P
U
B
L
I
C
A
T
I
O
N
S

53.

			1	
2			x	5
			3	

x = ?

sorudaki tablolarda, 1, 2, 3, 4 ve 5 sayıları her satırda ve sütunda birer kez olacak şekilde yerleştirilecektir.

The numbers 1, 2, 3, 4 and 5 are placed in each lines and columns only once.

- A) 3 B) 4 C) 5 D) 1 E) 2

YÖS

15

Şekilde verilen 5 x 5 kareye 1'den 25'e kadar sayılar birer kez kullanılarak yerleştirildiğinde her satırın ve köşegenlerin ve sütunun toplamları eşittir.

When the numbers from 1 to 25 are placed into the square with 5 x 5 in the figure given by each number being used once, sum of every line and column is equal.

54.

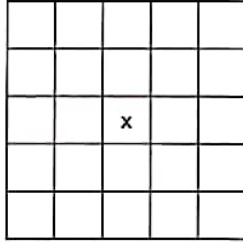

x = ?

- A) 11 B) 12 C) 13 D) 14 E) 15

55.

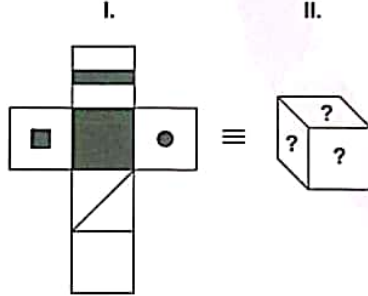

Aşağıdakilerden hangisi I. şekildeki küpün kapalı halidir?

Which of the following figures corresponds the closed form of the cube in figure I above?

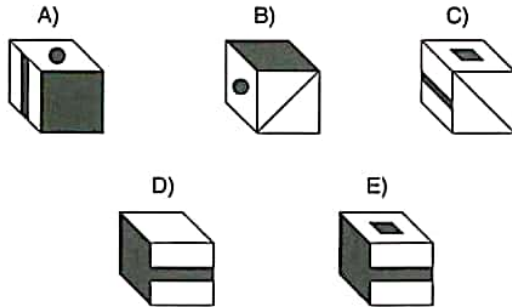

56.

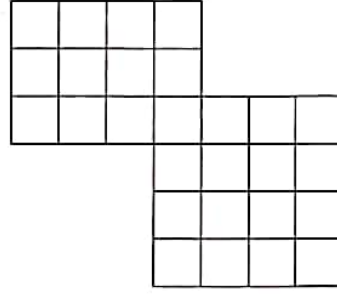

Yukarıdaki şekilde kaç kare vardır?

How many squares exist in the figure above?

- A) 48 B) 49 C) 50 D) 51 E) 52

57.

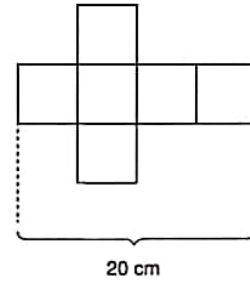

Yukarıda açılımı verilen küp kapatıldığında oluşan şeklin alanı kaç br^2 dir?

How many u^2 is the area of the figure which its unfolded view is given above when folded?

- A) 100 B) 110 C) 120 D) 125 E) 150

K U A R K Y A Y I N L A R I

K U A R K P U B L I C A T I O N S

YÖS

15

58. $\frac{A_1}{3} \quad \frac{A_2}{8} \quad \frac{A_3}{13} \dots \frac{A_{24}}{?}$

Yukarıda verilen sayı dizisinde soru işaretinin yerine getirilmesi gereken sayıyı bulunuz.

Find the number which the question mark stands for in the given number sequence.

- A) 112 B) 114 C) 116 D) 118 E) 120

59. Aşağıdakilerden hangisi belirgin bir özelliği ile diğerlerinden farklıdır?

Which of the following is different from the others according to a specific property?

- A) $\binom{14}{5}$ B) $\binom{26}{8}$ C) $\binom{12}{3}$ D) $\binom{16}{7}$ E) $\binom{35}{15}$

60.

I.



II.

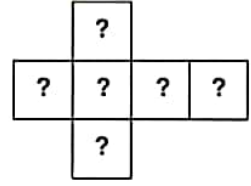

Aşağıdakilerden hangisi I. şekildeki küpün açık halidir?

Which of the following corresponds the unfolded form of the cube in figure I above?

A)

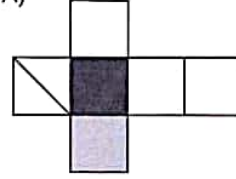

B)

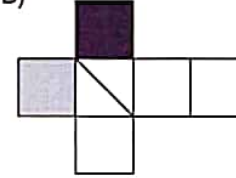

C)

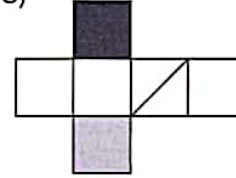

D)

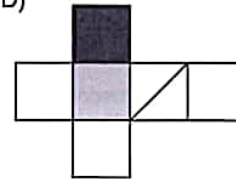

E)

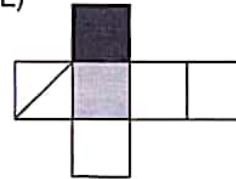

K U A R K Y A Y I N L A R I

K U A R K P U B L I C A T I O N S

YÖS

15

61. $\left[16:2-\left(\frac{1}{2}\right)^{-1}\right]:2-3=?$

- A) -1 B) 0 C) 1 D) 2 E) 3

62. $(-5)^0 \cdot (-2) - 1 + 4 : (-1) + 24 : 3 = ?$

- A) -2 B) -1 C) 0 D) 1 E) 2

63. $AB \in \mathbb{N}$,

$$\frac{AB}{2} \left| \frac{A}{11} \right. \Rightarrow \min(AB) = ?$$

- A) 13 B) 24 C) 35 D) 46 E) 57

64. Bir ölçme kabındaki karışımda $\frac{1}{5}$ oranında portakal suyu vardır. Bu karışıma aynı miktarda %20'si portakal suyu olan bir karışım ekleniyor. Son karışımın portakal suyu oranı kaçtır?

1/5 of a mixture in a measuring cup is orange juice same amount of mixture which includes %20 of orange juice is added to the measuring cup. What fraction of the final mixture is orange juice?

- A) $\frac{1}{2}$ B) $\frac{1}{3}$ C) $\frac{1}{4}$ D) $\frac{1}{5}$ E) $\frac{1}{6}$

65. $x, y \in \mathbb{Z}^-$,

$$\frac{x^2 - 3xy}{y^2} = 4 \Rightarrow \frac{x}{y} = ?$$

- A) $-\frac{1}{2}$ B) -1 C) -4 D) $\frac{1}{2}$ E) 4

66. $x = \sqrt[3]{5} - \sqrt[3]{3}$, $y = \sqrt[3]{5} + \sqrt[3]{3}$

$$A = x^3 + 3x^2y + 3xy^2 + y^3 \Rightarrow A = ?$$

- A) 20 B) 27 C) 35 D) 40 E) 42

K
U
A
R
K
Y
A
Y
I
N
L
A
R
IK
U
A
R
K
P
U
B
L
I
C
A
T
I
O
N
S

YÖS

15

67. $x \in \mathbb{Z}$,
 $3 \cdot x^x - x^x + x^{x+1} = 16 \Rightarrow x = ?$
 A) 1 B) 2 C) 3 D) 4 E) 5

68. $5^{1-\frac{1}{x}} = 15 \Rightarrow 3^x = ?$
 A) $\frac{1}{5}$ B) $\frac{1}{3}$ C) 1 D) 3 E) 5

69. $\frac{2\sqrt{18} + \sqrt{50} + \sqrt{363}}{\sqrt{10} + \sqrt{15}} = ?$
 A) 1 B) $\frac{\sqrt{2} + \sqrt{3}}{\sqrt{5}}$ C) $\frac{11\sqrt{5}}{5}$
 D) $\frac{11\sqrt{5}}{3}$ E) $\sqrt{3} - \sqrt{2}$

70. $A = \frac{\sqrt{5}-3}{3} \Rightarrow A \cdot (A+2) = ?$

- A) $-\frac{2}{3}$ B) $-\frac{4}{9}$ C) 1 D) $\frac{2}{3}$ E) $\frac{4}{9}$

71.

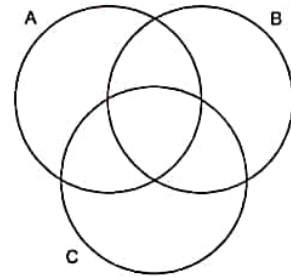

Taralı bölge / The shaded region = ?

- A) $(A \cup C) \setminus B$ B) $(A \cap B) \setminus C$ C) $(B \cap C) \setminus A$
 D) $(A \cap B \cap C) \setminus A$ E) $(B \cup C) \setminus A$

72. $\frac{x-y}{x+y} = \frac{1}{2}$,

$x \cdot y = 27 \Rightarrow \prod y = ?$

- A) -9 B) -4 C) 0 D) 4 E) 9

K
U
A
R
K
Y
A
Y
I
N
L
A
R
IK
U
A
R
K
P
U
B
L
I
C
A
T
I
O
N
S

YÖS

15

73. $|x-2|=4$, $\text{ÇK(SS)} = \{x_1, x_2\}$, $x_1 > x_2 \Rightarrow \frac{x_1}{x_2} = ?$

- A) -2 B) -3 C) 0 D) 2 E) 3

75. $f(3) = 4 \Rightarrow f(6) = ?$

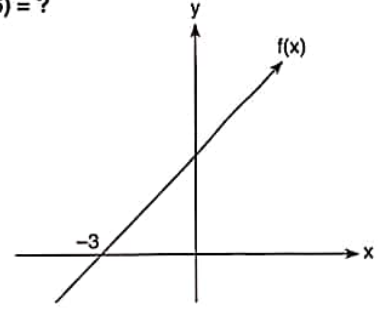

- A) 2 B) 4 C) 6 D) 8 E) 10

K U A R K Y A Y I N L A R I

K U A R K P U B L I C A T I O N S

74. $f(x) = 2x \Rightarrow f(-2x) = ?$

- A) $-2 \cdot f(x)$ B) $-f(x)$ C) $\frac{-f(x)}{2}$
D) $f(x)$ E) $2 \cdot f(x)$

76. $P(x) = x^3 - (a+1)x^2 - x + 1$

$Q(x) = -2x^4 - (b-1)x + 3$

$P(x) \cdot Q(x) = -2x^7 + \dots + 4x^4 + \dots + 3x^2 + \dots$

$\Rightarrow a + b = ?$

- A) -5 B) -6 C) -7 D) -8 E) -9

YÖS

15

77. $a = \log_{\frac{1}{5}} 25 + \log_3 27$

$b = \log 100 + \log_{32} 16 \Rightarrow \log_b a = ?$

- A) $-\frac{1}{4}$ B) $-\frac{1}{2}$ C) -1 D) 0 E) 2

79. Bir torbada 4 kırmızı, 5 beyaz top vardır. Bu torbadan aynı anda 2 top alınıyor. Alınan topların farklı renkte olma olasılığı kaçtır?

There are 4 red, 5 white balls in a pouch. What is the probability of picking different coloured balls when two balls are picked at the same time?

- A) $\frac{2}{9}$ B) $\frac{1}{3}$ C) $\frac{4}{9}$ D) $\frac{5}{9}$ E) $\frac{7}{9}$

80.

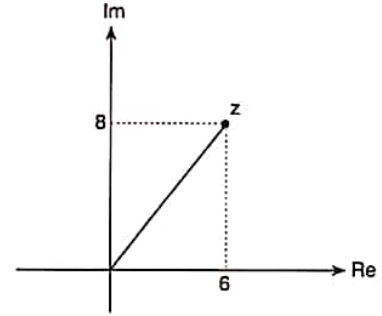

$\Rightarrow |z| = ?$

- A) 10 B) -10 C) $6 - 8i$
D) $6 + 8i$ E) 12

78. $\log_3 4 \cdot \log_4 5 \cdot \log_5 6 \cdot \dots \cdot \log_{80} 81 = A \Rightarrow A = ?$

- A) 0 B) 1 C) 2 D) 3 E) 4

81. $\left. \begin{array}{l} a = \sin x \\ b = \cos x \end{array} \right\} \Rightarrow \frac{a \cdot b}{2} = ?$

- A) $\sin x \cdot \cos x$ B) $\frac{\cos 2x}{2}$ C) $\frac{\sin 2x}{4}$
D) $\sin 2x$ E) $2 \cdot \sin 2x$

K U A R K Y A Y I N L A R I

K U A R K P U B L I C A T I O N S

YÖS

15

82. $\frac{\pi}{2} < x < \pi$, $\sin x = \frac{5}{13} \Rightarrow \cos x = ?$

- A) $-\frac{5}{13}$ B) $-\frac{12}{13}$ C) $-\frac{13}{12}$ D) $\frac{5}{13}$ E) $\frac{12}{13}$

85. $f(x) = x^2 - \frac{1}{x} + 1 \Rightarrow f'(-1) = ?$

- A) -2 B) -1 C) 0 D) 1 E) 2

K
U
A
R
K
Y
A
Y
I
N
L
A
R
I

83. $f(2) = 6 \Rightarrow \lim_{x \rightarrow 2} \frac{f(x)+4}{f(x)-1} = ?$

- A) 1 B) 2 C) 3 D) 4 E) 5

K
U
A
R
K
P
U
B
L
I
C
A
T
I
O
N
S

84. $\lim_{x \rightarrow \infty} \frac{ax^4 + 3x^2 - 1}{2x^4 + 2x^3 - x + 1} = 3 \Rightarrow a = ?$

- A) 0 B) 2 C) 4 D) 6 E) 9

86. $f(x) = \cos 2x \Rightarrow \frac{f'(x)}{\sin x} = ?$

- A) $-4\cos x$ B) $-2\cos x$ C) $-2\sin x$
D) $4\cos x$ E) $4\sin x$

YÖS

15

87. $\int \frac{1}{e^x} dx = ?$

- A) $-\frac{1}{e^x} + c$ B) $-e^x + c$ C) $-\frac{1}{e^{2x}} + c$
 D) $-e^{2x} + c$ E) $e^{2x} + c$

88. $\int_{\pi/2}^{\pi} 2x \cdot \cos t \, dt = ?$

- A) $-4x$ B) $-2x$ C) 0
 D) $2x$ E) $4x$

89. $A = \begin{bmatrix} 2 & -1 \\ 6 & 12 \end{bmatrix}, B = \begin{bmatrix} 0 & -4 \\ 8 & 10 \end{bmatrix}, A - 2B = \begin{bmatrix} x & y \\ z & t \end{bmatrix}$

- $\Rightarrow x + y + z + t = ?$
 A) -6 B) -7 C) -8 D) -9 E) -10

90. $x = \begin{bmatrix} 2 & -2 \\ 3 & -3 \end{bmatrix} \Rightarrow x^2 + 1 = ?$

- A) $\begin{bmatrix} -1 & 2 \\ 4 & -3 \end{bmatrix}$ B) $\begin{bmatrix} -1 & 2 \\ 3 & -4 \end{bmatrix}$ C) $\begin{bmatrix} -2 & 1 \\ 3 & 4 \end{bmatrix}$
 D) $\begin{bmatrix} -2 & 0 \\ -1 & 3 \end{bmatrix}$ E) $\begin{bmatrix} -1 & 2 \\ -3 & 4 \end{bmatrix}$

91. a_n bir aritmetik dizidir / a_n is an arithmetic sequence .

$$\left. \begin{array}{l} a_2 = 8 \\ a_6 = 44 \end{array} \right\} \Rightarrow a_{20} = ?$$

- A) 160 B) 164 C) 168 D) 170 E) 172

92. $1 < x < 3$

$$\Rightarrow \sum_{n=1}^{\infty} \left(\frac{2+x^n}{3^n} \right) = ?$$

- A) $\frac{x+3}{x-3}$ B) $\frac{3}{x-3}$ C) $\frac{3}{3-x}$ D) $\frac{x+1}{x-1}$ E) $\frac{x-3}{x}$

K
U
A
R
K
Y
A
Y
I
N
L
A
R
IK
U
A
R
K
P
U
B
L
I
C
A
T
I
O
N
S

YÖS

15

$$93. f(x) = \begin{cases} x^2 + 2, & x < 2 \\ ax + b, & x = 2 \\ ax^2 + 2, & x > 2 \end{cases}$$

$\forall x \in \mathbb{R}$ için $f(x)$ sürekli ise $a + b = ?$

If $f(x)$ is continuous for $\forall x \in \mathbb{R}$, $a + b = ?$

- A) $\frac{1}{2}$ B) 2 C) 3 D) 5 E) 8

95.

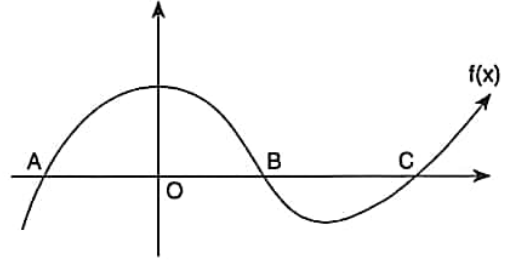

$$|AO| = |OB|, \quad f(x) = x^3 - 6x^2 + 3x + k$$

$$\Rightarrow k = ?$$

- A) -18 B) -17 C) -16 D) -15 E) -14

K
U
A
R
K
Y
A
Y
I
N
L
A
R
IK
U
A
R
K
P
U
B
L
I
C
A
T
I
O
N
S

$$94. \frac{\sin 20 + \sin 40}{1 + \cos 20 + \cos 40} = ?$$

- A) 1 B) $\tan 20$ C) $\cot 20$ D) $\frac{1}{2}$ E) $\tan 30$

96. $|AB| = |BC| = |AC|,$

$$|AD| = |AF|,$$

$$[AE] \perp [BC]$$

$$\Rightarrow m(\widehat{AFD}) = ?$$

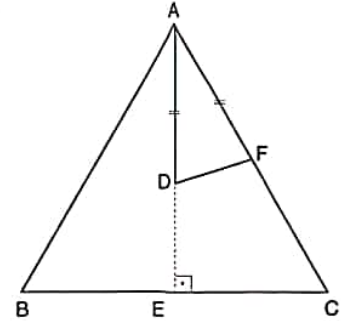

- A) 15° B) 30° C) 45°
D) 60° E) 75°

YÖS

15

97.

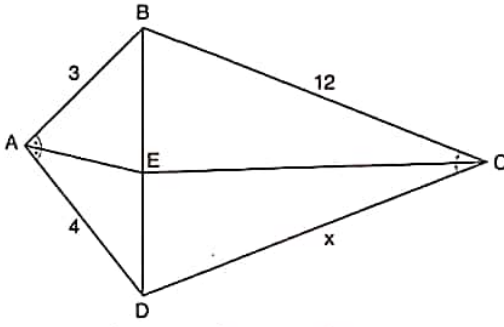

$$m(\widehat{BAE}) = m(\widehat{EAD}), m(\widehat{BCE}) = m(\widehat{ECD}),$$

$$|AB| = 3 \text{ cm}, |AD| = 4 \text{ cm}, |BC| = 12 \text{ cm}$$

$$\Rightarrow |DC| = x = ? \text{ cm}$$

- A) 9 B) 12 C) 16 D) 18 E) 24

99.

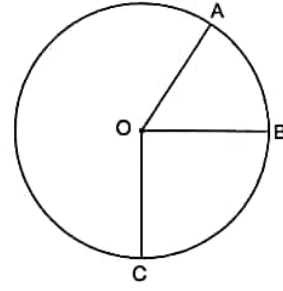

O noktası şekildeki çemberin merkezidir.

Point O is the center of the circle in the figure.

$$m(\widehat{BC}) = 2 \cdot m(\widehat{AB}), m(\widehat{AOB}) = 40^\circ \Rightarrow m(\widehat{BOC}) = ?$$

- A) 40° B) 60° C) 80° D) 90° E) 100°

98. $|AE| = |ED| = |DC|,$

$$|BF| = |FK| = |KL| = |LC|,$$

$$A(\widehat{ABC}) = 40 \text{ br}^2(u^2)$$

$$\Rightarrow TA/SA = ? \text{ br}^2(u^2)$$

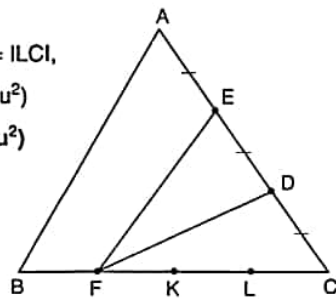

- A) 5 B) 10 C) 15 D) 20 E) 25

100. G noktası ağırlık merkezidir.

G is center of gravity.

$$A(10, 8), K(4, 5),$$

$$G(a, b)$$

$$\Rightarrow a + b = ?$$

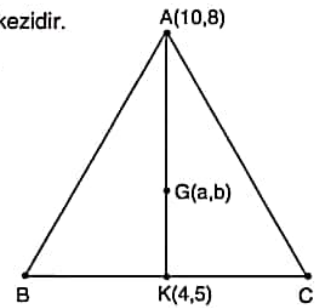

- A) 10 B) 11 C) 12 D) 13 E) 14

CEVAP ANAHTARLARI / ANSWER KEYS

Deneme 1	1	2	3	4	5	6	7	8	9	10	11	12	13	14	15	16
	A	B	B	A	D	B	B	C	A	A	A	C	A	B	D	C
	17	18	19	20	21	22	23	24	25	26	27	28	29	30	31	32
	B	C	A	A	B	E	C	A	C	A	C	B	C	C	E	B
	33	34	35	36	37	38	39	40	41	42	43	44	45	46	47	48
	A	D	E	C	C	B	C	D	B	C	E	B	C	A	D	B
	49	50	51	52	53	54	55	56	57	58	59	60	61	62	63	64
	D	B	E	B	A	E	E	D	E	D	E	D	A	E	E	D
	65	66	67	68	69	70	71	72	73	74	75	76	77	78	79	80
C	A	C	B	E	C	A	D	E	D	E	C	D	E	E	C	

Deneme 2	1	2	3	4	5	6	7	8	9	10	11	12	13	14	15	16
	A	E	B	D	A	C	C	E	C	D	A	D	C	A	B	B
	17	18	19	20	21	22	23	24	25	26	27	28	29	30	31	32
	C	C	E	A	E	E	D	D	B	C	B	C	D	A	E	E
	33	34	35	36	37	38	39	40	41	42	43	44	45	46	47	48
	C	C	B	D	A	C	B	D	C	D	B	D	D	C	E	C
	49	50	51	52	53	54	55	56	57	58	59	60	61	62	63	64
	A	A	C	C	A	A	C	B	B	A	D	E	C	D	B	E
	65	66	67	68	69	70	71	72	73	74	75	76	77	78	79	80
D	C	C	B	C	D	B	E	C	E	B	B	B	C	D	C	

Deneme 3	1	2	3	4	5	6	7	8	9	10	11	12	13	14	15	16
	C	D	C	A	E	C	D	D	C	D	A	A	E	C	C	B
	17	18	19	20	21	22	23	24	25	26	27	28	29	30	31	32
	D	D	E	B	D	B	D	E	E	D	C	D	D	D	E	C
	33	34	35	36	37	38	39	40	41	42	43	44	45	46	47	48
	B	A	A	D	D	E	A	E	E	B	D	B	D	C	C	A
	49	50	51	52	53	54	55	56	57	58	59	60	61	62	63	64
	D	E	C	A	B	C	D	E	C	C	D	B	A	D	D	D
	65	66	67	68	69	70	71	72	73	74	75	76	77	78	79	80
E	D	D	E	C	E	D	C	E	B	A	C	B	B	E	E	

Deneme 4	1	2	3	4	5	6	7	8	9	10	11	12	13	14	15	16
	C	A	D	D	D	A	C	D	E	E	C	E	E	B	C	E
	17	18	19	20	21	22	23	24	25	26	27	28	29	30	31	32
	B	A	E	D	C	B	D	C	A	E	C	C	C	A	D	B
	33	34	35	36	37	38	39	40	41	42	43	44	45	46	47	48
	C	C	C	C	E	B	D	C	B	A	E	B	C	D	E	C
	49	50	51	52	53	54	55	56	57	58	59	60	61	62	63	64
	D	C	C	A	E	B	A	D	A	C	D	D	C	E	B	E
	65	66	67	68	69	70	71	72	73	74	75	76	77	78	79	80
E	C	A	A	B	E	C	A	A	B	C	D	D	D	A	C	

CEVAP ANAHTARLARI / ANSWER KEYS

Deneme 5	1	2	3	4	5	6	7	8	9	10	11	12	13	14	15	16
	E	E	C	B	C	C	D	C	A	B	A	D	B	E	A	E
	17	18	19	20	21	22	23	24	25	26	27	28	29	30	31	32
	A	D	A	C	E	D	D	C	C	D	B	C	C	C	E	D
	33	34	35	36	37	38	39	40	41	42	43	44	45	46	47	48
	E	C	D	E	B	B	C	E	A	D	C	D	E	D	E	C
	49	50	51	52	53	54	55	56	57	58	59	60	61	62	63	64
	E	E	D	C	C	E	D	D	E	C	C	D	D	D	E	E
65	66	67	68	69	70	71	72	73	74	75	76	77	78	79	80	
C	B	E	E	A	B	B	E	A	A	B	C	B	D	B	D	

Deneme 6	1	2	3	4	5	6	7	8	9	10	11	12	13	14	15	16
	B	C	D	A	C	D	A	C	D	B	E	D	C	E	A	A
	17	18	19	20	21	22	23	24	25	26	27	28	29	30	31	32
	C	C	D	B	E	C	A	C	D	A	E	E	A	B	E	D
	33	34	35	36	37	38	39	40	41	42	43	44	45	46	47	48
	C	D	C	C	E	A	C	C	D	D	D	A	B	C	B	E
	49	50	51	52	53	54	55	56	57	58	59	60	61	62	63	64
	C	A	B	E	E	A	A	B	C	B	A	C	C	E	D	E
65	66	67	68	69	70	71	72	73	74	75	76	77	78	79	80	
A	A	A	B	E	D	E	B	A	B	A	D	C	C	B	B	

Deneme 7	1	2	3	4	5	6	7	8	9	10	11	12	13	14	15	16
	B	C	A	C	C	D	B	B	B	C	A	D	C	C	A	A
	17	18	19	20	21	22	23	24	25	26	27	28	29	30	31	32
	D	C	C	A	E	B	B	D	D	C	C	C	E	E	B	E
	33	34	35	36	37	38	39	40	41	42	43	44	45	46	47	48
	C	D	C	B	E	E	D	D	E	C	E	E	C	D	B	D
	49	50	51	52	53	54	55	56	57	58	59	60	61	62	63	64
	E	C	C	A	C	D	D	B	A	D	B	D	B	B	A	E
65	66	67	68	69	70	71	72	73	74	75	76	77	78	79	80	
B	C	D	C	E	C	D	A	B	A	A	D	D	A	B	B	

Deneme 8	1	2	3	4	5	6	7	8	9	10	11	12	13	14	15	16
	E	E	B	C	E	A	C	A	C	E	C	C	D	C	B	A
	17	18	19	20	21	22	23	24	25	26	27	28	29	30	31	32
	E	D	E	A	B	D	E	C	E	E	A	C	C	B	A	C
	33	34	35	36	37	38	39	40	41	42	43	44	45	46	47	48
	E	B	B	B	D	C	C	C	E	E	D	D	E	C	E	D
	49	50	51	52	53	54	55	56	57	58	59	60	61	62	63	64
	C	E	D	A	A	D	A	C	C	B	A	D	A	C	A	A
65	66	67	68	69	70	71	72	73	74	75	76	77	78	79	80	
E	D	B	B	D	E	E	B	C	C	B	A	E	B	B	D	

CEVAP ANAHTARLARI / ANSWER KEYS

Deneme 9	1	2	3	4	5	6	7	8	9	10	11	12	13	14	15	16
	D	C	B	E	E	D	C	B	A	B	C	C	E	B	B	B
	17	18	19	20	21	22	23	24	25	26	27	28	29	30	31	32
	C	A	D	B	A	D	B	E	E	C	E	A	A	C	C	C
	33	34	35	36	37	38	39	40	41	42	43	44	45	46	47	48
	A	C	E	E	E	C	A	D	B	D	D	D	A	E	D	B
	49	50	51	52	53	54	55	56	57	58	59	60	61	62	63	64
	B	A	C	D	D	A	A	A	E	E	B	B	C	D	E	C
	65	66	67	68	69	70	71	72	73	74	75	76	77	78	79	80
E	E	C	A	B	A	B	D	E	D	B	C	B	C	D	D	

Deneme 10	1	2	3	4	5	6	7	8	9	10	11	12	13	14	15	16
	B	C	E	C	C	A	A	B	C	E	D	C	B	E	B	A
	17	18	19	20	21	22	23	24	25	26	27	28	29	30	31	32
	E	D	D	A	A	C	D	E	D	E	C	C	C	E	A	C
	33	34	35	36	37	38	39	40	41	42	43	44	45	46	47	48
	C	D	A	E	A	A	E	C	E	A	C	B	D	A	C	B
	49	50	51	52	53	54	55	56	57	58	59	60	61	62	63	64
	A	A	E	D	C	C	B	A	D	B	C	B	D	B	E	C
	65	66	67	68	69	70	71	72	73	74	75	76	77	78	79	80
A	D	E	D	C	C	B	A	B	E	B	E	C	C	E	D	

Deneme 11	1	2	3	4	5	6	7	8	9	10	11	12	13	14	15	16
	E	C	C	D	B	A	C	A	A	E	E	D	A	C	B	D
	17	18	19	20	21	22	23	24	25	26	27	28	29	30	31	32
	C	E	B	C	A	B	B	B	D	B	A	E	C	D	E	D
	33	34	35	36	37	38	39	40	41	42	43	44	45	46	47	48
	B	A	C	D	A	B	A	E	A	A	D	E	E	D	E	B
	49	50	51	52	53	54	55	56	57	58	59	60	61	62	63	64
	A	A	C	B	D	C	D	B	C	C	D	E	E	A	D	A
	65	66	67	68	69	70	71	72	73	74	75	76	77	78	79	80
D	B	C	A	B	C	E	A	D	D	B	C	D	B	E	E	

Deneme 12	1	2	3	4	5	6	7	8	9	10	11	12	13	14	15	16
	E	B	A	D	D	C	E	C	D	D	A	C	D	C	B	A
	17	18	19	20	21	22	23	24	25	26	27	28	29	30	31	32
	D	C	A	C	B	E	C	C	B	B	A	D	C	D	E	C
	33	34	35	36	37	38	39	40	41	42	43	44	45	46	47	48
	A	E	B	B	C	C	A	C	E	C	B	A	D	B	B	C
	49	50	51	52	53	54	55	56	57	58	59	60	61	62	63	64
	A	E	C	B	D	D	C	D	D	B	A	B	E	E	E	E
	65	66	67	68	69	70	71	72	73	74	75	76	77	78	79	80
C	D	A	C	C	E	E	B	D	B	A	C	D	D	C	D	

CEVAP ANAHTARLARI / ANSWER KEYS

Deneme 13	1	2	3	4	5	6	7	8	9	10	11	12	13	14	15	16
	C	A	B	E	E	D	B	B	D	B	B	B	D	C	C	A
	17	18	19	20	21	22	23	24	25	26	27	28	29	30	31	32
	C	D	D	B	B	D	D	E	D	C	D	E	A	D	C	C
	33	34	35	36	37	38	39	40	41	42	43	44	45	46	47	48
	D	C	B	A	B	B	B	D	E	D	E	B	A	D	C	C
	49	50	51	52	53	54	55	56	57	58	59	60	61	62	63	64
	B	E	B	A	D	E	E	D	E	B	C	B	B	D	D	A
65	66	67	68	69	70	71	72	73	74	75	76	77	78	79	80	
B	D	A	C	A	B	E	D	C	D	E	B	B	C	B	B	

Deneme 14	1	2	3	4	5	6	7	8	9	10	11	12	13	14	15	16
	D	A	B	A	A	D	B	A	D	A	E	C	D	E	C	B
	17	18	19	20	21	22	23	24	25	26	27	28	29	30	31	32
	C	D	E	A	D	D	D	C	A	C	D	D	E	A	D	B
	33	34	35	36	37	38	39	40	41	42	43	44	45	46	47	48
	B	B	D	C	C	D	A	B	D	A	A	A	C	E	D	C
	49	50	51	52	53	54	55	56	57	58	59	60	61	62	63	64
	E	A	E	D	C	D	D	D	E	B	B	D	C	D	D	A
	65	66	67	68	69	70	71	72	73	74	75	76	77	78	79	80
	A	E	B	D	E	D	C	E	A	A	C	B	C	C	C	D
	81	82	83	84	85	86	87	88	89	90	91	92	93	94	95	96
	E	D	B	B	D	A	E	B	A	E	C	C	B	B	C	E
97	98	99	100	101	102	103	104	105	106	107	108	109	110	111	112	
A	E	C	D													

Deneme 15	1	2	3	4	5	6	7	8	9	10	11	12	13	14	15	16
	E	E	B	C	A	C	D	C	B	E	A	D	D	B	E	B
	17	18	19	20	21	22	23	24	25	26	27	28	29	30	31	32
	B	B	B	C	E	A	D	B	B	C	D	D	B	C	D	E
	33	34	35	36	37	38	39	40	41	42	43	44	45	46	47	48
	C	C	E	B	D	B	B	E	D	C	D	A	A	A	D	D
	49	50	51	52	53	54	55	56	57	58	59	60	61	62	63	64
	E	D	E	B	B	C	A	B	E	D	E	D	B	D	C	D
	65	66	67	68	69	70	71	72	73	74	75	76	77	78	79	80
	E	D	B	A	C	B	C	A	B	A	C	E	D	E	D	A
	81	82	83	84	85	86	87	88	89	90	91	92	93	94	95	96
	C	B	B	D	B	A	A	B	D	E	D	C	D	B	A	E
97	98	99	100	101	102	103	104	105	106	107	108	109	110	111	112	
C	B	C	C													

YÖS

5

46.

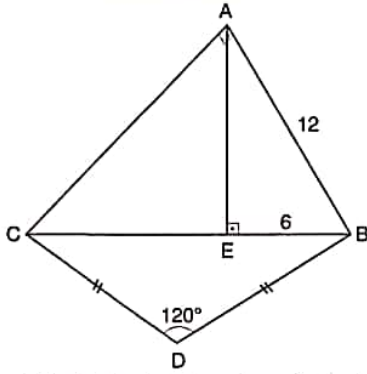

$[CA] \perp [AB]$, $[AE] \perp [BC]$, $|DC| = |BD|$, $|AB| = 12 \text{ br}(u)$,
 $|EB| = 6 \text{ br}(u)$, $m(\widehat{BDC}) = 120^\circ \Rightarrow |BD| = ? \text{ br}(u)$

- A) 6 B) 8 C) $6\sqrt{3}$ D) $8\sqrt{3}$ E) 12

47.

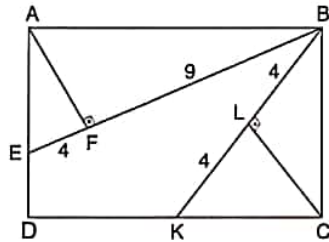

ABCD bir dikdörtgendir. / ABCD is a rectangle.

$[AF] \perp [BE]$, $[BK] \perp [CL]$, $|EFI| = 4 \text{ br}(u)$, $|IFBI| = 9 \text{ br}(u)$,
 $|BLI| = 4 \text{ br}(u)$, $|LKI| = 4 \text{ br}(u)$

$\Rightarrow A(ABCD) = ? \text{ br}^2(u^2)$

- A) $4\sqrt{6}$ B) $3\sqrt{13}$ C) $6\sqrt{2}$
 D) $10\sqrt{26}$ E) $12\sqrt{26}$

48.

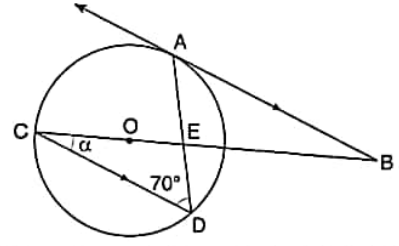

Şekildeki O merkezli çemberde $[BA, A$ noktasında çembere teğettir.

Point O is the center of the circle in the figure and $[BA$ is tangent to the circle at the point A.

$[BA \parallel [CD]$, $m(\widehat{ADC}) = 70^\circ$

$\Rightarrow m(\widehat{BCD}) = \alpha = ?$

- A) 40° B) 45° C) 50° D) 60° E) 70°

49.

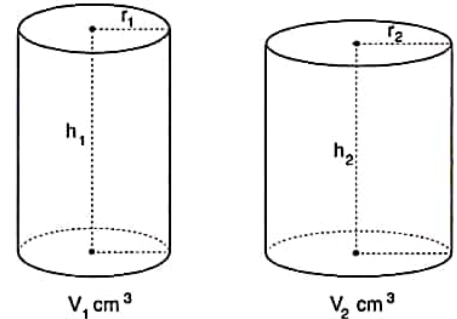

$V_1 = V_2$, $2 \cdot r_1 = r_2 \Rightarrow h_1 / h_2 = ?$

- A) $\frac{1}{2}$ B) $\frac{2}{3}$ C) $\frac{1}{4}$ D) 1 E) 4